

Funktionsbett

BIANCA

DEUTSCH
ENGLISH
NEDERLANDSE
FRANÇAIS
SLOVENSKÝ
ČESKÝ
MAGYAR
HRVATSKI

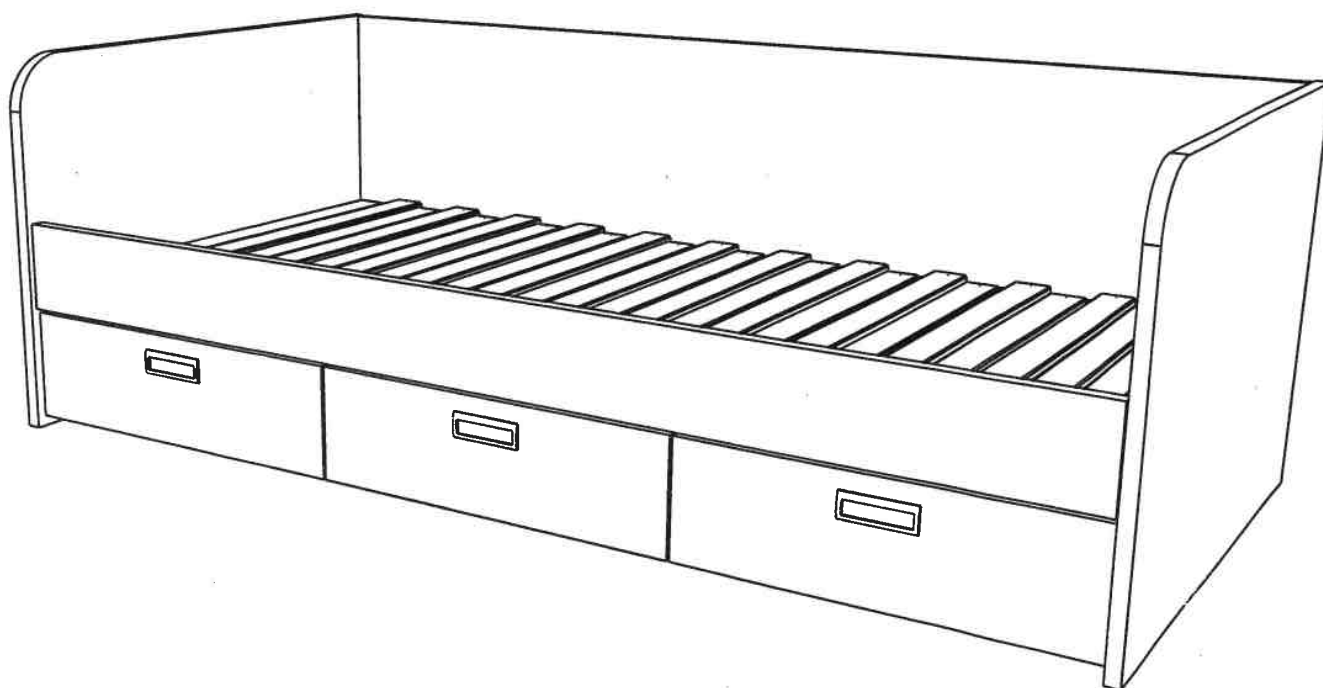

Relita



Relita Dr. Woite GmbH

EB 54841150 / EB 5486085

Stand/version 14.06.2024

Gebrauchsanleitung: Funktionsbett BIANCA

Instruction manual: Multifunction bed BIANCA

Das Bett sollte von 2 Personen aufgebaut werden. (DE)

Wichtig!

Bitte lesen Sie die Gebrauchsanleitung mit den Warn- und Sicherheitshinweisen vor dem Aufbau des Bettes sorgfältig durch und bewahren Sie diese danach auf. Die Gebrauchsanleitung beinhaltet darüberhinaus eine Montageanleitung mit einer Stückliste sowie die notwendigen Werkzeuge für einen sicheren Zusammenbau Ihres Bettes. Wichtig ist das alle Teile und das die benötigten Werkzeuge vollständig vorhanden sind.

Warn- und Sicherheitshinweise:

Die Sicherheitshinweise des Herstellers sind stets zu befolgen. Zum einzelnen sind diese:

1. Achten Sie beim Zusammenbau des Bettes darauf, dass die Verbindungselemente fest angezogen werden. Die Verbindungselemente müssen auch während des Gebrauchs auf Ihren festen Sitz kontrolliert werden.
2. Das Bett darf nicht benutzt werden, wenn ein konstruktives Bauteil beschädigt ist oder fehlt.
3. Folgende Gegenstände dürfen nicht am Bett befestigt oder angehängt werden: Stricke, Schnüre, Kordeln, Gurte, Bänder, etc.. Es besteht Strangulationsgefahr!!
4. Eine ausreichende Raumbelüftung ist notwendig, um die Luftfeuchte niedrig zu halten und Schimmelbildung in und um das Bett zu verhindern.

Pflegehinweis:

Das Bett darf nur mit einem feuchten Lappen gereinigt werden

- ID. Kennung; Funktionsbett **BIANCA**
- Sperrholz

The bed should be put together by 2 people. (EN)

Important!

Please carefully read the instruction manual with the warning and safety instructions before assembling the bed and keep them for future use. The owner's manual also includes assembly instructions with a parts list and the tools required for safe assembly of your bed. It is important to ensure all components and the tools required to be available and complete.

Warning and safety instructions:

Please ensure to generally observe the manufacturer's assembly instructions. In detail, these are:

1. When assembling the bed, make sure that the connecting elements are tightened correctly. The connecting elements must also be monitored for tightness during use.
2. The bed may not be used if any component is missing or broken.
3. The following items may not be attached to or hung on the bed ropes, string, cords, straps, belts, etc... Danger of strangulation!!
4. Please note that the room is to be aerated thoroughly to keep the air humidity low and prevent the formation of mould inside and around the bed.

Care instructions:

The bed should be cleaned only with a damp cloth

- ID. identifier; Multifunction bed **BIANCA**
- Plywood



Relita Dr. Woite GmbH

EB 54841150 / EB 5486085

versie/version 14.06.2024

Gebruiksaanwijzing: Multifunctioneel bed BIANCA

Mode d'emploi du lit multifonction BIANCA

Het bed moet door twee personen opgebouwd worden

(NL)

Belangrijk!

Lees alstublieft zorgvuldig de gebruiksaanwijzing met de waarschuwings- en veiligheidsaanwijzingen voor de opbouw van het bed en bewaar deze daarna.

De gebruiksaanwijzing bevat bovendien een montagehandleiding met een onderdelenlijst alsook de noodzakelijke werktuigen voor een veilige assemblage van uw bed. Belangrijk is dat alle delen en het noodzakelijke gereedschap volledig beschikbaar zijn.

Waarschuwings- en veiligheidsaanwijzingen:

De montage-instructies van de producent moeten altijd nauwgezet opgevolgd worden. Deze zijn:

1. Let er bij de assemblage van het bed op, dat de verbindingselementen stevig aangezet worden. De verbindingselementen moeten ook gedurende het gebruik op hun stevigheid gecontroleerd worden.
2. Het bed mag niet gebruikt worden als een of ander bouwdeel ontbreekt of gebroken is.
3. Volgende voorwerpen mogen niet aan het bed bevestigd of opgehangen worden: strikken, snoeren, koorden, gordels, banden, enzovoort. Er is wurgingsgevaar!!
4. Voldoende kamerverluchting is noodzakelijk om de luchtvochtigheid laag te houden en schimmelvorming in en om het bed te voorkomen

Onderhoudstip:

Het bed mag alleen met een vochtige doek gereinigd worden

- ID-code; **Multifunctioneel bed BIANCA**
- Multiplex

Le lit doit être monté de la part de deux personnes

(FR)

Important !

Avant de commencer à monter le lit, veuillez lire attentivement cette instruction d'utilisation qui contient des instructions d'avertissements et de sécurité. Gardez-la pour l'utiliser plus tard au cas de besoin.

Instructions d'avertissements et de sécurité :

Veuillez obligatoirement respecter les instructions données de la part de producteur. Dans les instructions il y en a des détails donnés ci-dessous :

1. Au cours de de montage du lit, assurez-vous que les éléments d'attachement sont bien fixes. La fixation des éléments d'attachements doit être surveiller même au cours de son utilisation
2. Le lit ne pourrait pas être utilisé au cas où il manque des pièces ou il y en a des pièces cassées.
3. Les objets suivants ne doivent pas être accrochés au lit : ex. Cordes, fils, câbles, lacets, ceintures etc. Danger d'étouffement !!
4. Veuillez retenir que l'espace doit être complètement aéré en fonction de maintenir le bas pourcentage de l'humidité et d'empêcher la moisissure à l'intérieur et autour du lit.

Instructions de maintenance :

La maintenance du lit doit être faite avec des chiffons humides

- ID indicateur ; **lit multifonction BIANCA**
- Contre-plaqué



Relita Dr. Woite GmbH

EB 54841150 / EB 5486085

verzia / verze 14.06.2024

Návod na použitie: **BIANCA Multifunkčná posteľ**

Návod k použití: **BIANCA Multifunkční posteľ**

Posteľ by mala byť skladaná od dvoch ľudí

(SK)

Dôležité!

Pozorne si prečítajte návod na použitie, ktorý obsahuje výstražné a bezpečnostné pokyny, než začnete robiť posteľ. Uložte ho pre budúce použitie.

Pokyny pre varovanie a bezpečnosť: Postupujte podľa pokynov výrobcu. Podrobne zahŕňajú:

1. Pri zostavovaní posteli, skontrolujte, či sú spojovacie prvky bezpečne pripevnené. Tiež, počas používania sa musí kontrolovať upevnenie upevňovacích prvkov.

2. Posteľ sa nesmie používať, ak jedna z častí chýba alebo je rozbitá.

3. Nasledujúce predmety by sa nemali pripevňovať ani zavesiť na posteli: laná, drôty, káble, remene, pásy atď. Hrozí nebezpečenstvo utopenia!!

4. Upozorňujeme, že miestnosť by mala byť úplne vetraná aby sa udržala nízka úroveň vlhkosti vzduchu, čo by zabránilo tvorbe plesní vo vnútri, a okolo postele.

Pokyny na údržbu:

Posteľ by mala byť udržiavaná iba navlhčenou tkaninou

- ID identifikátor, **BIANCA Multifunkčná posteľ**

- Preglejka

Lůžko by se mělo skládat dva člověka

(CZ)

Důležité!

Přečtěte si pozorně návod k použití který také zahrňuje výstražné a bezpečnostní pokyny, než začnete skládat lůžko. Uložte jej a pro budoucí použití.

Upozornění a bezpečnostní pokyny:

Prosíme, postupujte podle pokynů výrobce. Mezi ně patří zejména:

1. Při sestavování lůžka se ujistěte, že jsou spojovací prvky správně připevněny. Rovněž pevnost spojovacích prvků musí být pozorována při použití taky.

2. Lůžko nelze použít v případě, že některá z částí chybí nebo je rozbitá.

3. Na lůžko nesmí být umístěny nebo zavěšeny následující předměty: lana, dráty, kabely, kravaty, popruhy atd. Existuje nebezpečí utopení!!

4. Upozorňujeme, že místnost by měla být plně větrána aby se udržovala nízká úroveň vlhkosti ve vzduchu, což by zabránilo vzniku plísní uvnitř, a kolem postele.

Pokyny pro údržbu:

Lůžko by mělo být udržováno pouze vlhkým hadříkem

-ID identifikátor, **BIANCA Multifunkční posteľ**

-Překližka



Relita Dr. Woite GmbH

EB 54841150 / EB 5486085

változat / verzija 14.06.2024

Használati utasítás: BIANCA többfunkciós ágy

Upute za uporabu: Višenamjenski krevet BIANCA

Az ágy összeszerelési folyamatát célszerű kettő embernek elvégeznie.

(HU)

Fontos!

Kérjük, az ágy összeszerelése előtt szíveskedjen elolvasni a használati útmutatót, melyből tudomást szerezhet az ágy szakszerű összeszerelési folyamatáról és egyben figyelmeztetést a biztonságos használattal kapcsolatban. Őrizze meg a használati útmutatót, mert a jövőben még szüksége lehet rá.

Figyelmeztetési és biztonsági előírások Kérjük, feltétlenül olvassa el a gyártó által megadott használati utasításokat A használati útmutató, többek között, a következőket tartalmazza részletesebben:

1. Az ágy összeszerelési folyamata során, győződjön meg az ágy összekötő részeinek biztonságos és szakszerű összeillesztéséről. Célszerű az összekötő részeket a jövőben is (a használati időtartam alatt), folyamatosan ellenőrizni.
2. Az ágyat nem lehet használni ha annak valamely része hiányos vagy esetleg törött.
3. Az ágyra tilos a következő tárgyakat ráilleszteni kötelek, kábelek, fűzők, szíjak stb. ! Fennáll az esetleges fuldoklási veszély kockázata!
4. Az ágy mögötti esetleges penészképződés és a z ágy körülötti nem kívánatos kellemetlen szagok megelőzése érdekében, kérjük, biztosítsa a helység megfelelő szellőzését, egyidejűleg megfelelő szintű páratartalmát is.

Kezelési útmutatás:

Az ágyat kizárólag nedves ronggyal tisztítjuk

- ID azonosító: **BIANCA** többfunkciós ágy
- Fumér

Krevet trebaju sastavljati dvije osobe.

(HR)

Važno!

Molimo Vas da pažljivo pročitate upute za upotrebu, koje sadrže i upute upozorenja i sigurnosti prije početka sastavljanja kreveta. Čuvajte ih za sljedeću upotrebu.

Upute upozorenja i sigurnosti:

Molimo Vas da obavezno slijedite instrukcije proizvođača. Detaljnije, tu je uključeno:

1. Pri sastavljanju kreveta, budite sigurni da su elementi za povezivanje pravilno pričvršćeni. Isto tako, pričvršćenost elemenata za povezivanje treba nadzirati i prilikom upotrebe.
2. Krevet se ne može koristiti ako nedostaje neki dio ili ako je razbijen.
3. Sljedeći predmeti ne smiju se stavljati ili vješati na krevet konop, žice, kabel, vezice, pojas... Postoji opasnost od davljenja !!
4. Molimo Vas da zapamtite da prostorija treba biti potpuno prozračena radi održavanja niske razine vlage u zraku, čime bi se zaustavilo stvaranje plijesni unutar, i oko kreveta.

Upute za održavanje:

Krevet treba održavati samo vlažnom krpom.

- ID identifikator ; **Višenamjenski krevet BIANCA**
- Iverica

Date 14.06.2024

A x 10	B Ø15x12.5/x 10	C Ø 8 x 35 /x 24	D 4mm Ø7x50 /x 18	E 4mm Ø7x70/x 6	F Ø 4 x 40/x 61	G EURO 6.3x20 /x12	H Ø 4 x 20 /x 20
I glue /x 1	J x 6	K Ø3.5 x 16 /x 34	L /x 2	M CR / x 3	M DL / x 3	M CL / x 3	M DR / x 3
N x 3	O x 2	P Ø 3.5 x 10 /x 4	R x 1				

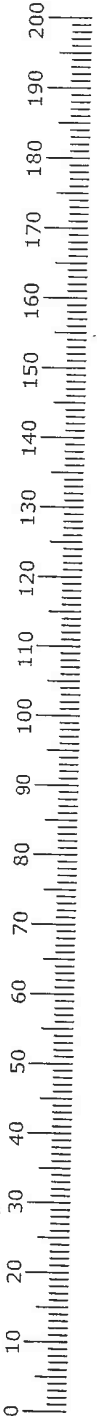
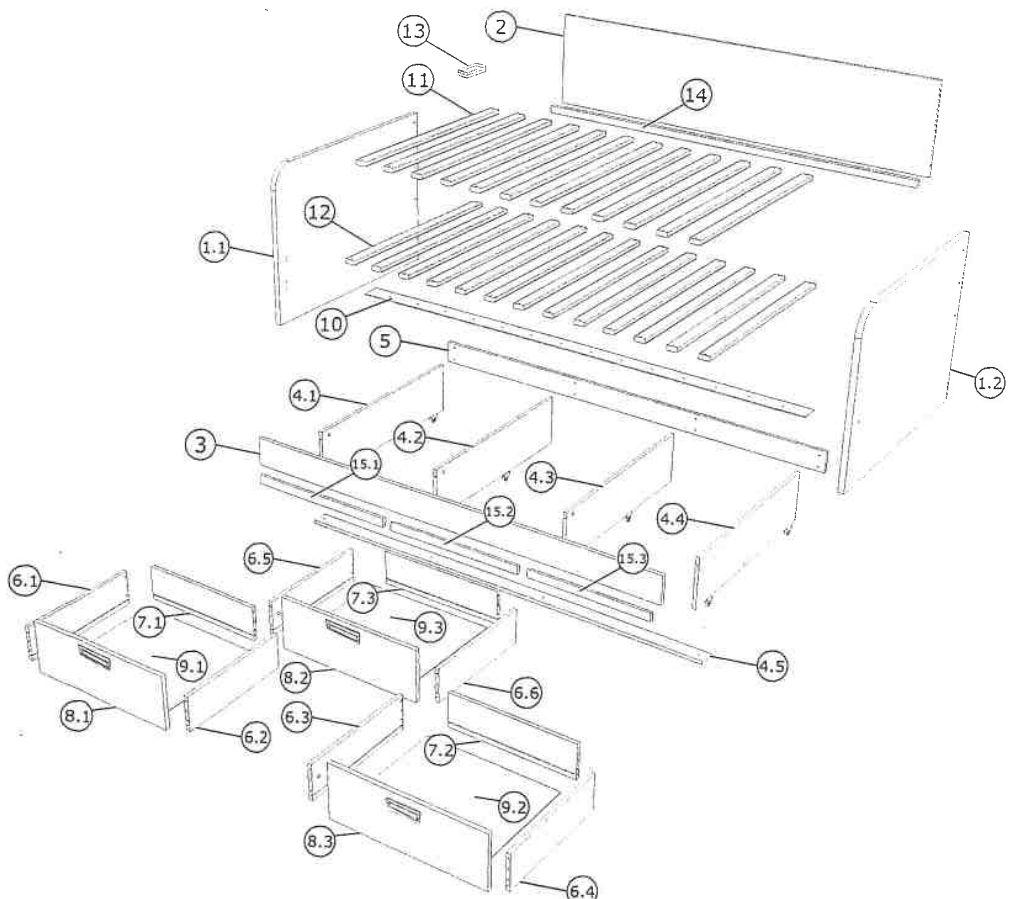

Stückliste / Bill of Materials / Detail visserie

N°	QTY.	Dimensions / mm	Box *
1.1	1	990x695x25	1/4
1.2	1	990x695x25	1/4
2	1	2006x45x18	2/4
3	1	1998x160x25	2/4
4.1	1	884x233x16	2/4
4.2	1	884x233x16	2/4
4.3	1	884x233x16	2/4
4.4	1	884x233x16	2/4
4.5	1	1978x80x16	2/4
5	1	2002x150x16	3/4
6.1	1	500x150x16	3/4
6.2	1	500x150x16	3/4
6.3	1	500x150x16	3/4
6.4	1	500x150x16	3/4
6.5	1	500x150x16	3/4
6.6	1	500x150x16	3/4

N°	QTY.	Dimensions / mm	Box *
7.1	1	580x150x16	3/4
7.2	1	580x150x16	3/4
7.3	1	580x150x16	3/4
8.1	1	663x200x18	2/4
8.2	1	663x200x18	2/4
8.3	1	663x200x18	2/4
9.1	1	595x500x3.2	1/4
9.2	1	595x500x3.2	1/4
9.3	1	595x500x3.2	1/4
10	1	2006x80x8	2/4
11	12	900x67x15	4/4**
12	13	900x67x15	4/4**
13	1	91x50x3	4/4**
14	1	1995x35x25	2/4
15.1	1	634x35x25	2/4
15.2	1	634x35x25	2/4
15.3	1	634x35x25	2/4

* Welches Teil ist in welcher box / Which part is in which box / Répartition des pièces par boîte
 ** Zusätzlicher Satz optional / Additional set optional / Jeu supplémentaire en option

(D) ACHTUNG bei einer Beanstandung !!
 Um eine zügige Beanstandungsabwicklung zu gewährleisten, bitte bei Beschlägen den Buchstaben und die Menge angeben,
 Beispiel: A M6x95
 bei Möbelteilen die Zahl angeben
 Beispiel: 1 1960x160x20

(GB) If you have a COMPLAINT !!
 in order to enable us to deal with any complaints quickly, in the case fittings please state the letter and the quantity,
 Example: A M6x95
 For furniture items please state the number
 Example: 1 1960x160x20

(NL) OPGELET bij een klacht !!
 Om een vlotte klachtenafwerking te waarborgen, bij beslag de letters, het codenumber, en het aai,
 bvb: A M6x95
 bij meubeldelenhet kengetal aangeven
 bvb: 1 1960x160x20

(F) ATTENTION en cas de réclamation !!
 Pour assurer un traitement rapide des réclamations, veuillez indiquer, pour les ferrures, la lettre, le n,
 Exemple: A M6x95
 Pour les parties de meubles indiquer le nombre
 Exemple: 1 1960x160x20

FUNKTIONSBETT BIANCA

1

F ⊕ 23 st.



10Min.

Positioning and securing of the bed side slats

<p>1</p> <p>Put the back panel of the bed on ground facing backside and make sure that there is nothing below the panel</p>	<p>2</p> <p>Put the front panel of the bed on ground facing frontside and make make sure that there is nothing below the panel</p>
<p>3</p> <p>Make sure that front panel of the bed and back side panel of the bed are clean from dust, dirt and oil.</p>	<p>4</p> <p>Make sure that all panels that you need to apply glue to are clean from dust, dirt and oil and then apply glue on them.</p>
<p>5</p> <p>5 Min.</p> <p>Make sure that you apply the glue from right side and wait 5min. for glue to cure.</p>	
<p>6</p> <p>Gently turn over all panels that you apply glue on and place them on right position.</p>	<p>7</p> <p>Gently apply pressure on the surface of the panels and secure them with screws. IMPORTANT: Full cure time of the glue is 12 hours!</p>

FUNKTIONSBETT BIANCA

2	E	4mm	6 st.
	H		8 st.
	O		2 st.
	L		2 st.
	P		4 st.

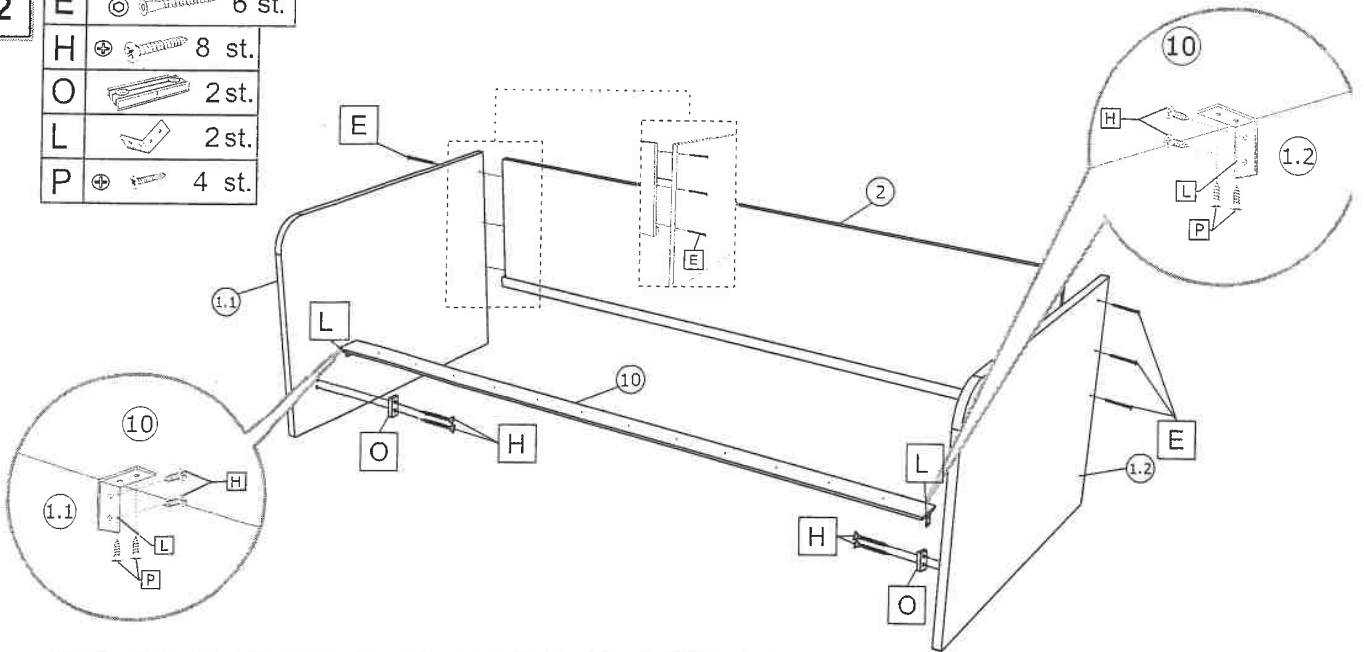

3	G		12 st.
	F		12 st.

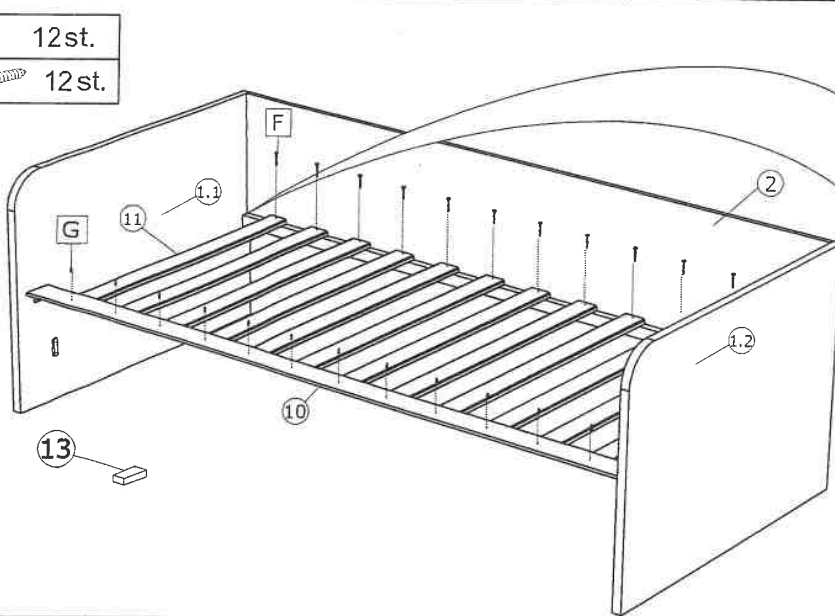

ACHTUNG
Setzen Sie Abstand zu bekommen

IMPORTANT
Put to get distance

AANDACHT
Zet om afstand te krijgen



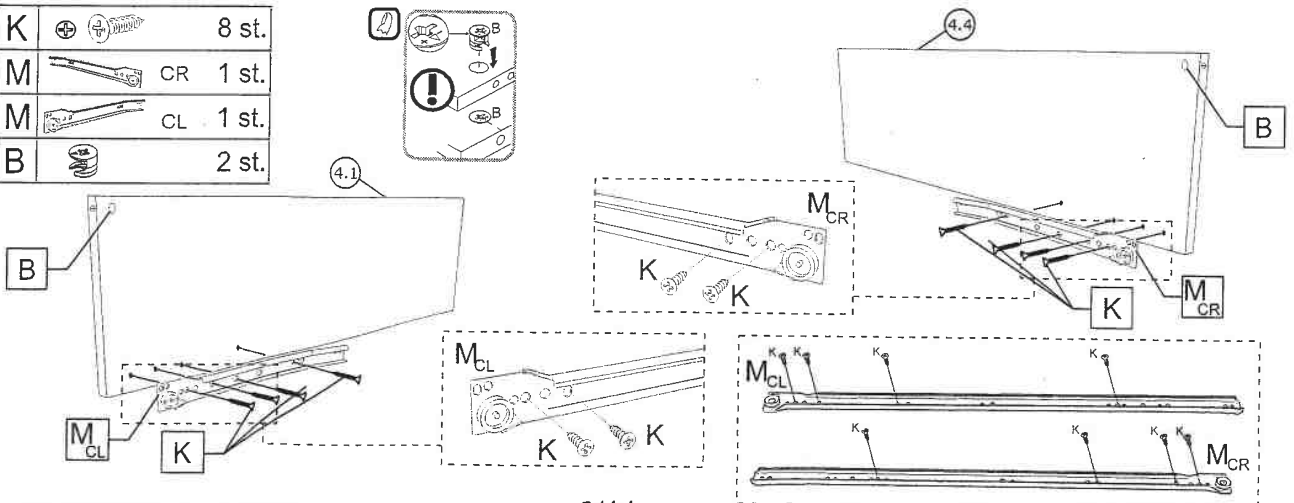

ATTENTION
Mettez pour obtenir la distance

4	K		8 st.
	M	CR	1 st.
	M	CL	1 st.
	B		2 st.





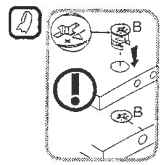
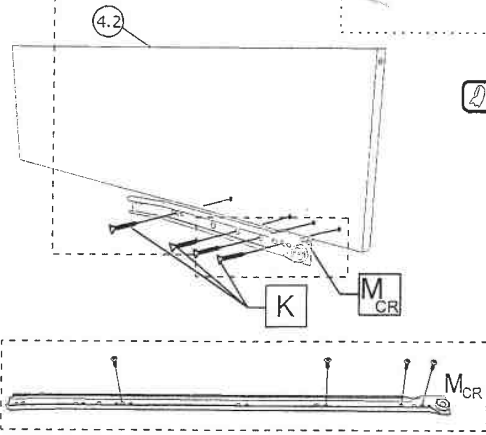
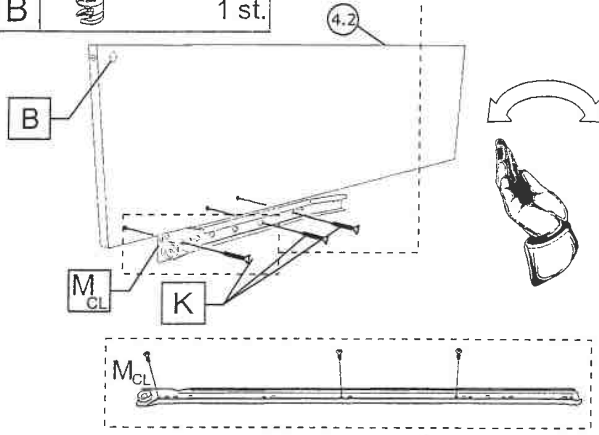
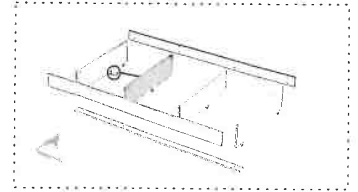
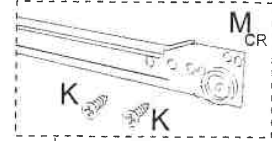
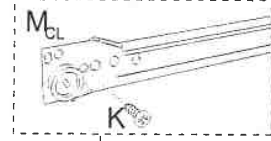

FUNKTIONSBETT BIANCA

5

K		7 st.
M		CR 1 st.
M		CL 1 st.
B		1 st.



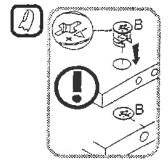
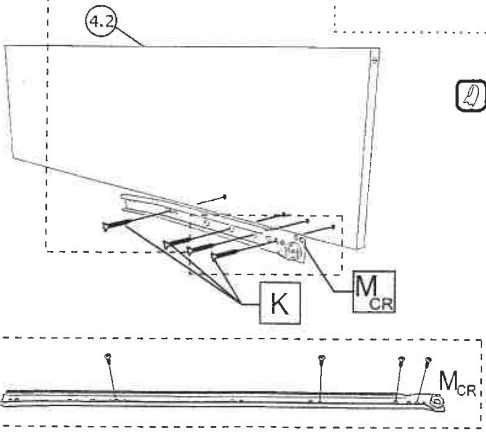
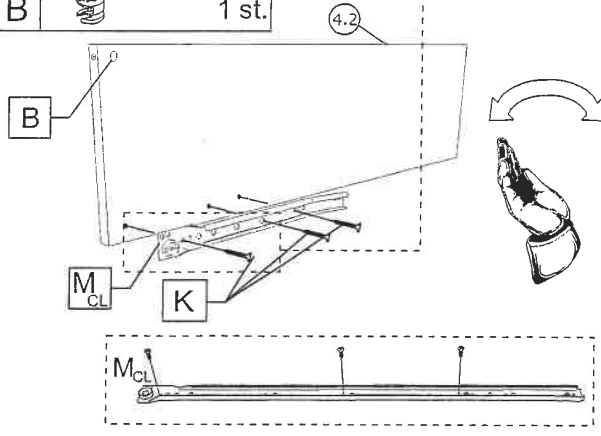
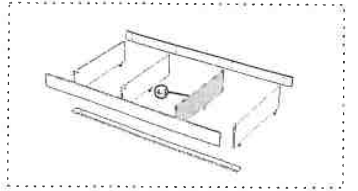
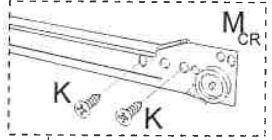
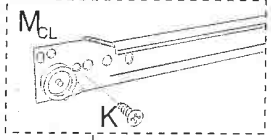

6

K		7 st.
M		CR 1 st.
M		CL 1 st.
B		1 st.



7

H		12 st.
J		6 st.

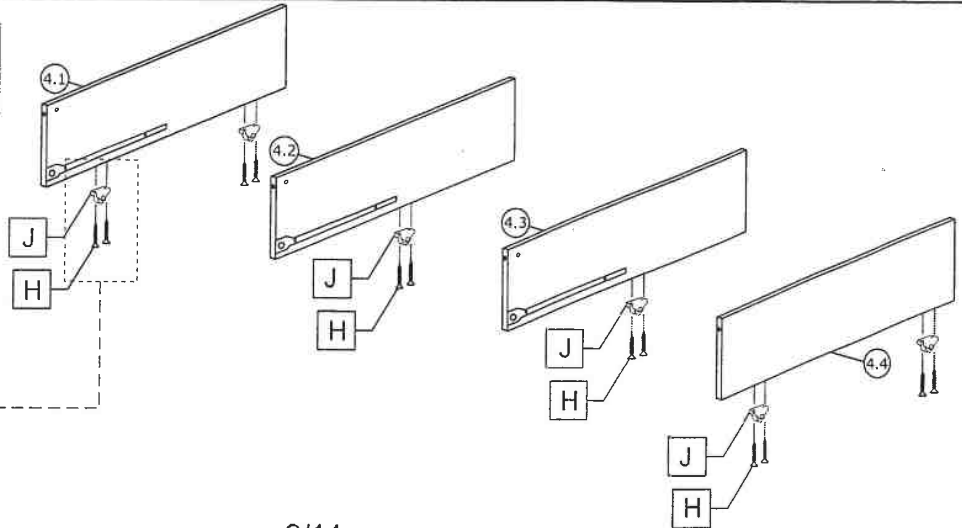
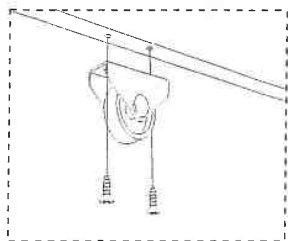

FUNKTIONSBETT BIANCA

8

D  12 st.

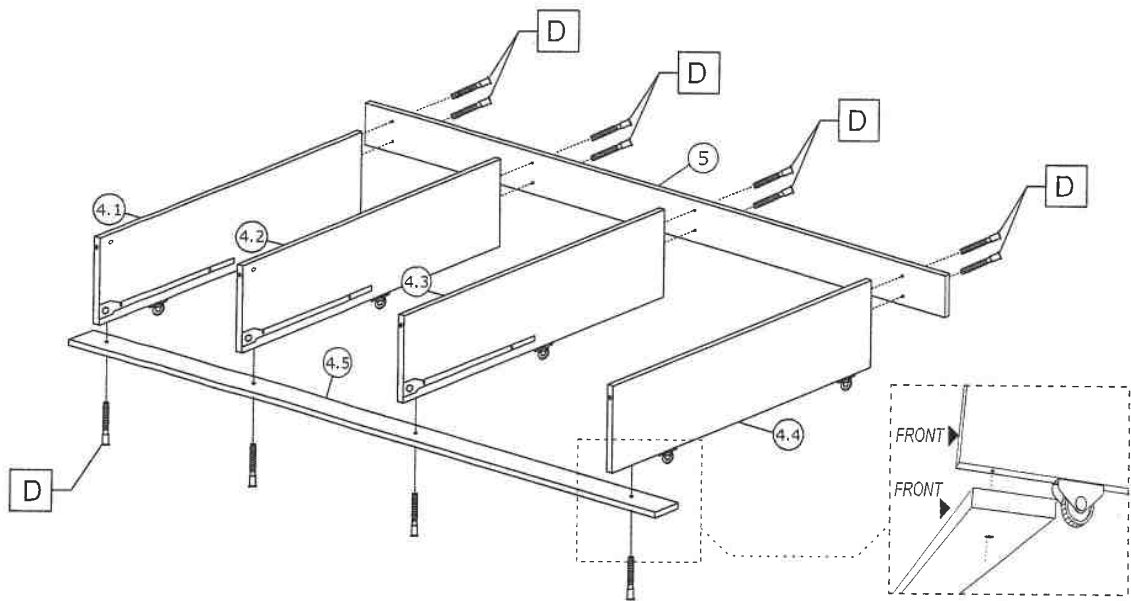

9

A  4 st.

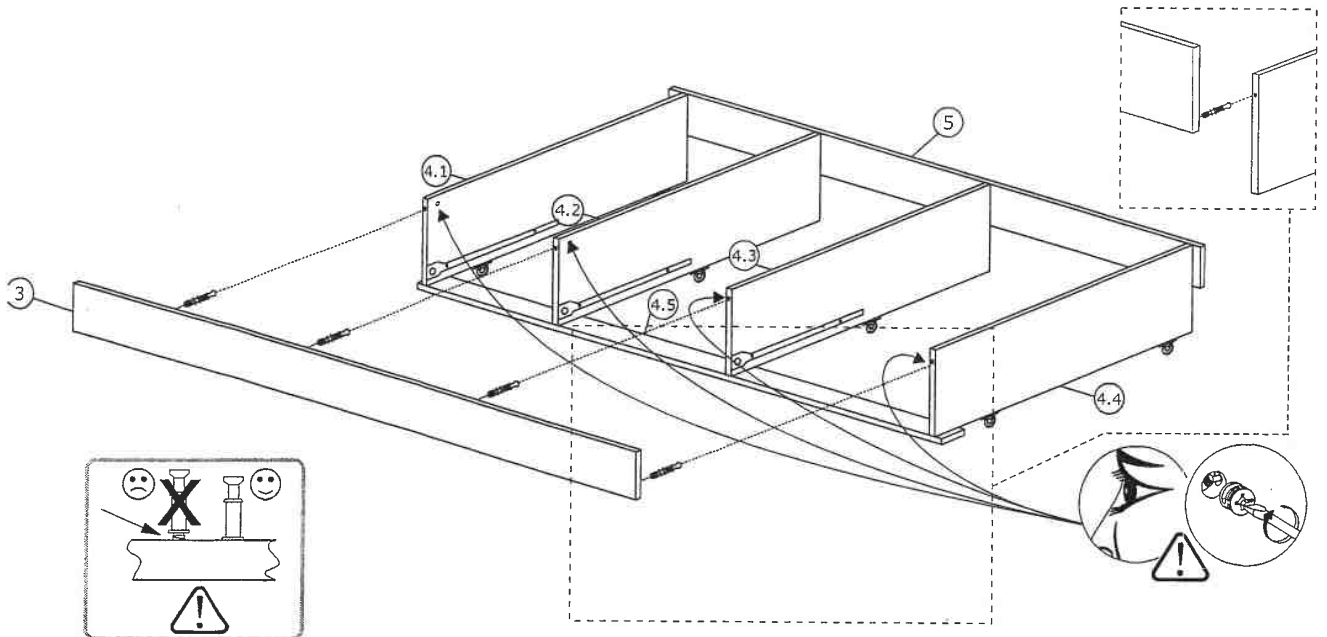

FUNKTIONSBETT BIANCA

10

F  26 st. F

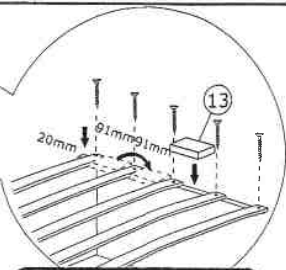
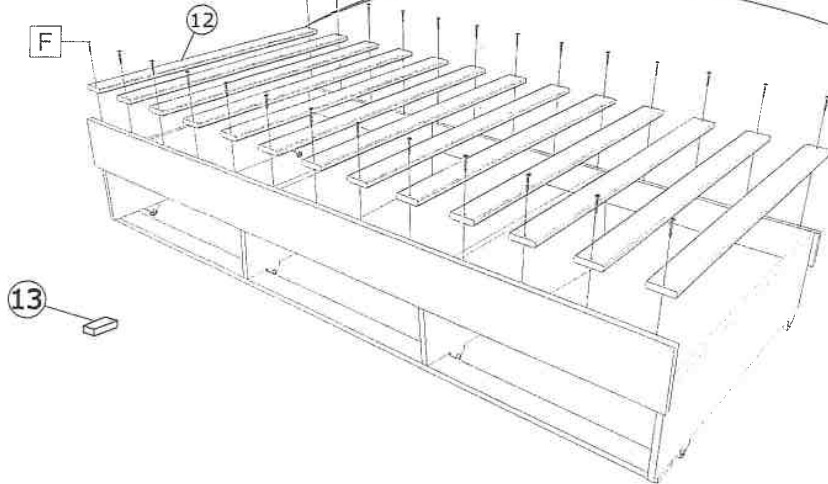





ACHTUNG
13 einsetzen um den Abstand zu erhalten

IMPORTANT
Put to get distance

AANDACHT
Zet om afstand te krijgen



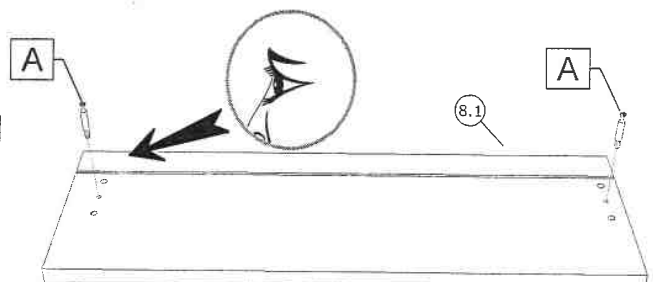
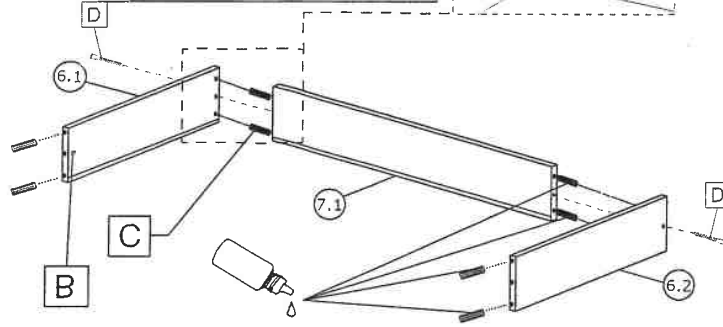
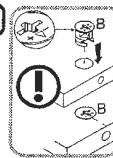
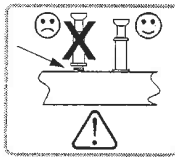
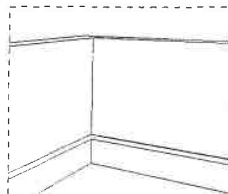

ATTENTION
Mettez pour obtenir la distance

11

A		2 st.
B		2 st.
C		8 st.
D		2 st.



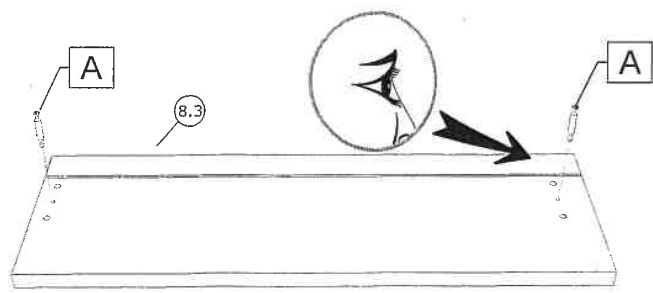
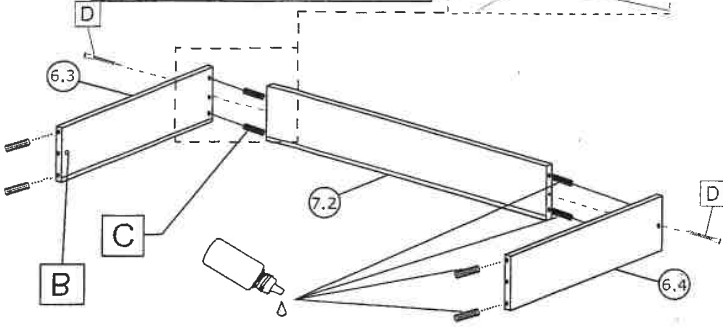
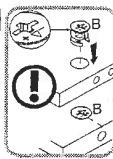
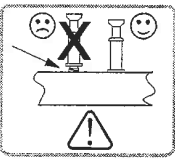
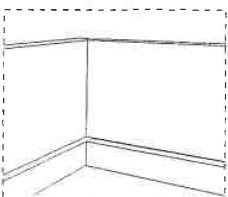

12

A		2 st.
B		2 st.
C		8 st.
D		2 st.



FUNKTIONSBETT BIANCA

13

A		4 st.
B		4 st.
C		8 st.

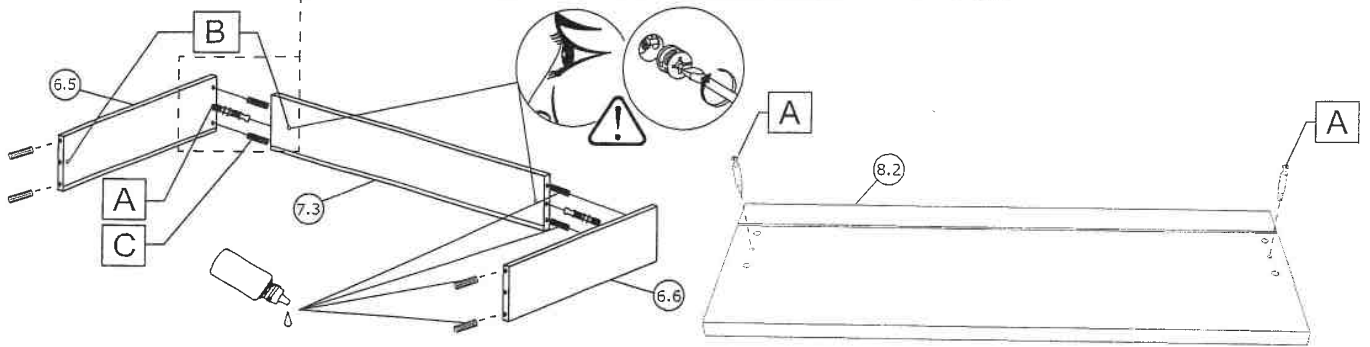
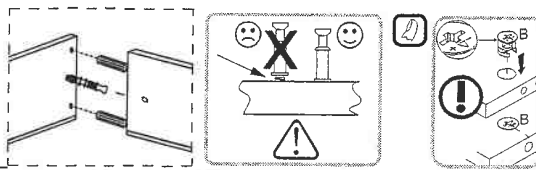

14

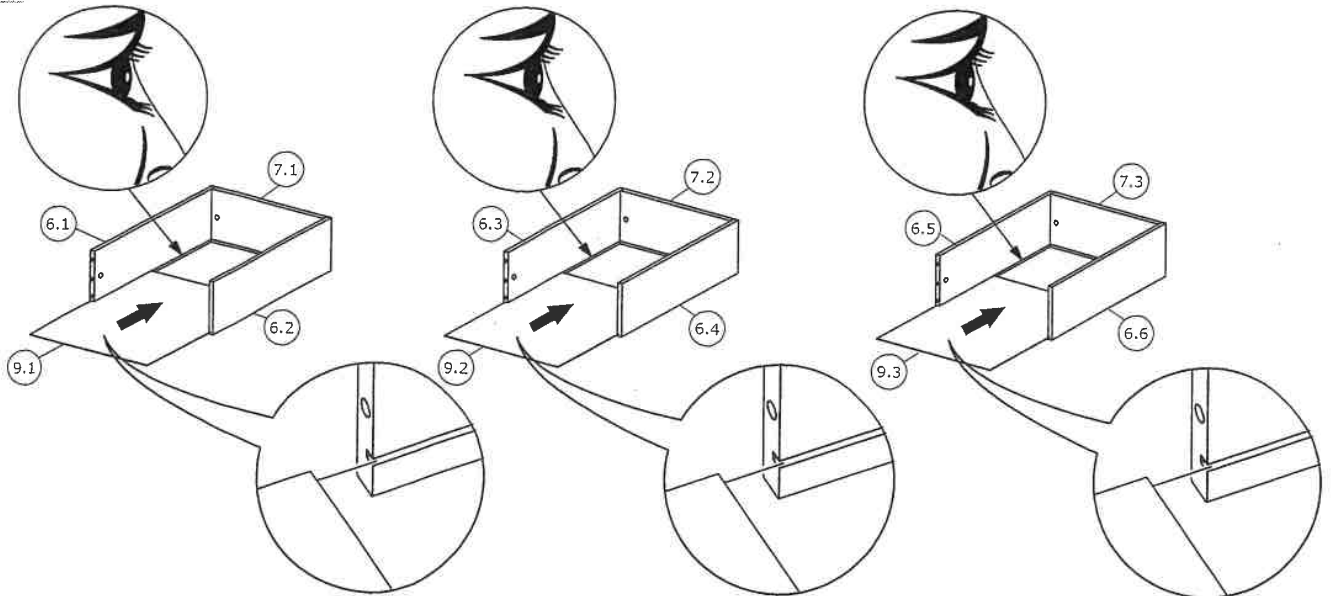

15

N		1 st.
---	---	-------

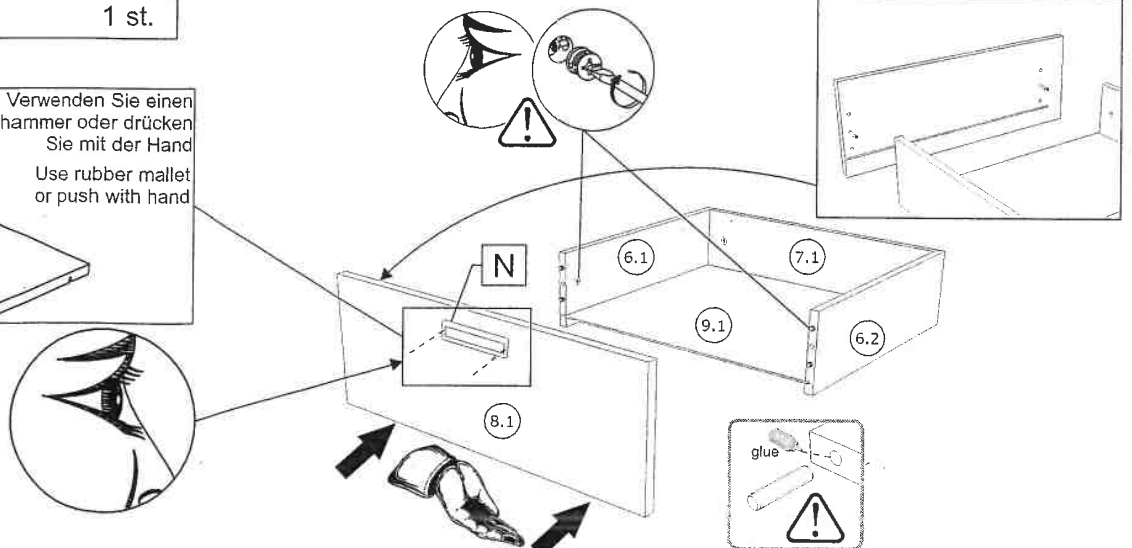
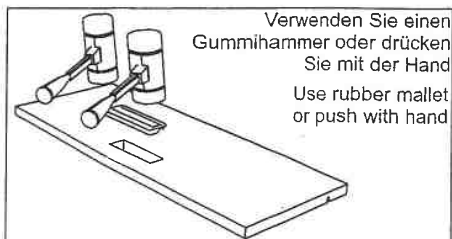

FUNKTIONSBETT BIANCA

16

N  1 st.

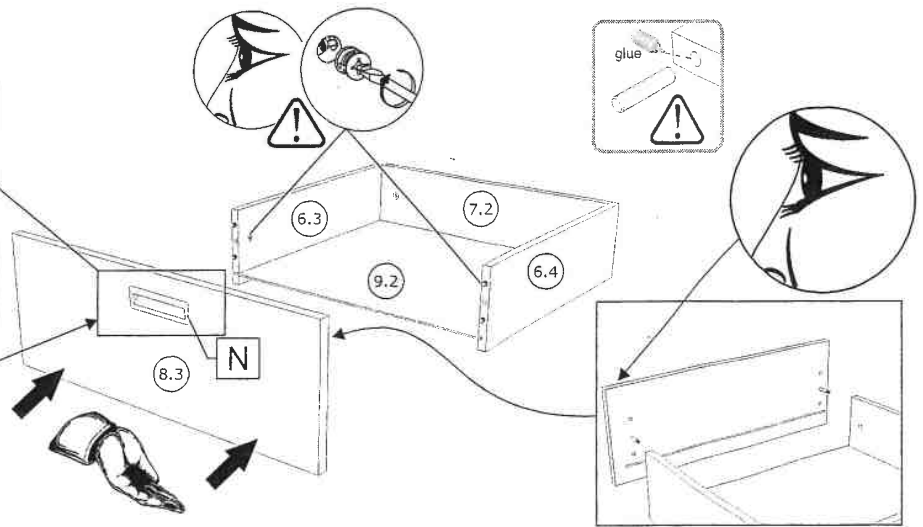
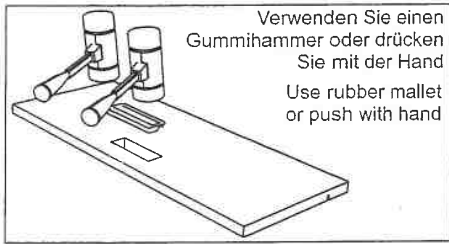

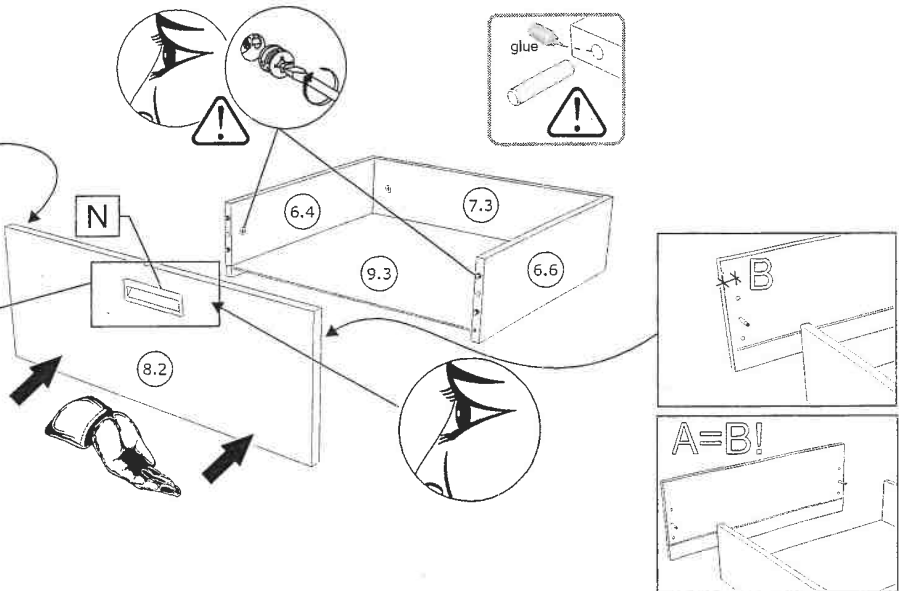
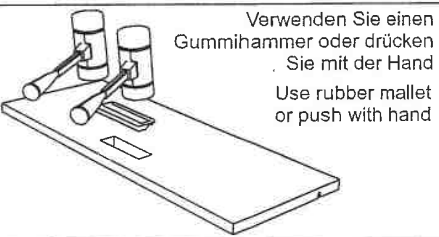
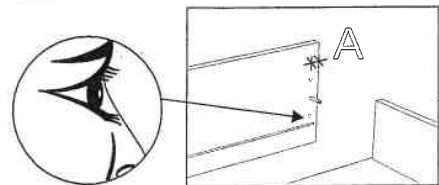

17

N  1 st.



18

K		12 st.
M		DR 3 st.
M		DL 3 st.

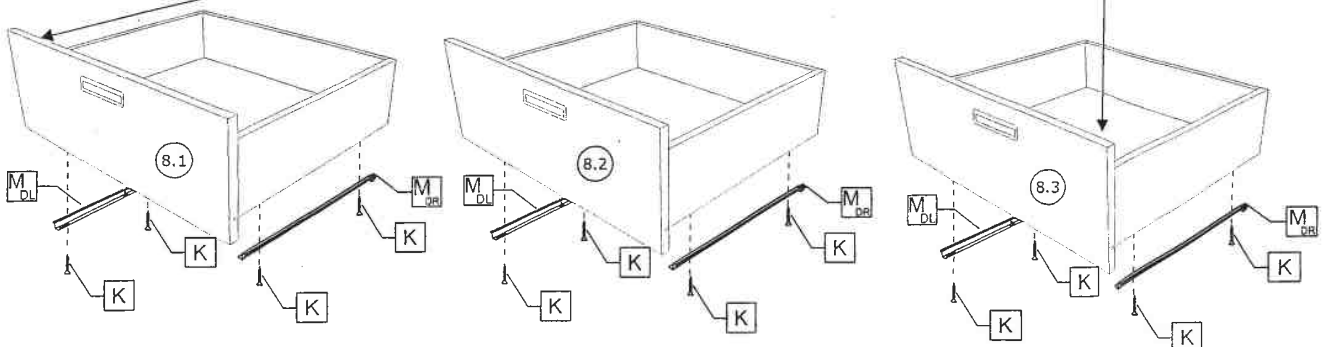
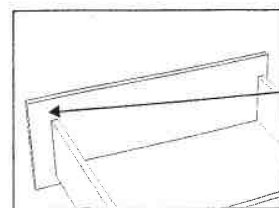
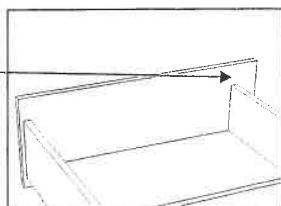

FUNKTIONSBETT BIANCA

20

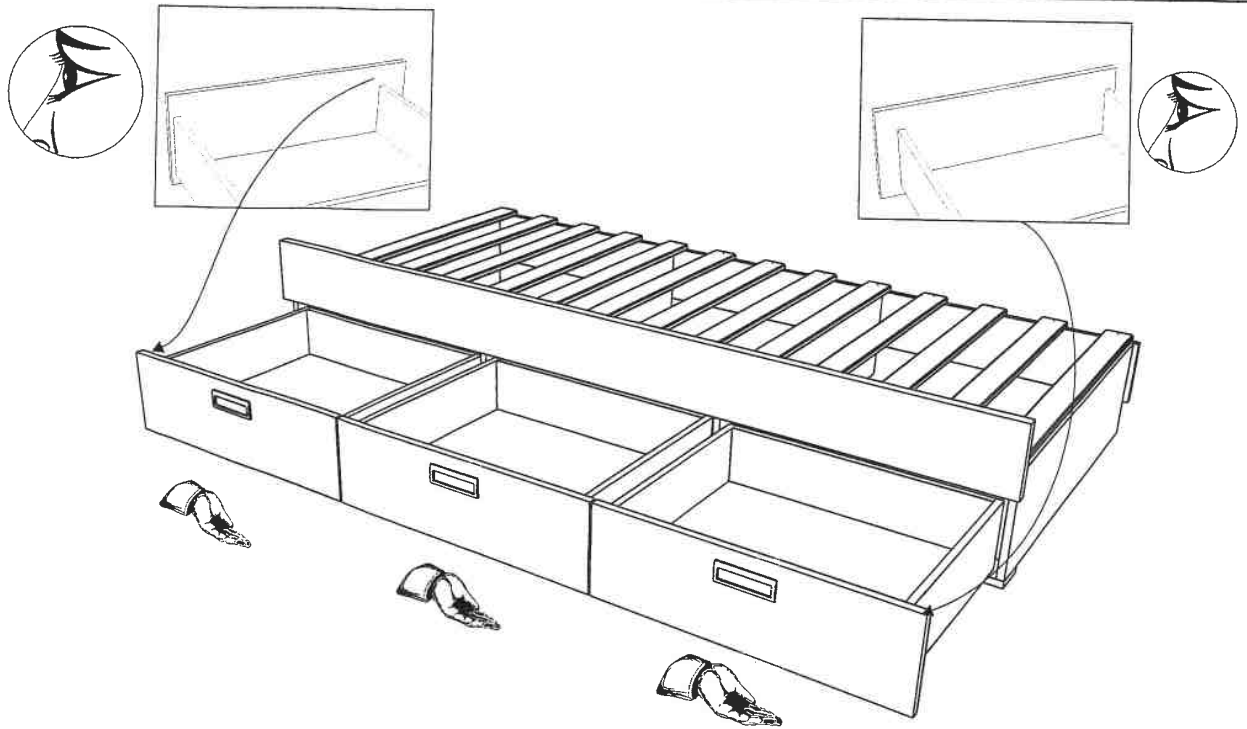

21

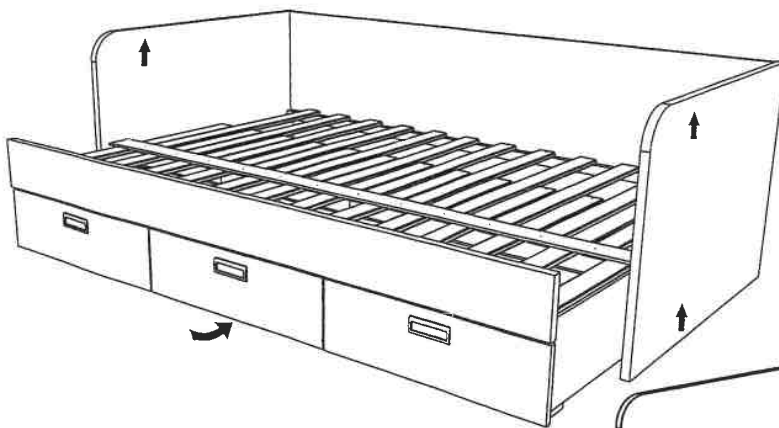

ACHTUNG
Heben Sie zum Einfügen

IMPORTANT
Lift to insert

AANDACHT
Lift in te voegen

ATTENTION
Ascenseur pour insérer

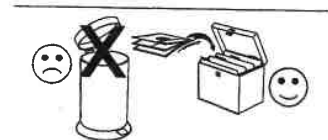
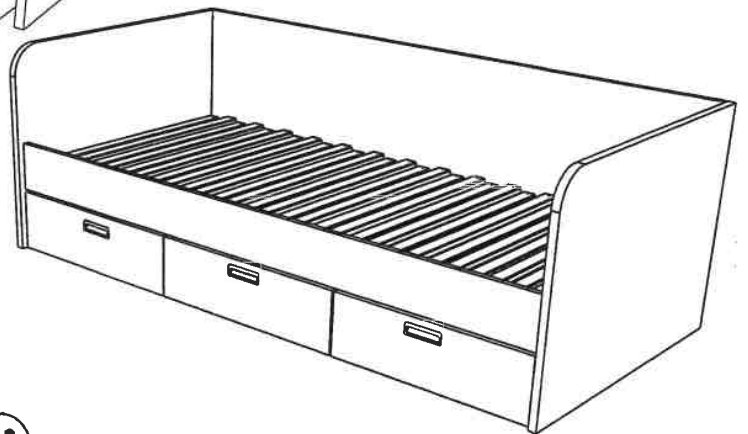

Montageanleitung Funktionsbett **BIANCA**

Mountinginstruction Funktionsbett **BIANCA**

Mounting instructions Multifunction bed **BIANCA**

Instrucciones de montaje para la cama funcional **BIANCA**

Date 14.06.2024

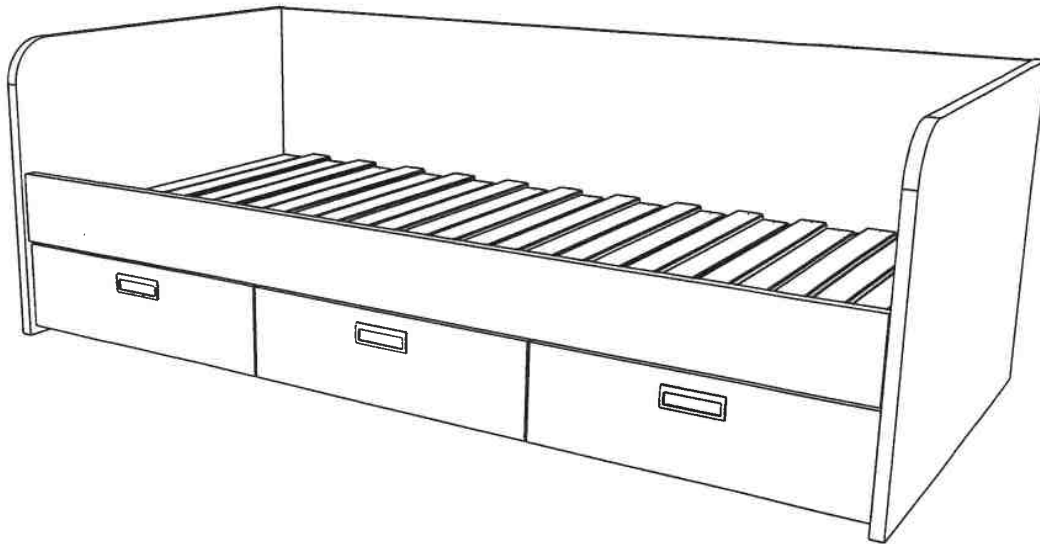

Notwendiger Hinweis:

Important information:

Belangrijke informatie:

Information importante:

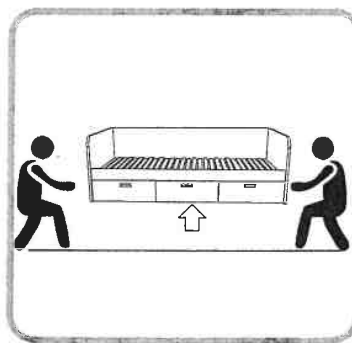

Bett nicht verschieben,
nur angehoben verstellen.

Move not only raises
bed adjusted

Bed niet verschuiven,
men moet het bed opheffen
om te verplaatsen

Ne pas pousser le lit,
il faut le porter pour déplacer

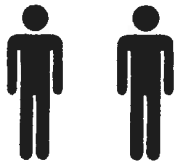

🕒 2:30'

