

- Ⓛ Montageanleitung
- Ⓝ Handleiding voor de montage
- Ⓜ Montaj talimat
- Ⓧ Notice de montage
- Ⓒ Montážní návod
- ⓗ Szerelési útmutató
- ⓖ Assembly Instructions
- Ⓟ Instrukcja montażu
- Ⓡ Инструкция по монтажу
- Ⓣ Istruzioni di montaggio
- Ⓢ Návod na montáž
- Ⓡ Instrucțiuni de montaj
- ⓔ Instrucciones de montaje
- Ⓡ Montaj Talimat

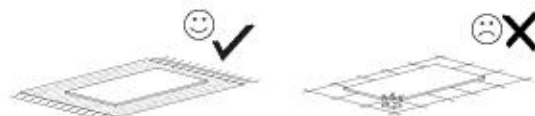

nr	L [mm]	B [mm]	T [mm]	Menge	Coll
1	350	300	16	1	1/1
2	350	300	16	1	1/1
3	968	266	16	1	1/1
4	962	254	16	1	1/1
5	862	100	16	1	1/1
6	962	344	16	1	1/1
7	968	332	16	1	1/1

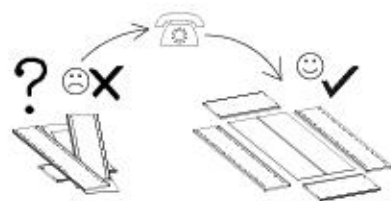
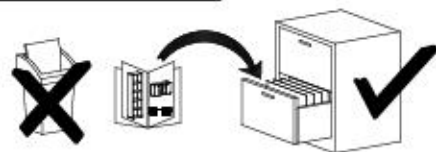
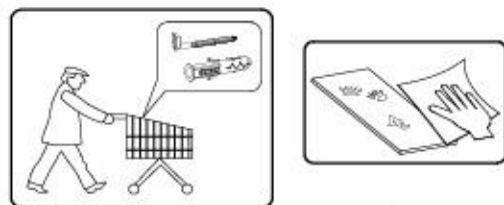
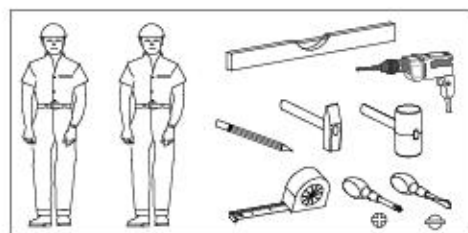
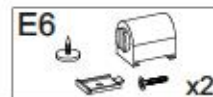
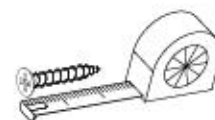
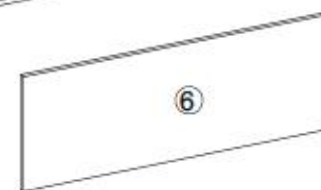
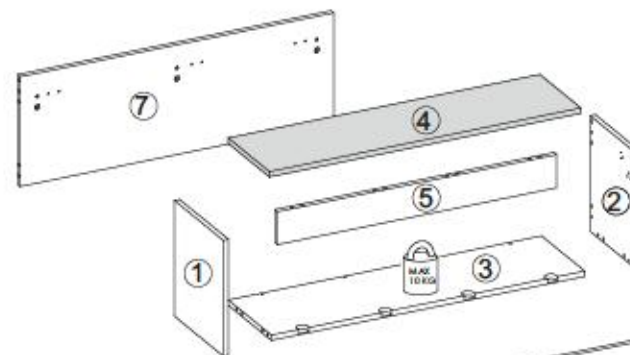

B1 ø8x35 x14	I7 x8	K1 x16	K10 x16	F4 x2
D4 x2	G34 3,5x16 x4	G52 5x11 x6	P10 x3	C6 x2
C16 80N x2	C17 60N x2	C20 x4	I8 x3	Q2 x3

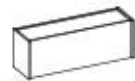

I

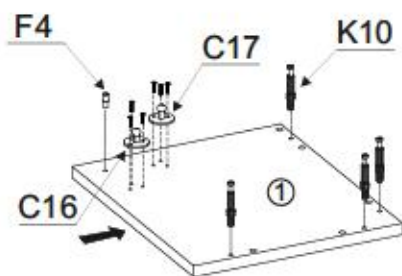

F4



x2

K10



x8

C16



80N x2

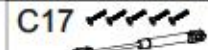

60N x2

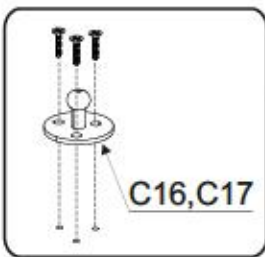
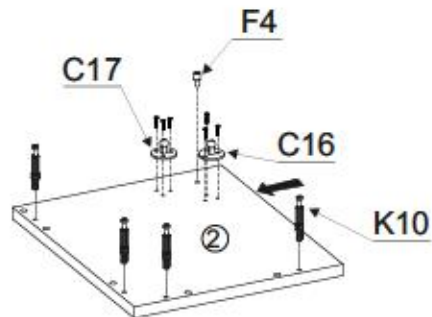

C16,C17

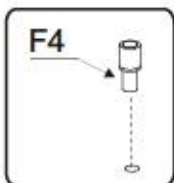

F4

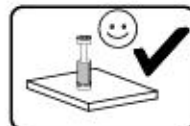

II

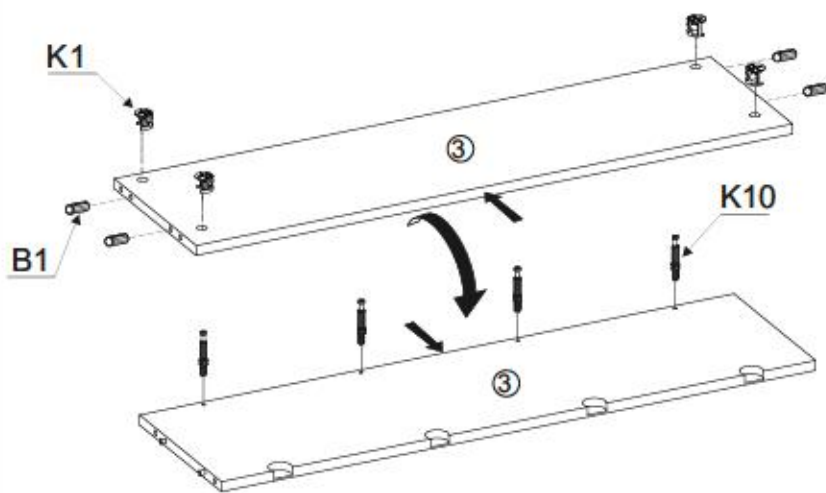

K10



x4

B1



x4

K1



x4

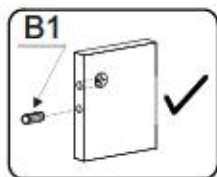

B1

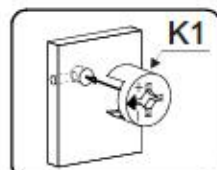

K1

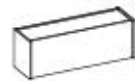

III

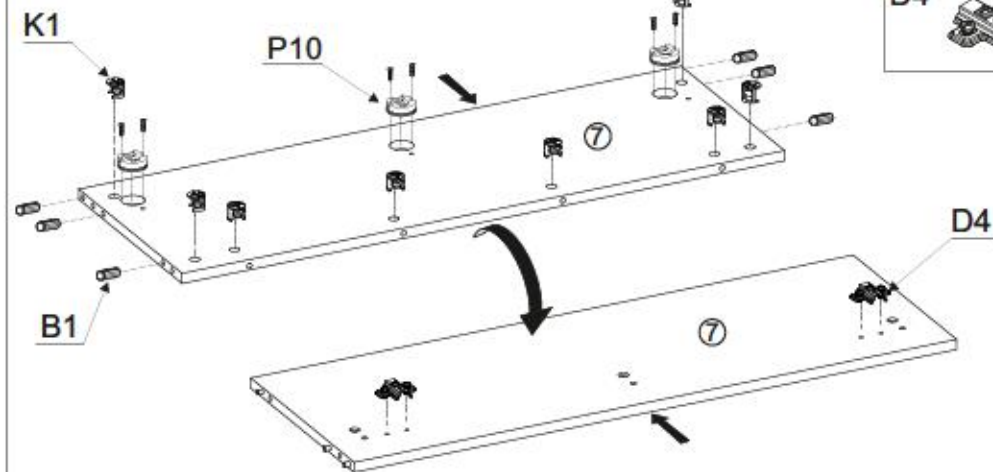

B1



x6

K1



x8

G52



5x11 x6

P10



x3



x2

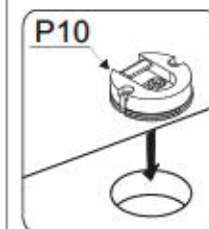

P10

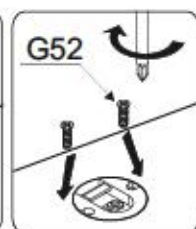

G52

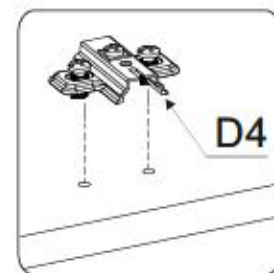
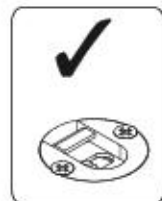

D4

IV

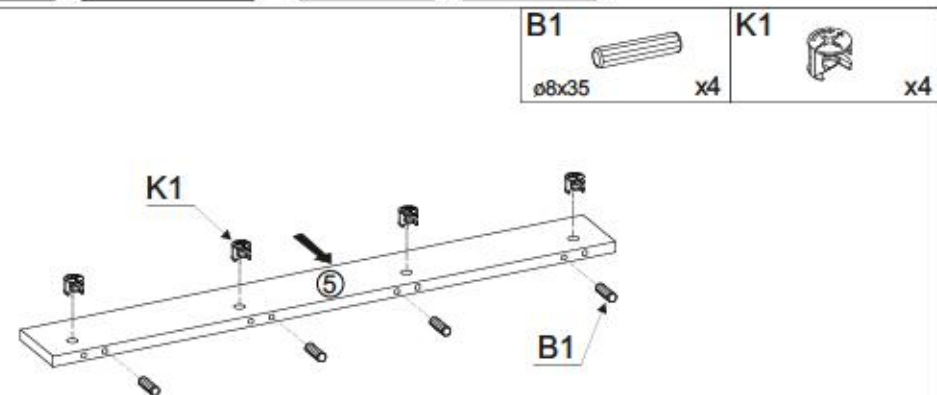

B1



x4

K1



x4

5/13

CITY / GIRON 08



V

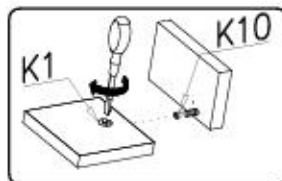
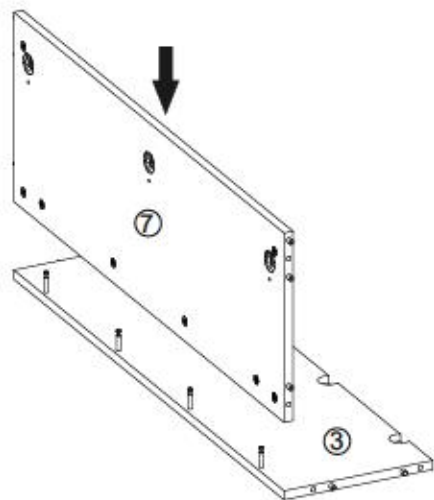

VI

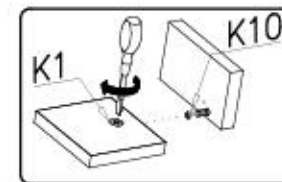
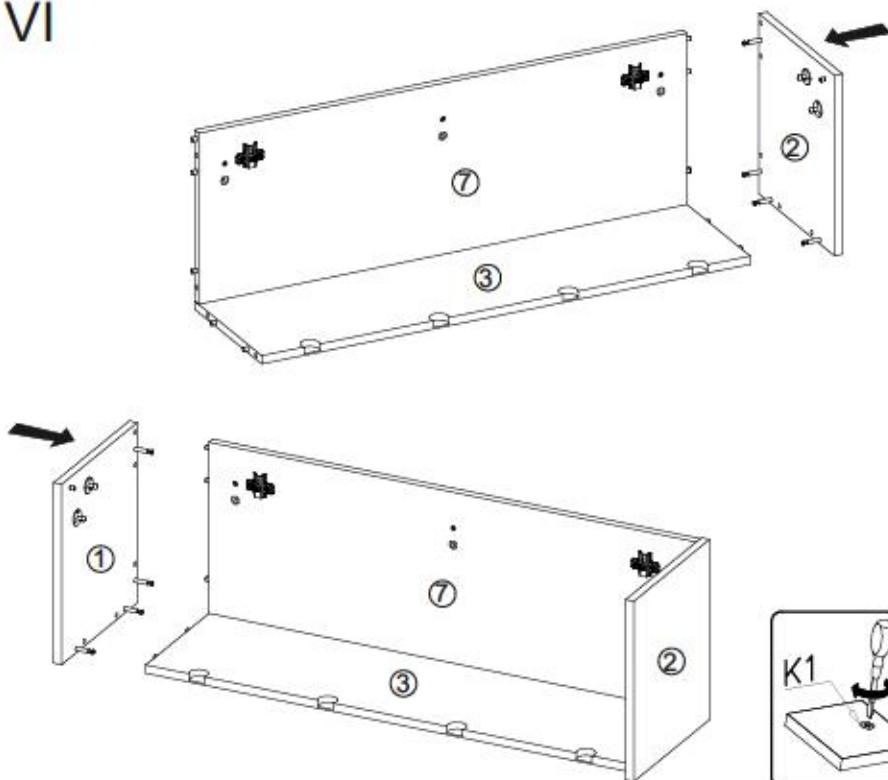

6/13

CITY / GIRON 08

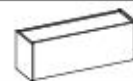

VII

G34
3,5x16 x4

x4

C20 x4



x4

E6 x2



x2

C16 x2



x2

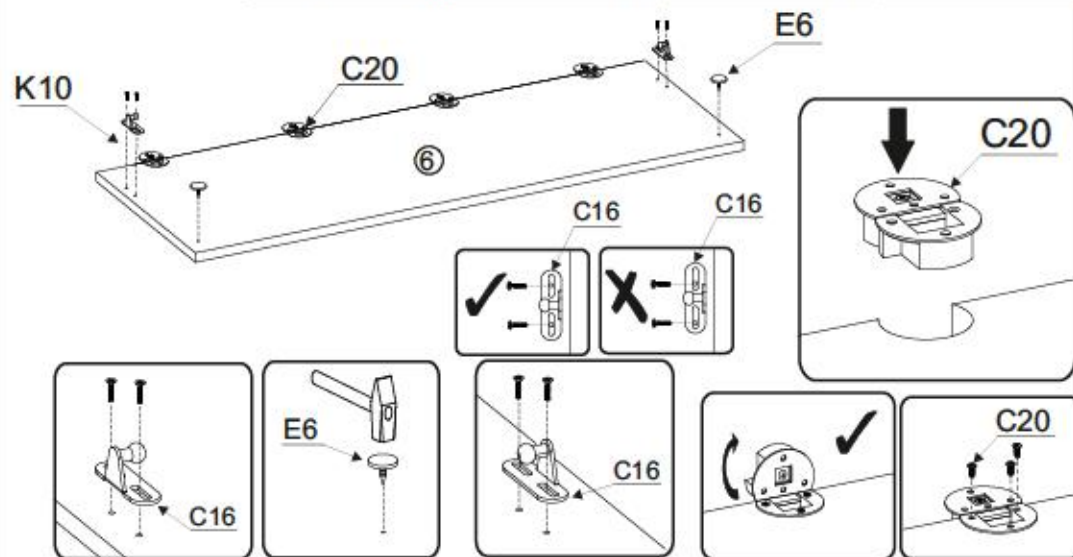

VIII

K10 x4



x4

C6 x2



x2

E6 x2



x2

G34 3,5x16 x4



x4

C17 x2



x2

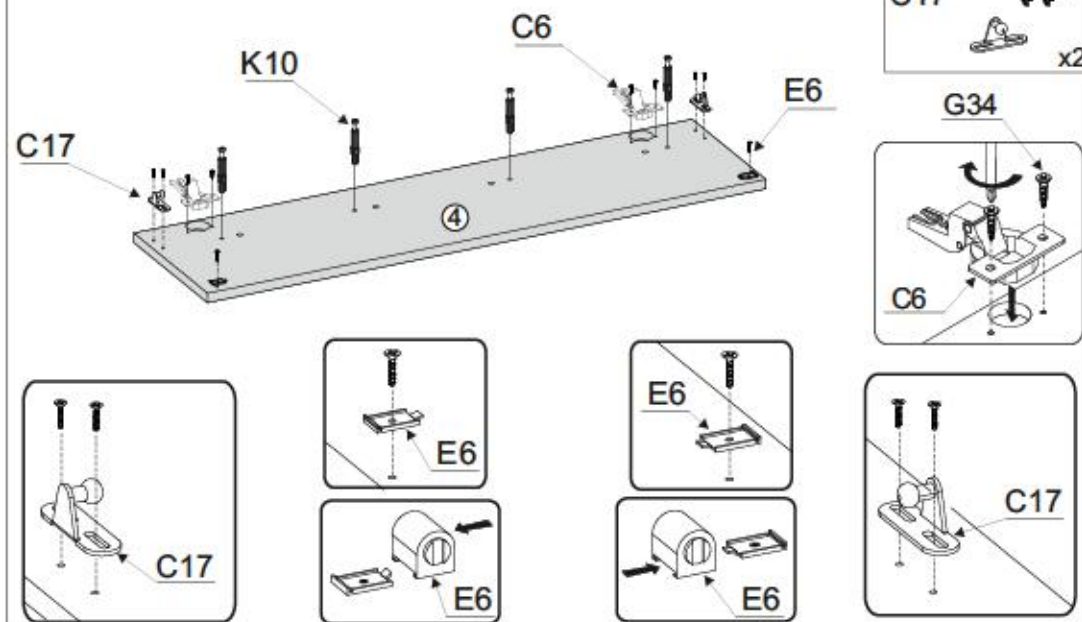

7/13

CITY / GIRON 08



IX

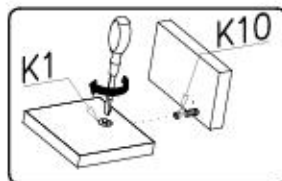
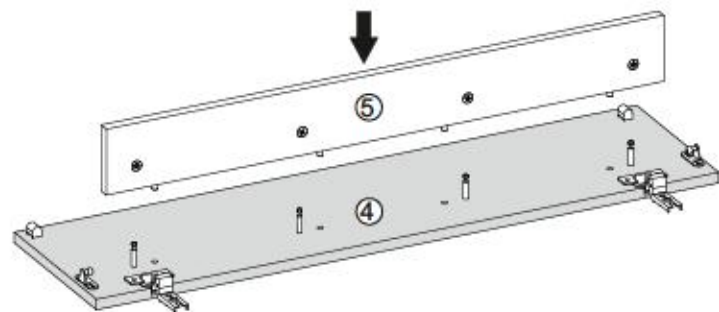

X

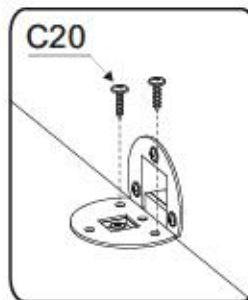
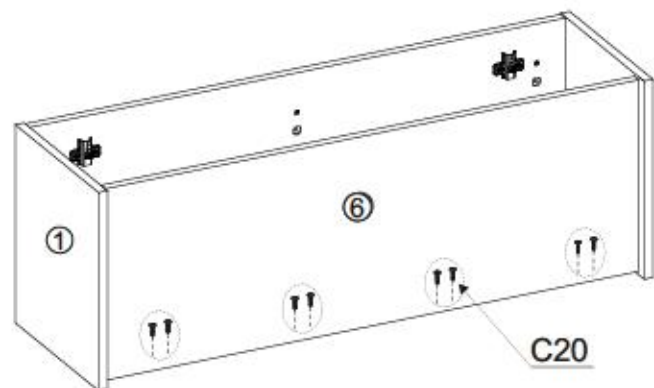
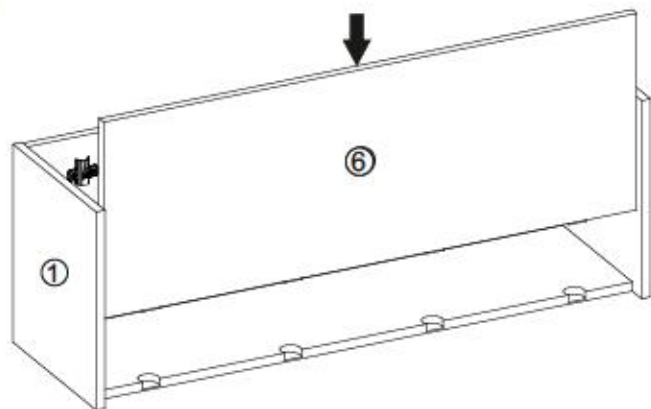

8/13

CITY / GIRON 08



XI

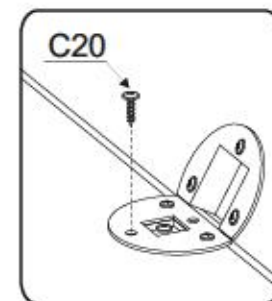
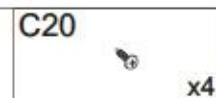
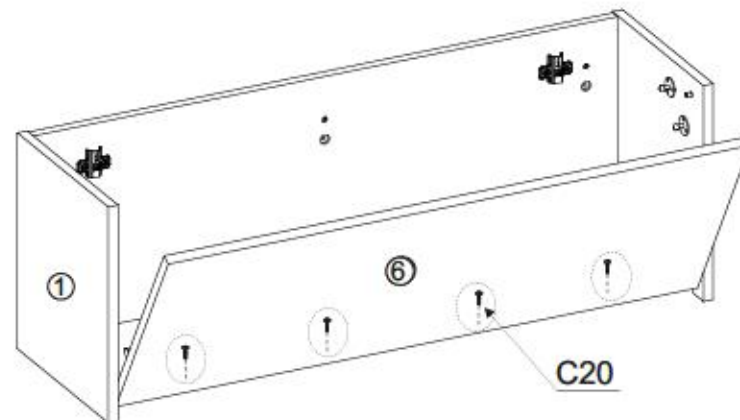

XII

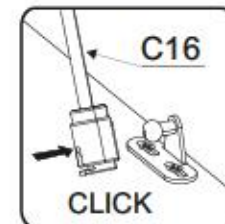
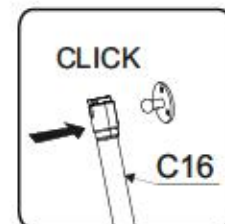
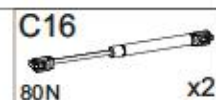
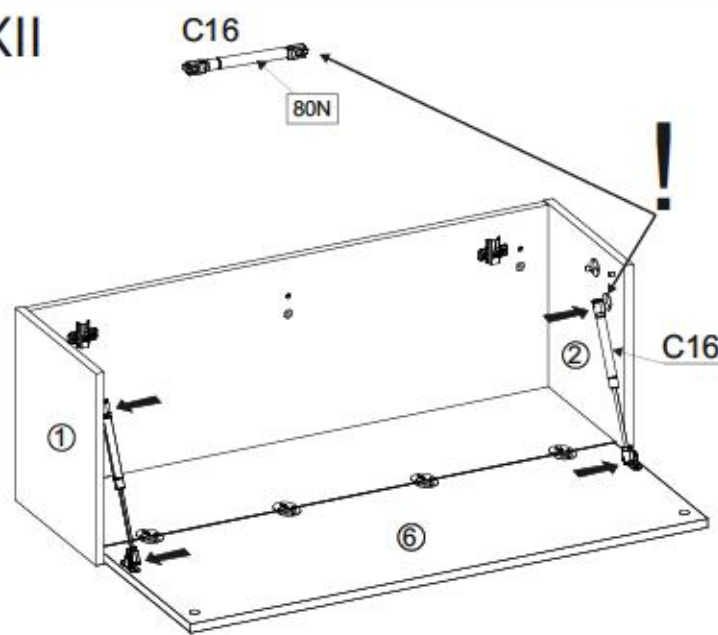



XIII

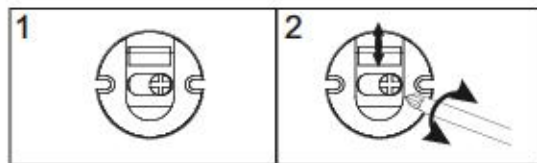
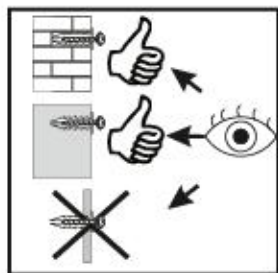
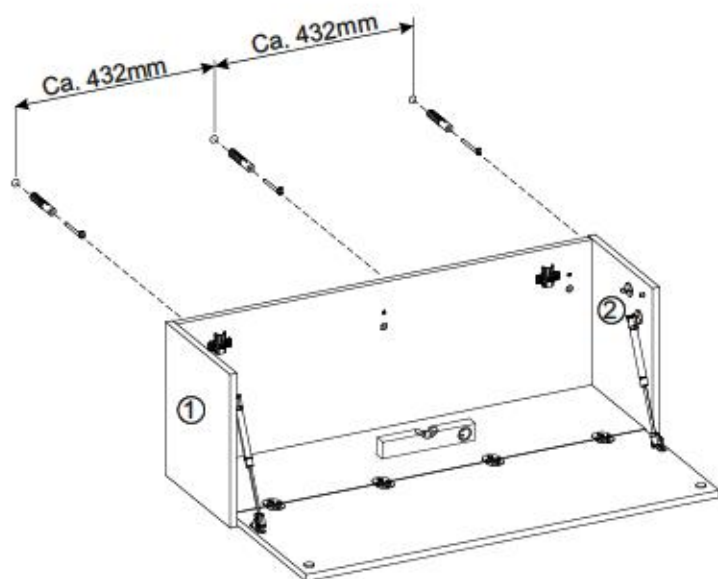
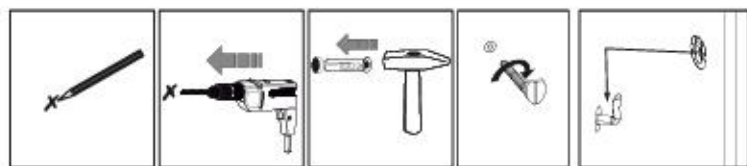
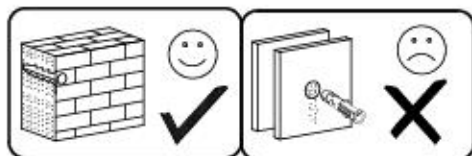

XIV

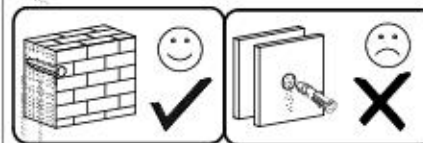
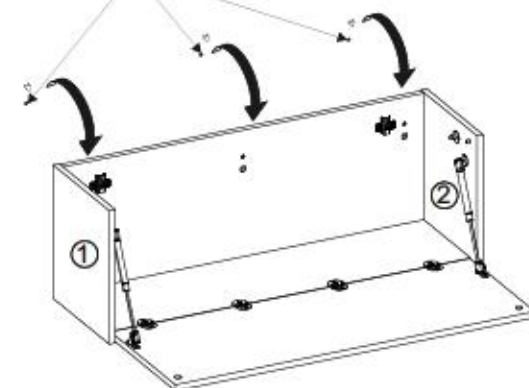
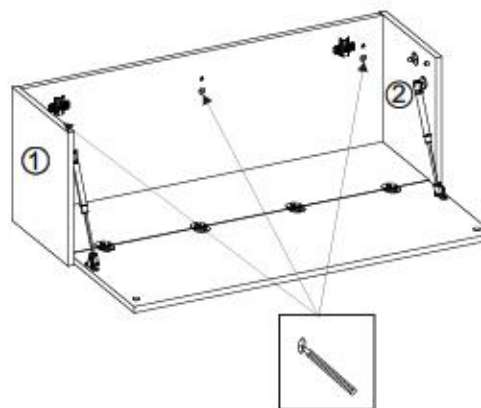
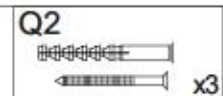

XV

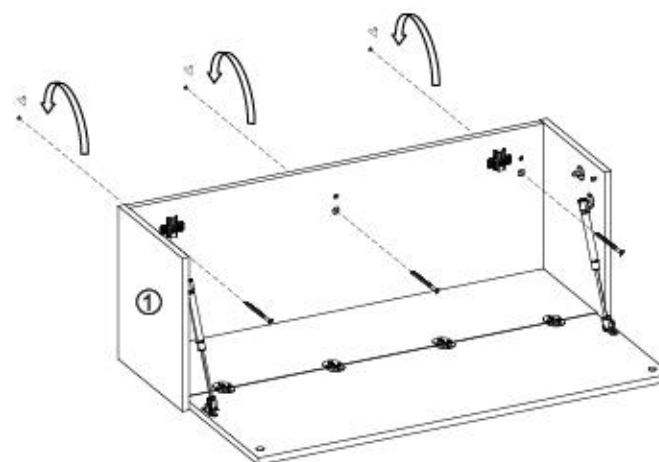
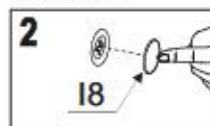
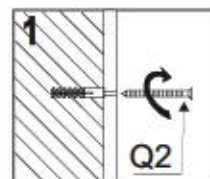

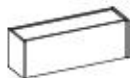

XVI

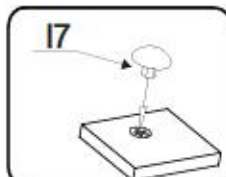
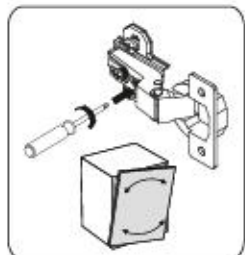
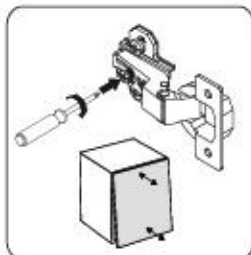
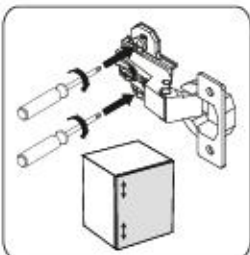
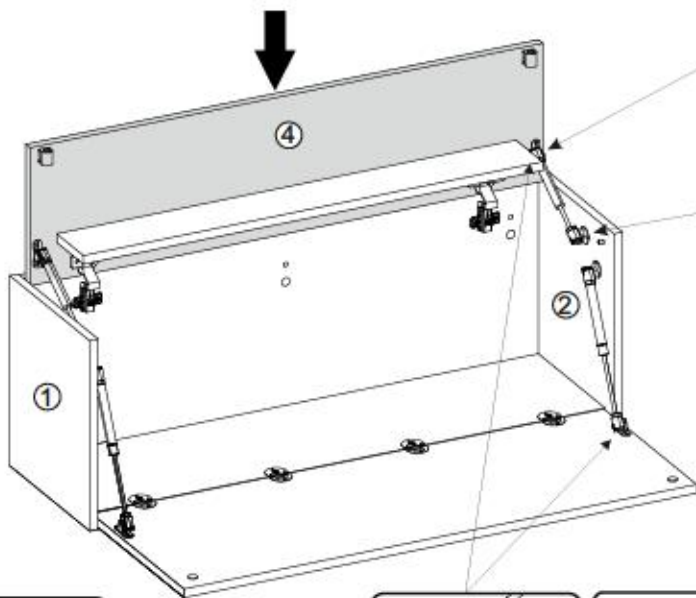
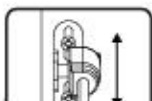
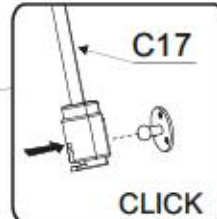
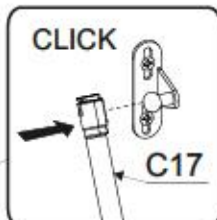
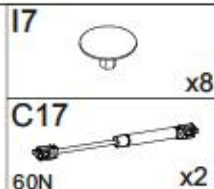
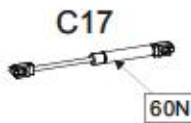
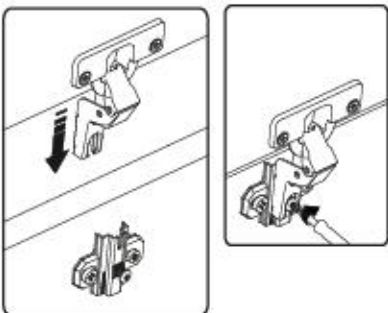

Name • Nom • Nome • Naam • Nazwa • Jméno • Νόμος • Νέν • Denimire • Isim • Имя • Nr • No • N° • Номер • Č • Sz • Typ • Type • Tip • Típus • Tipo • Tun

CITY / GIRON

--

08

D Lirene Dientverlening of Beschäftigte
Sollte Ihnen ein Beschädigt/Fehler, können Sie diese Servicekarte direkt an die untenstehende Adresse mailen. Wir können allerdings nur Beschädigte auf diesem Wege verschicken. Sollten Sie eine andere Beseitigung an Ihrem Möbelstück haben, so wenden sie sich bitte direkt an Ihr Möbelhaus.

GB Our direct order service for filling
If a filling part is missing, you can e-mail this service card directly to the address below. However, we can only send filling parts in this way. If you have any other issues for complete dismantling your item of furniture, please contact your furniture store directly.

CZ Naše příloha slouží pro kování
Chybí-li vám nějaký díl (šroub), můžete tuto servisní kartu odeslat e-mailem přímo na níže uvedenou adresu. Touto cestou však můžeme to odeslat jen díly kování. Pokud byste měli nějaký jiný problém, obraťte se přímo na svého prodejce nábytku.

F Bien étudier la notice de montage
Si vous remarque une erreur, veuillez envoyer directement la présente carte service à l'adresse e-mail indiquée ci-dessous. Cependant, ceci nous permet uniquement d'envoyer des ferrures. Pour tout autre type de réclamation concernant votre meuble, veuillez contacter directement votre magasin d'ameublement.

I Il nostro servizio diretto per i difetti della lavorazione
Qualora Vi dovesse mai notare un pezzo di servizio, allora Vi preghiamo di inviare questa carta di servizio immediatamente all'indirizzo sottostante. Possiamo inviare i pezzi di servizio solamente per mezzo di questo procedimento. Qualora dovesse avere qualche altro problema in merito al mobile, allora Vi preghiamo di rivolgerVi direttamente al Vostro Negozio di mobili.

BG Нашата директна услуга за обслуга
Ако لاحظате част от комплект, поточната настояща карта услуга може да ви бъде изпратена на е-мил адреса, посочен по-долу. Тя може да ви позволи да изпратим само детайли на комплектите от обслуга. Ако установите други дефекти по мебелите, би ви препоръчали да се свържете със мебелите си изпращачите, от който сте закупили стоката.

NL Onze directie voor losse onderdelen
Wanneer er een onderdeel ontbreekt, kunt u deze servicekaart direct aan onze onderdelen-e-mailadres sturen. Wij kunnen langzamerhand wel schroef en losse metalen vastzetten. Mocht u een ander probleem met een meubel hebben, verzoecken wij u contact op te nemen met uw meubeldealer.

PL Nasz bezpośredni serwis części montażowych
Jeżeli brakuje części koniecznych do montażu, prosimy o przesłanie nam niniejszej karty serwisowej na niżej podany adres e-mailowy. W ten sposób możemy przesyłać: Pełniaku tylko brzołogę czepki. W przypadku innych szkłańców dotyczących mebla, prosimy o kontakt z naszym meblowym, w którym został dokonany zakup.

HR Servis za otkove
U slučaju da nedostaje neki od dijelova molimo vas da na dole navedenu mail adresu pošaljete ovaj servisni kartica. Na ovaj način mogu se dostaviti samo otkovi. U slučaju da imate dodatna prigovora vezane uz lošad namještaja molimo vas da se obratite bravno trgovini namještaja gdje je isti kupljen.

HU Direktrendelgetésnek vanaték esetén
Ha hiányzik egy vanaték, ezt a környék kiegészítést elküldhet az alább található címre. Azonban csak a vanatékot tudunk így küldeni. Amennyiben másféle hibaértesítést kell tenniük a hibaértesítést, forduljon közvetlenül a birtokhoz.

SK Náš priamy servis pre čisti kovania
Ak by Vám chýbala nejaká časť kování, môžete poslať túto servisnú kartu e-mailom na nižšie uvedenú adresu. Cieľom kování v tomto prípade iba kování. Ak by ste mali iný problém s nábytkom, obráťte sa priamo na Vašu predajcu nábytku.

SLO Naše direktno uslugotno služba za otkove
Če vam manjka kakikoli otkove, lahko to sporo samo kartico pošljete po e-pošti direktno na spodnji naslov. Po jej postvi vam lahko pošljemo samo otkove. Če imate kakikoli drugi problem s pohištvom, se obrnite neposredno na vašo trgovino pohištvom.

RO Serviciu la nostru direct pentru furnitură
În cazul în care vă lipsește o piesă de mobilier, puteți să trimiteți direct această card de serviu prin e-mail la adresa de mai jos. Noi nu putem expedia piesa de mobilier decât pe această cale. Dacă aveți o altă reclamație referitoare la piesa de mobilier, atunci vă rugăm să vă adresați direct la magazinul dvs. de mobilier.

RUS Наш прямой сервис для поставки фурнитуры
Если вы заметили, что Вам не хватает той или иной комплектной фурнитуры, Вы можете отправить сервисную карту по адресу непосредственно на нижеприведенный адрес электронной почты. Однако, такие образцы мы можем переслать лишь фурнитуру. Если же у Вас возникли иные претензии относительно прочего мебельного комплекта, пожалуйста, обращайтесь непосредственно в магазин, осуществляющий продажу.

S Vår direkte tjena för beställningar
Om du saknar en beställning, kan du skicka detta servicekort direkt till e-postadressen som anges nedan. Tänk på att detta är den enda möjligheten att skicka beställningar till oss. Om du vill reklamera ditt möbel av annan anledning, rikta du kontakten till Möbelhuset direkt.

ES Nuestro servicio directo para accesorios
Si le falta algún accesorio, puede enviar esta tarjeta de servicio directamente a la siguiente dirección. No obstante, por este método solo podemos enviar accesorios. Si tiene alguna otra objeción sobre su mueble, consulte directamente con su mueblería.

TR Doğrudan loto doğrudan servisi
Bir donatıda eksiklik ya servisi kartını doğrudan aşağıdaki buharan adrese doğrudan mail ile yollayabilirsiniz. Ancak bu yolla donatılar gönderilemez. Mobilyanızda başka şikayetleriniz varsa lütfen doğrudan mobilya satıcınıza derişin.

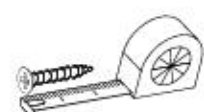

E6	F4	B1
x...	x...	x...
I7	K1	K10
x...	x...	x...
C6	D4	G34
x...	x...	x...
G52	P10	C20
x...	x...	x...
5x11	C17	Q2
x...	x...	x...
C16		
80N		
x...		
I8		
x...		



Name • Nom • Nome • Naom • Nazwa • Иméно
• Názov • Névn • Denimire • Isim • Извание

CITY / GIRON

Nr • No • N° • Номер • Č • Sz

Typ • Type • Tip • Típus • Tipo • Тип

08

D Unsere Dienstleistung ist für Deutschland
Sollten Ihnen ein Beschädigt haben, können Sie diese Servicekarte
direkt an die untenstehende Adresse mailen. Wir können sie auch
nur Beschädigt in auf diesem Wege verschicken. Sollten Sie eine
andere Botschaft an Ihren Möbelstück haben, so werden sie
sich bitte direkt an Ihr Möbelhaus.

GB Our direct order card is for filling
If a filling part is missing, you can e-mail this service card directly
to the address below. However, we can only send filling parts in
this way if you have any other claims for complaint concerning
your item of furniture, please contact your furniture store directly.

CZ Náš přímý službu pro kování
Chytl-li vám nějaký díl z kování, můžete tuto službu kartu odeslat
e-mailem přímo na níže uvedenou adresu. Touto cestou však
můžete rovněž jen díly kování. Pokud byste měli nějaký jiný
nářek, obraťte se přímo na svého prodejce nábytku.

F Si un article de la notice de montage
Il vous manque une ferrure, veuillez envoyer directement la présente
carte service l'adresse e-mail indiquée ci-dessous. Cependant, ceci
nous permet uniquement d'envoyer des ferrures. Pour tout autre type
de réclamation concernant votre meuble, veuillez contacter
directement votre magasin d'aménagement.

I Il nostro servizio di aiuto per il ordine dei ferromenti
Qualora Vi dovesse mancare un pezzo di fissaggio, allora Vi
preghiamo di inviarci questa carta di servizio immediatamente
affinché il pezzo arrivati. Possiamo inviare i pezzi di fissaggio
solamente per mezzo di questo procedimento. Qualora dovete
avere qualche altra reclamazione in merito al mobile, allora Vi
preghiamo di rivolgerVi direttamente al Vostro Negozio di mobili.

BG Нашата директна услуга за облек
Ако липкат част от комплекта, потърсете настоящата
карточка директно и ни я изпратете на e-mail адреса, посочен
по-долу. По този начин можем да доставим само липваща
компонент от облекта. Ако установите други дефекти по
мобил или, Ви съветваме да се обърнете към мебелната
изпълнителят, от който сте закупили облекта.

NL Onze directservice voor losse onderdelen
Wanneer er een onderdeel ontbreekt, kunt u deze servicekaart
direct aan onderstaand e-mailadres sturen. Wij kunnen langzame
weg echter alleen bestaande vervullen. Mocht u een ander
probleem aan uw meubel hebben, verzoek wij u contact op te
nemen met uw meubeldealer.

PL Nasz bezpośredni serwis części montażowych
Jeżeli brakuje części koniecznych do montażu, prosimy o przesłanie
nasz formularz karty serwisowej na niżej podany adres e-mailowy.
W ten sposób możemy przesyłać Państwu tylko brakujące części.
W przypadku innych niż awarie dotyczących mebla, prosimy zgłaszać
sprawy do własnego meblowego, w którym został dokonany zakup.

HR Servis za oblake
U slučaju da nedostaje neki od dijelova mobilnog vas da na dolje
navedenu mail adresu pošaljete našu službu karticu. Na ovaj način
možemo sa dostaviti samo dijelove. U slučaju da imate dodatne prigovore
vezane uz komad namještaja mobilnog vas da se obratite izravno
izgovornj namještajnoj trgovini iz koje je mobli kupljen.

HU Direktaczi gátlakunk vasalok esetén
Ha hiányzik egy vasalat, ezt a kártyát közvetlenül elküldheti az
alább található címre. Azonban csak azt tudunk elküldni így
küldés. Amennyiben másfajta reklamációt áll ten kárelőzést
kellően, forduljon közvetlenül a boltüzeméhez.

SK Náš priamy servis pre štít kování
Ak by Vám chýbala niekajá časť kování, môžete poslať
túto službu kartu priamo e-mailom na nižšie uvedené
adresu. Cieľom kování vieme poslať iba týmto spôsobom.
Ak by ste mali inú námietku ohľadom vášho nábytku,
obráťte sa priamo na Vašu predajňu nábytku.

SLO Náš direktni uslužba storitev za delnice
Če vam manjka kakšno delnico, lahko to serviso kartico pošljete
po e-pošti direktno na spodnji naslov. Po tej poti vam lahko
pošljemo samo delnice. Če delite nekatere kakšne druge del
pohitke, se obrnite neposredno na vašo trgovino pohitke.

RO Servisul direct pentru feronerie
In cazul care va lipseste o piesa de feronerie puteti sa trimitezi
direct acest card de service prin e-mail la adresa de mail jos. Noi
nu putem expedia piesa de feronerie d e alt fel decat prin
Dacă aveți o altă reclamație referitoare la piesa de mobilier,
sunți să vă rugăm să vă adresați direct la magazinul dvs. de mobilă.

RUS Наш прямой сервис для поставки фурнитуры
Если обнаружено, что Вы не получили того или иного элемента
фурнитуры, Вы можете отправить сервисную карту по адресу
непосредственно на нижеуказанный адрес электронной
почты. Однако, также об этом мы можем передать лишь
фурнитуру. Если у Вас возникнут иные претензии относительно
приобретенной мебели, пожалуйста, обращайтесь
непосредственно в организацию, осуществляющую продажу.

S M'r direktaczi na f'r bestelorder
Om du missar en bestelorder kan du skicka detta servicekort till
Här-proceduren som anges nedan. Tänk på att detta är den enda
m'gheten att skicka bestelorder till dig. Om du vill klaga på
mobli av annan anledning m'la du kontakta ditt m'belhus direkt.

ES Nuestro servicio directo para accesorios
Si le falta algún accesorio, puede enviar esta tarjeta de servicio directamente
a la siguiente dirección. No obstante, por este método solo podemos
enviar accesorios. Si tiene alguna otra objeción sobre su mueble, consulte
directamente con su mueblista.

TR Donatlar için doğrudan servisi için
Eğer donatılar eksikse bu servisi kartını doğrudan aşağıdaki bu adresine
doğrudan mail ile gönderebilirsiniz. Ancak bu yolu donatılar dışında diğer
mobilya ile ilgili diğer sorunlar için doğrudan mobilya satıcınıza
başvurmanız gerekir.

nr	L[mm]	B[mm]	T[mm]	Wenge	Coli
1	350	300	16	1	1/1
2	350	300	16	1	1/1
3	968	266	16	1	1/1
4	962	254	16	1	1/1
5	862	100	16	1	1/1
6	962	344	16	1	1/1
7	968	332	16	1	1/1

