

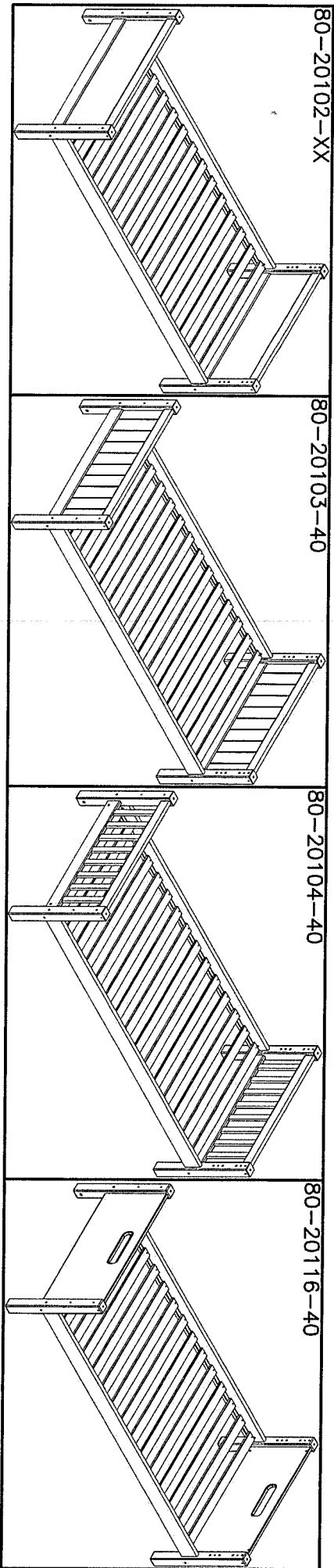









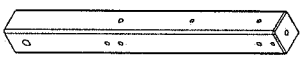
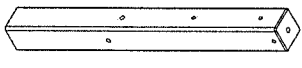
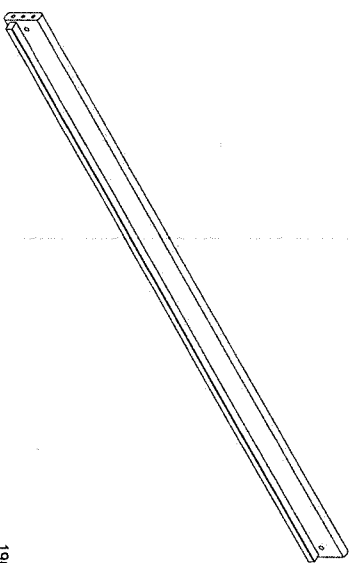

# 80-20101-40



See assembly instruction in box no.  
 Voir notice de montage dans la coïsse no.  
 Siehe Aufbauanleitung im Karton no.  
 Zie voor de montage-instructie pakketnr.

<p>Before assembling this product, please ensure that all the components supplied comply with the list on this page. All Screw-type fittings can be tightened with this tool.</p> 	<p>Avant de commencer l'assemblage, veuillez contrôler si tous les objets indiqués sont présents. Tous les vis peuvent être serrés par cet outil.</p> 	<p>Bevor Sie mit dem Aufbau beginnen, kontrollieren Sie ob alle auf der Zeichnung angegebenen Teile vorhanden sind. Bitte verwenden Sie zur Montage einen Kreuzschraub-ziehler und den beiliegenden Innesschraubenschlüssel.</p> 	<p>Wage-nr. Part no. Réf. No.</p> <p>Stück- Qty. Qté.</p> <p>Mass Dim. Dim.</p>
---	---	--	---

<p>12-06306473-40</p>  <p>2 stick/pcs.</p>	<p>12-06306474-40</p>  <p>2 stick/pcs.</p>	<p>1305-19672-40</p>  <p>2 stick/pcs.</p>	<p>647x63x63 B</p> <p>3922-08018 8 stick/pcs.</p> <p>3930-10050 16 stick/pcs.</p> <p>3909-70100 30 stick/pcs.</p> <p>647x63x63 C</p> <p>4 stick/pcs.</p> <p>3901-40030 30 stick/pcs.</p> <p>1967x115x26</p>
---	---	---	---

<p>Z1</p> <p>M6/ø12x18 mm.</p> <p>3913-08110</p> 	<p>Z2</p> <p>ø10x50 mm.</p> <p>8 stick/pcs.</p> <p>3938-000081-2</p> 	<p>Z3</p> <p>16 stick/pcs.</p> <p>3938-00010-2</p> 	<p>Z4</p> <p>ø7x100 mm.</p> <p>20 stick/pcs.</p> <p>3938-00016-2</p> 
<p>Z5</p> <p>M8x110 mm.</p> <p>88 mm.</p> <p>Z6</p> <p>ø10 mm.</p> <p>Z7</p> <p>ø16 mm.</p> <p>Z8</p> <p>ø4x30 mm.</p> <p>4 stick/pcs.</p> <p>4033-005</p> <p>1 stick/pcs.</p> <p>5 mm.</p>	<p>Z9</p> <p>16 stick/pcs.</p> <p>3938-00016-2</p> 	<p>Z10</p> <p>4 stick/pcs.</p> <p>3938-00016-2</p> 	<p>Z11</p> <p>1 stick/pcs.</p> <p>4033-005</p> 

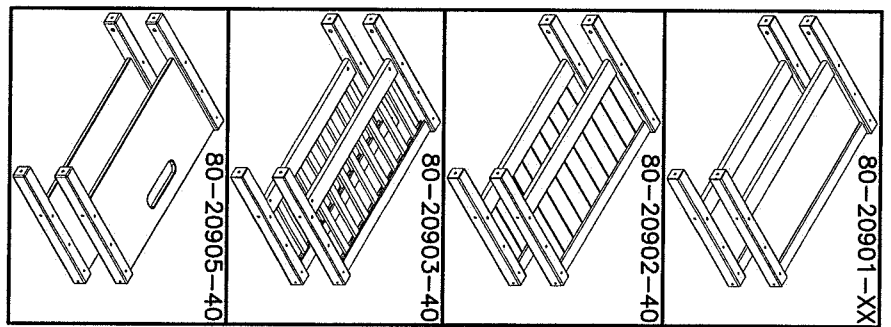

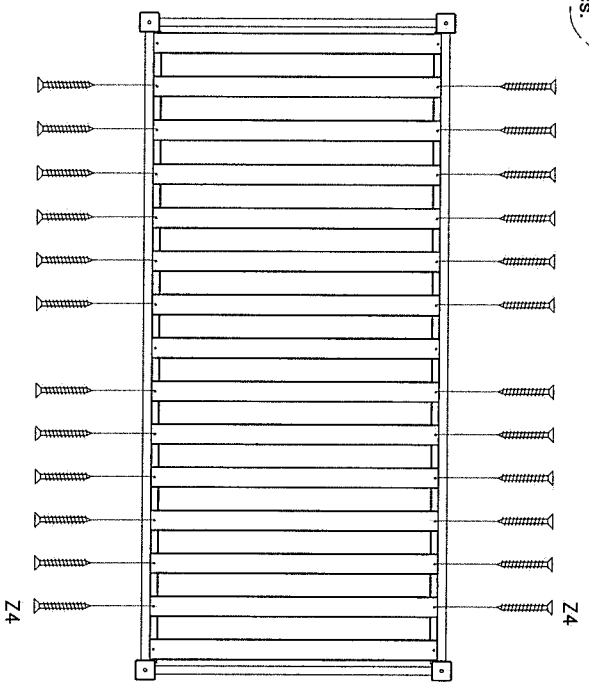
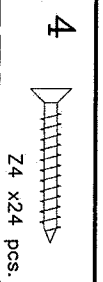
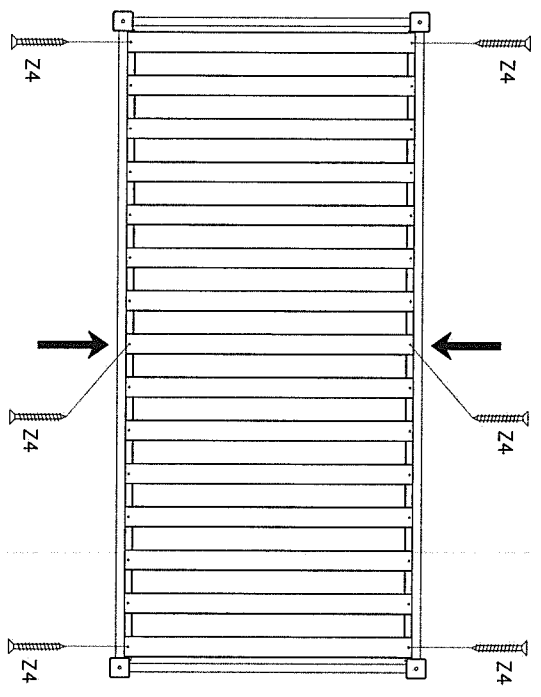
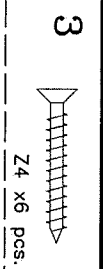
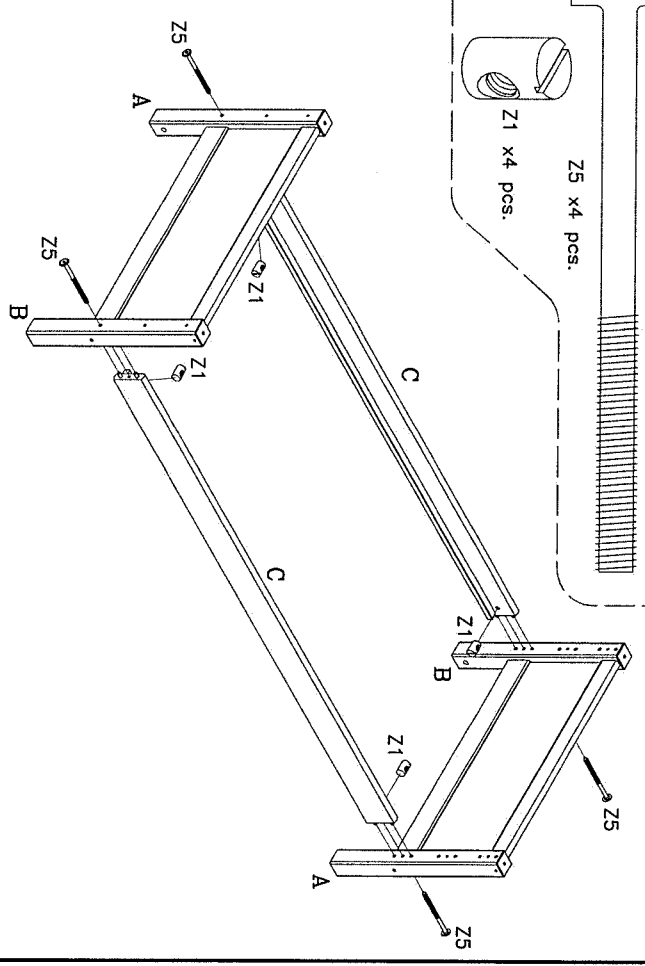
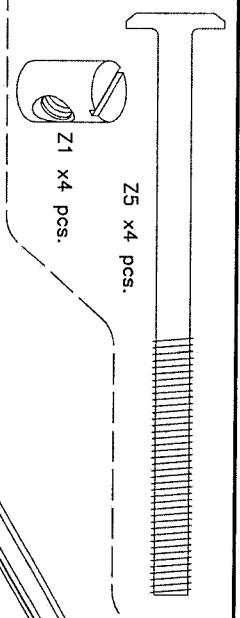
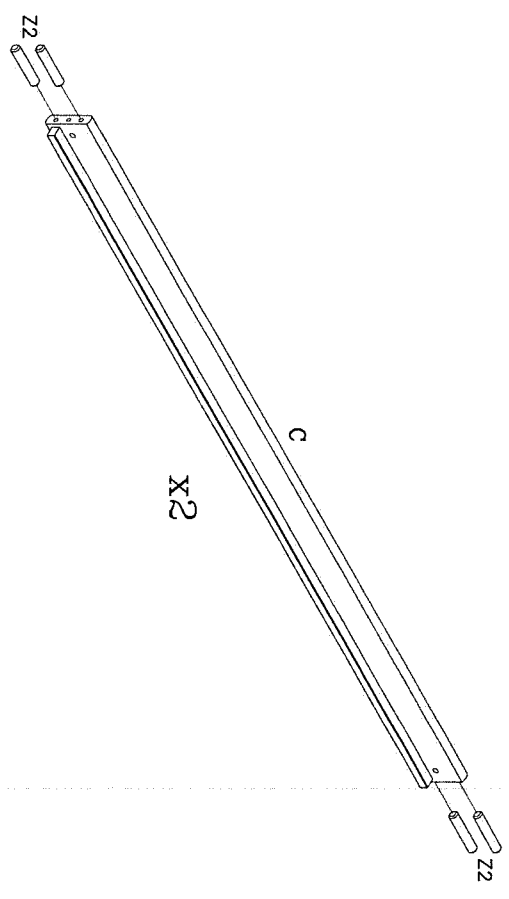
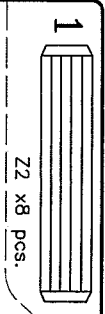

# 80-20905-40 White

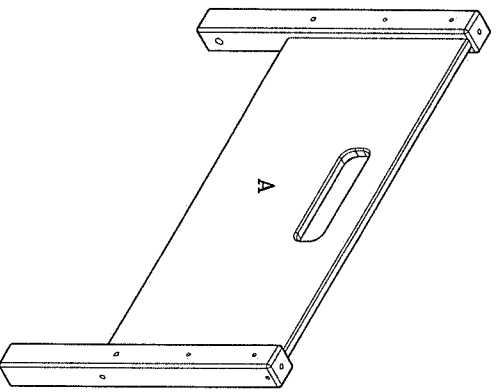

<p>Before assembling this product, please ensure that all the components supplied comply with the list on this page. All Screw-type fittings can be tightened with this tool.</p>	<p>Avant de commencer l'assemblage, veuillez contrôler si tous les objets indiqués sont présents. Tous les vis peuvent être serrés par cet outil.</p>	<p>Bevor Sie mit dem Aufbau beginnen, kontrollieren Sie ob alle auf der Zeichnung angegebenen Teile vorhanden sind. Bitte verwenden Sie zur Montage einen Kreuzschraub-zähler und den beiliegenden Innensechskantschlüssel.</p>	<p>Wage- nr. Part no. Ref No</p>	<p>Sack- Qty. Qty. Qté.</p>
---	---	---	--	-------------------------------------

4301-2208631-40	2 stick/pcs.	M6/Ø10x18mm	4 stick/pcs.	4033-004	1 stick/pcs.
A	863x431x22	Z29	M6x110 mm.	Z28	4 mm.

Z1, Z2, Z5 Fittings in single / bunk bed box.  
 Z1, Z2, Z5 Beschläge im Einzel- / Etagenbett Karton.  
 Z1, Z2, Z5 Raccords en lit simple / lit superposé.  
 Z1, Z2, Z5 Fittings in het enkelbed / stapelbed boxen.

<p><b>1</b></p> <p>Z2 x8 pcs.</p>	
<p><b>2a</b></p> <p>Z29 x2 pcs. Z5 x2 pcs. Z1 Z28</p>	
<p>Bunk bed only, Nur Etagen Bett.                  Lits superposés seulement. Alleen stapelbed</p>	
<p><b>2b</b></p> <p>Z29 x2 pcs. Z5 x2 pcs. Z1 Z28</p>	
<p><b>3a</b></p> <p>Z29 x2 pcs. Z5 x2 pcs. Z1 Z28</p>	
<p><b>3b</b></p> <p>Z29 x2 pcs. Z5 x2 pcs. Z1 Z28</p>	

# 80-20601-40

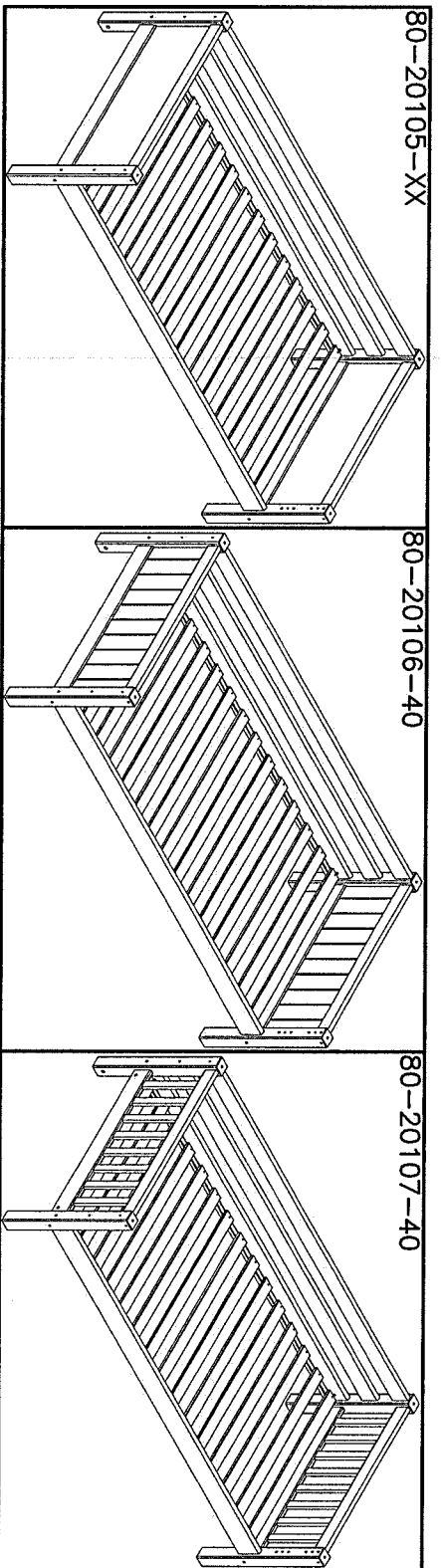

Before assembling this product, please ensure that all the components supplied comply with the list on this page. All Screw-type fittings can be tightened with this tool.

Avant de commencer l'assemblage, veuillez vérifier que tous les objets incluses sont présents. Tous les vis peuvent être serrés par cet outil.

Bevor Sie mit dem Aufbau beginnen, kontrollieren Sie ob alle auf der Zeichnung angegebenen Teile vorhanden sind. Bitte verwenden Sie zur Montage einen Kreuzschraubenzieher und den beiliegenden Innensechskantschlüssel.

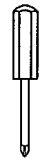

Waren-nr.  
Part no.  
Ref No

Stück.  
Qty.  
Qté.

Siehe Bild-nr.  
See picture no.  
Image no

Mess  
Dim.  
Dim.

12-02619676-40

2 stick/pcs.

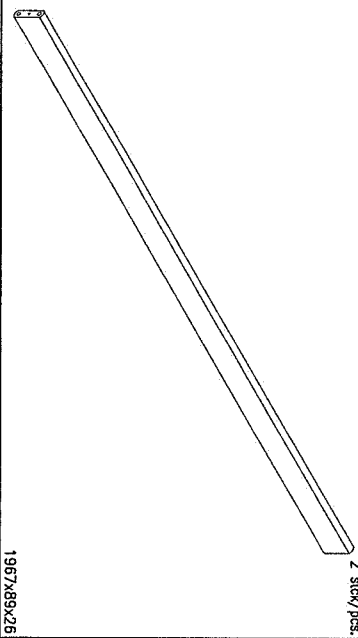

A  
3930-10050 8 stick/pcs. 3909-70100

4 stick/pcs.



Z2 ø10x50 mm. Z3 ø7x100 mm.

See assembly instruction in box no. 80-20101-40

Voir notice de montage dans la caisse no. 80-20101-40

Siehe Aufbauanleitung im karton no. 80-20101-40

Zie voor de montage-instructie pakkeotr. 80-20101-40

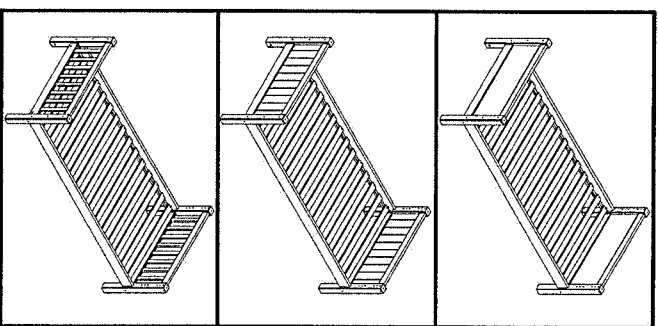



Z2 x8 pcs.

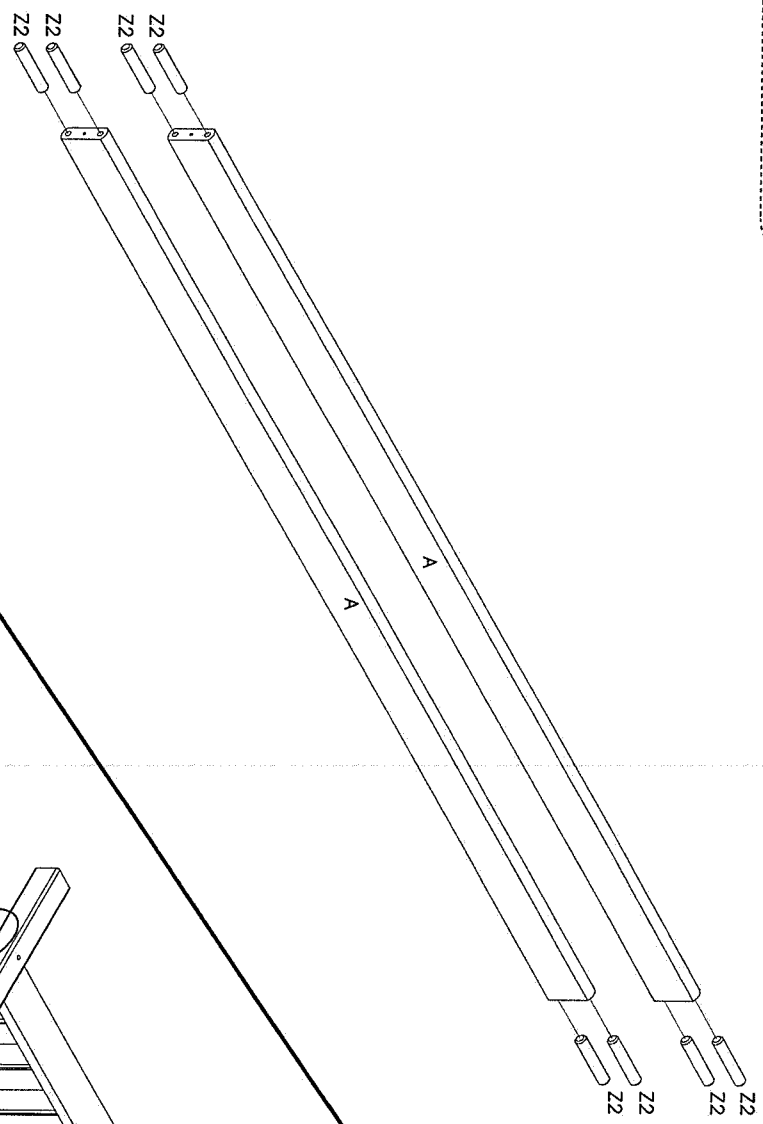

2

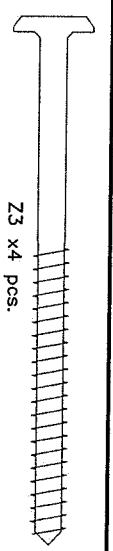

Z3 x4 pcs.

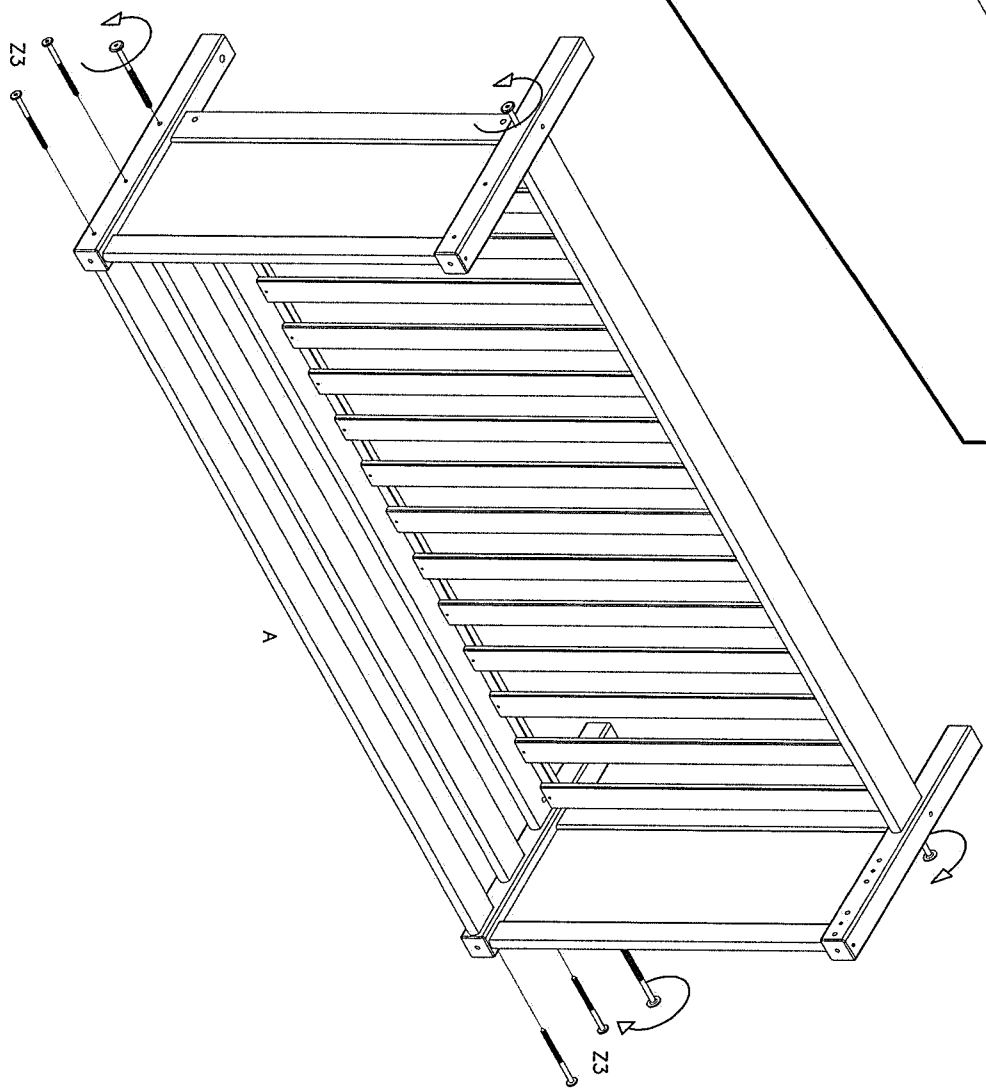

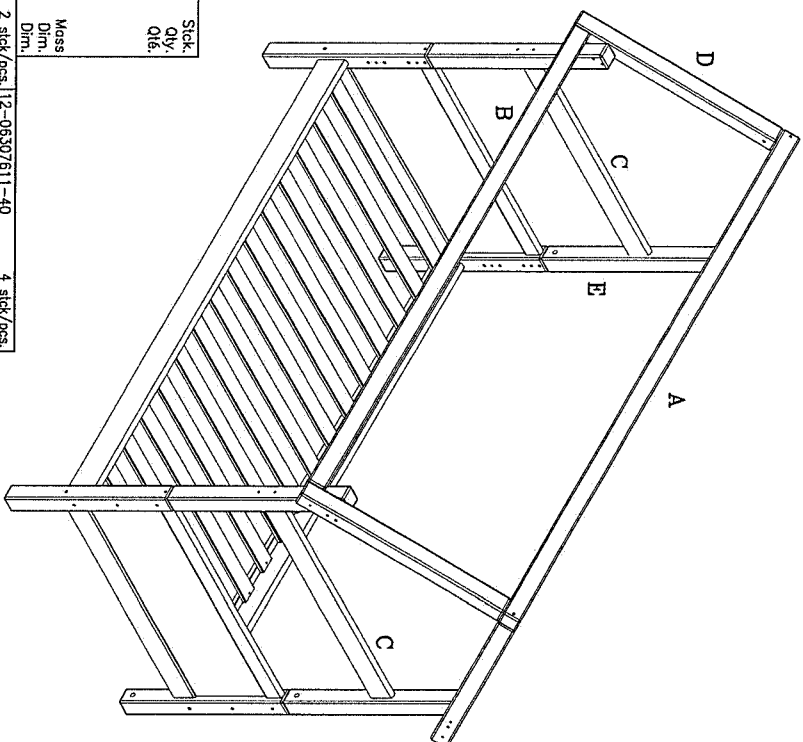

Before assembling the product, please ensure that all the components supplied comply with the list on this page. All Screw-type fittings can be tightened with this tool.

Avant de commencer l'assemblage, veuillez contrôler si tous les objets indiqués sont présents dans votre série per set outli.

Bevor Sie mit dem Aufbau beginnen, kontrollieren Sie ob alle angegebenen Teile sind. Bitte verwenden Sie zur Montage einen Kreuzschraub-zähler und den beiliegenden Innensechskantschlüssel.

12-06322191-40					Ware-nr. Part no. Réf. No.	Stück- Qty. Qté.
12-06320931-40					Siehe Bild-nr. See picture no. Image no.	Mass Dim. Dim.

12-02608634-40		12-06307001-40		12-06307611-40	
2	2	4	4	4	4
Stück/pcs.	Stück/pcs.	Stück/pcs.	Stück/pcs.	Stück/pcs.	Stück/pcs.
2219x63x63	2219x63x63	2093x63x63	3933-15028	863x89x26	700x63x63
4	4	4	4	4	4
Stück/pcs.	Stück/pcs.	Stück/pcs.	Stück/pcs.	Stück/pcs.	Stück/pcs.
3930-10050	3917-10012	3933-15028	3930-08040	3934-10080	4033-004
8	8	4	4	4	2
Stück/pcs.	Stück/pcs.	Stück/pcs.	Stück/pcs.	Stück/pcs.	Stück/pcs.
Z2	Z3	Z11	Z17	Z19	Z21
Ø10x50 mm.	Ø7x100 mm.	M10x12 mm.	Ø15x28 mm.	Ø8x40 mm.	Ø10x80 mm.
4	4	4	4	4	4
Stück/pcs.	Stück/pcs.	Stück/pcs.	Stück/pcs.	Stück/pcs.	Stück/pcs.
3938-00016-2	3913-06120	3922-06020	3922-06048	3923-06015	4033-005
4	4	4	4	8	1
Stück/pcs.	Stück/pcs.	Stück/pcs.	Stück/pcs.	Stück/pcs.	Stück/pcs.
Z8	Z28	Z29	Z30	Z31	Y
Ø16 mm.	M6/Ø10x20 mm.	M6/Ø10x20 mm.	M6/Ø10x48 mm.	Ø8/M6x15 mm.	150x12x1 mm.
4	4	4	4	8	1
Stück/pcs.	Stück/pcs.	Stück/pcs.	Stück/pcs.	Stück/pcs.	Stück/pcs.
3938-00016-2	3913-06120	3922-06020	3922-06048	3923-06015	4033-005
4	4	4	4	8	1
Stück/pcs.	Stück/pcs.	Stück/pcs.	Stück/pcs.	Stück/pcs.	Stück/pcs.
Z8	Z28	Z29	Z30	Z31	Y
Ø16 mm.	M6/Ø10x20 mm.	M6/Ø10x20 mm.	M6/Ø10x48 mm.	Ø8/M6x15 mm.	150x12x1 mm.
4	4	4	4	8	1
Stück/pcs.	Stück/pcs.	Stück/pcs.	Stück/pcs.	Stück/pcs.	Stück/pcs.

See assembly instruction in box no. 80-20101-40

Voir notice de montage dans la caisse no. 80-20101-40

Siehe Aufbauanleitung im Karton no. 80-20101-40

Zie voor de montage-instructie pakketnr. 80-20101-40

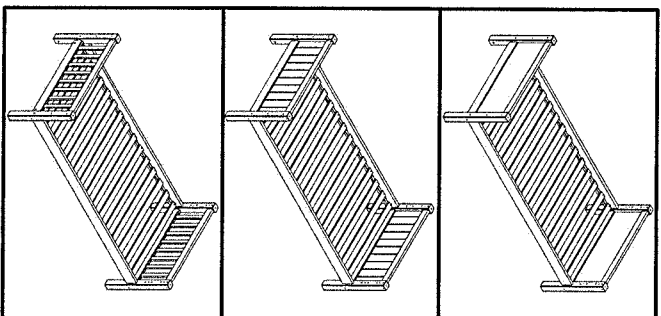

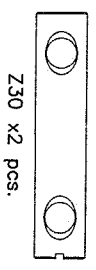
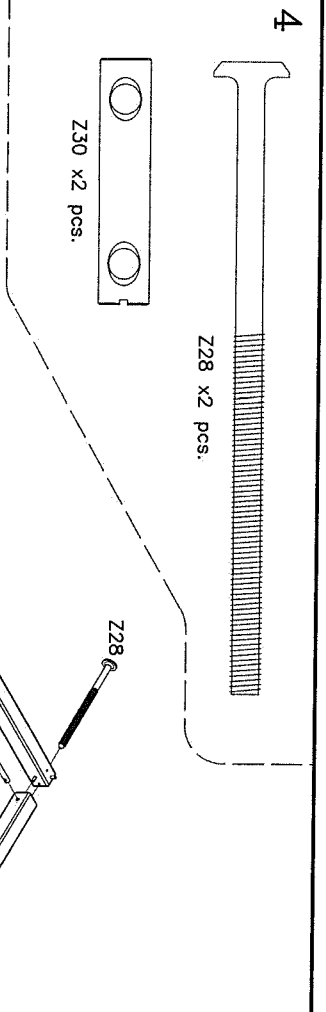
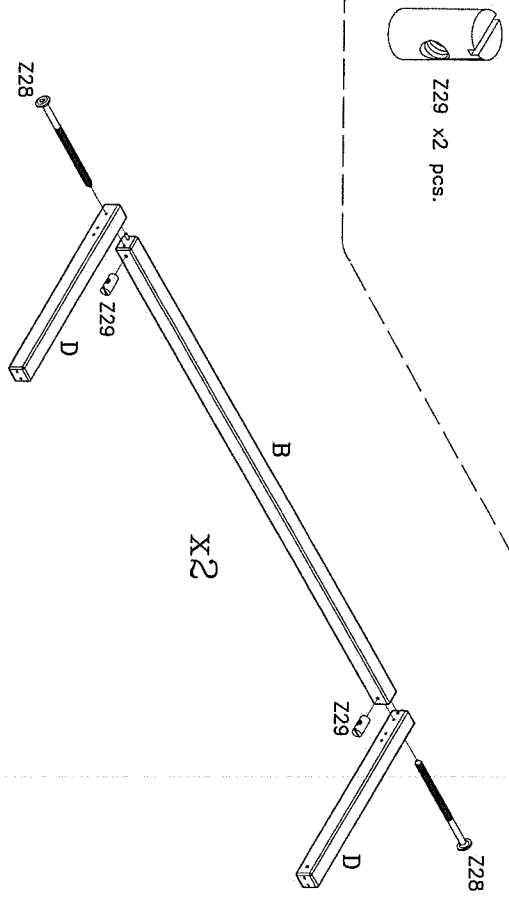
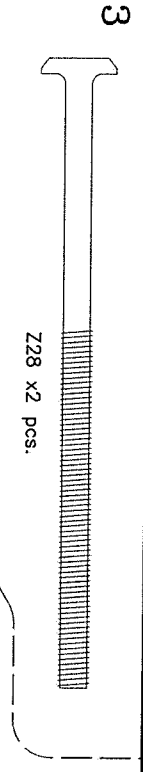
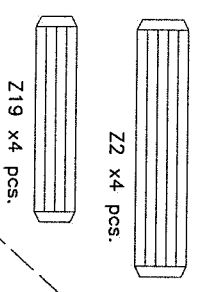
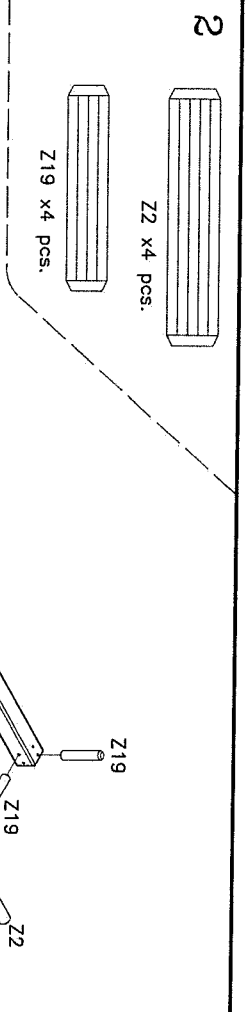
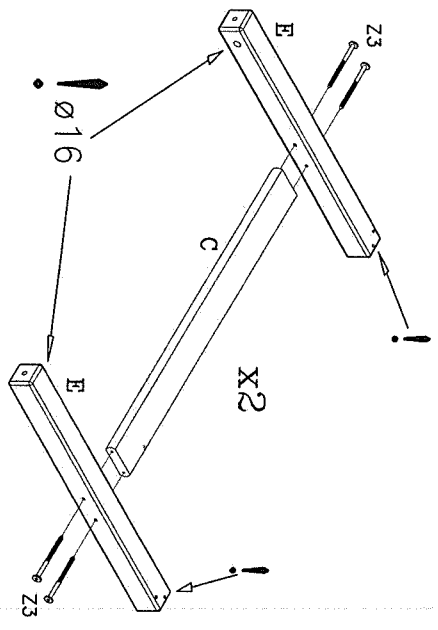
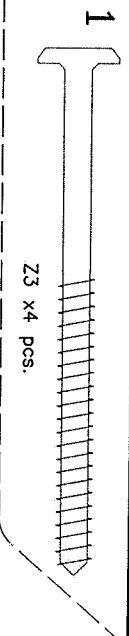

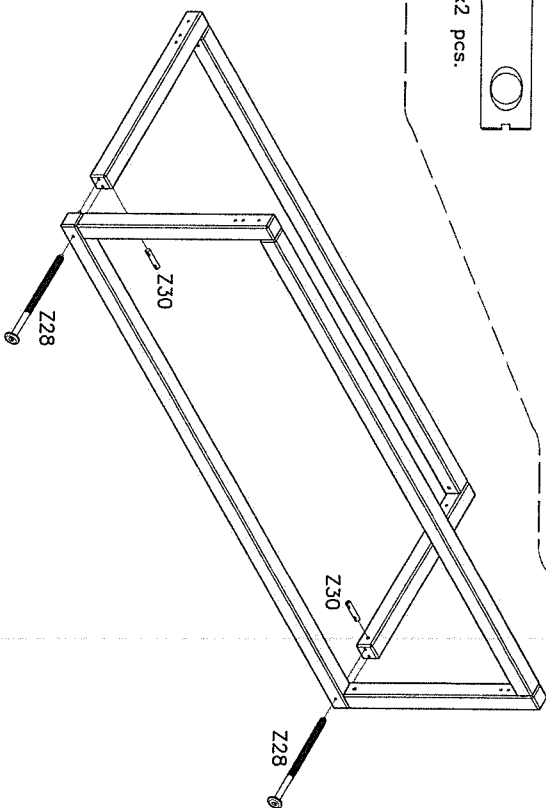
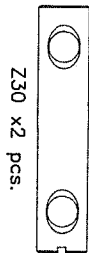
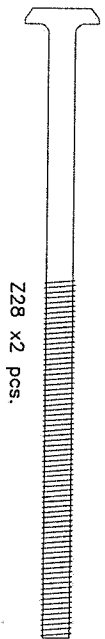

6

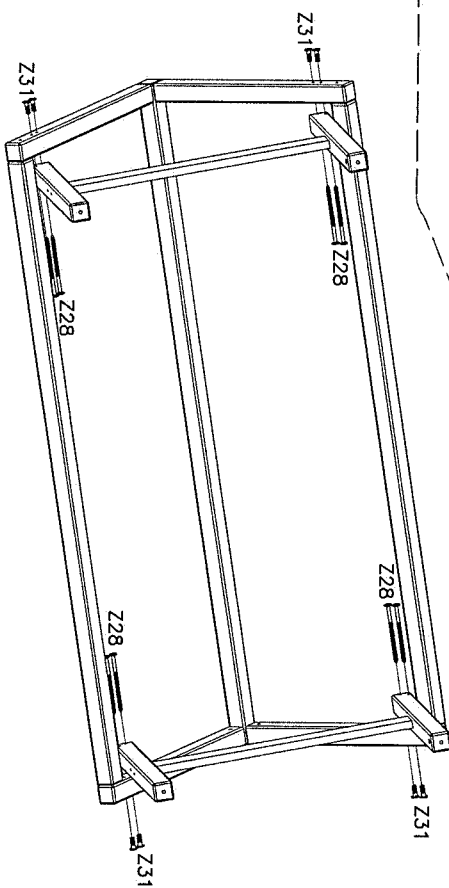
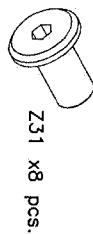
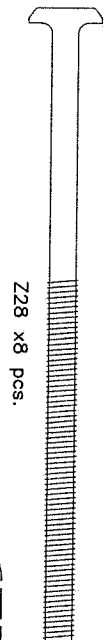

7

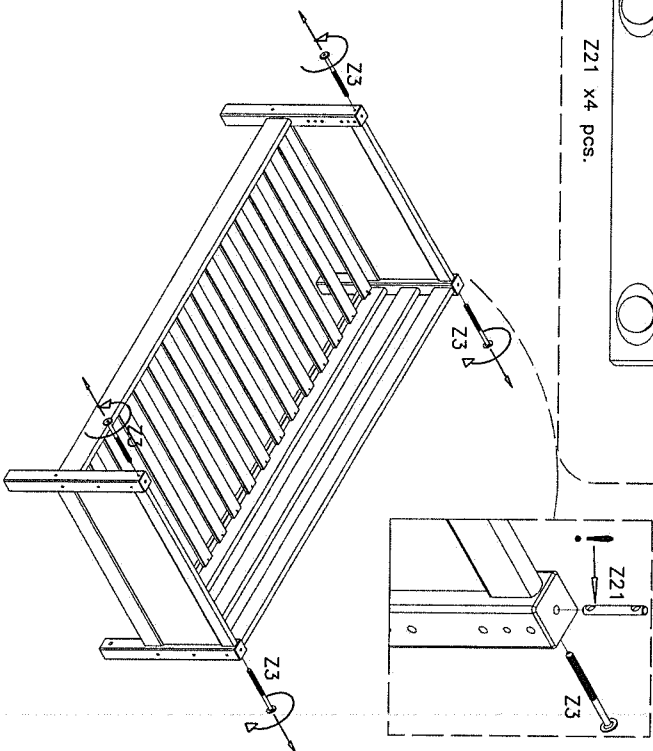
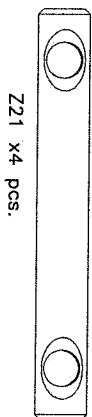

8

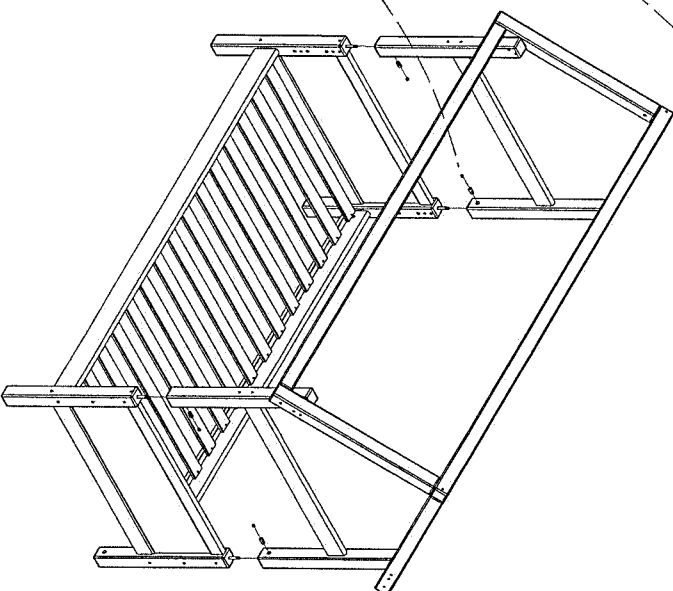
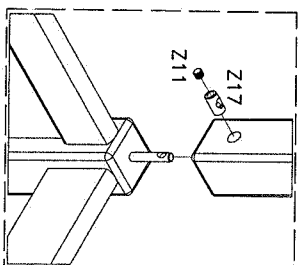
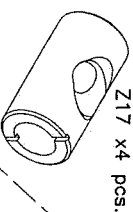



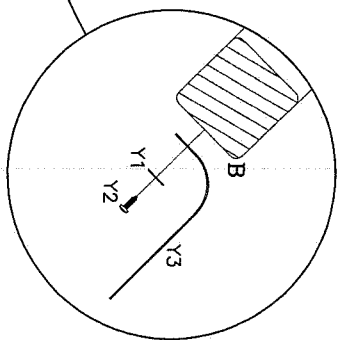
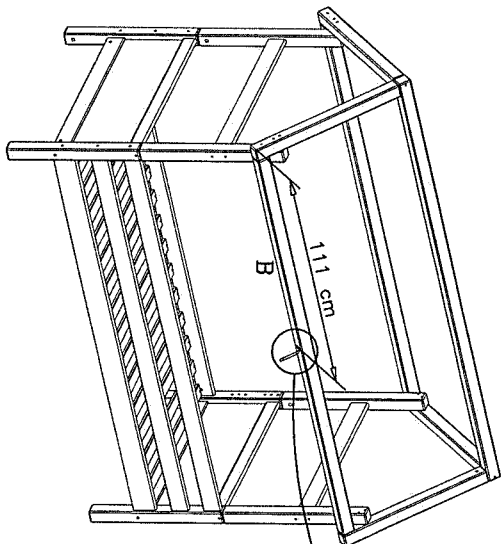
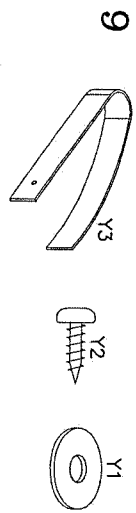

10

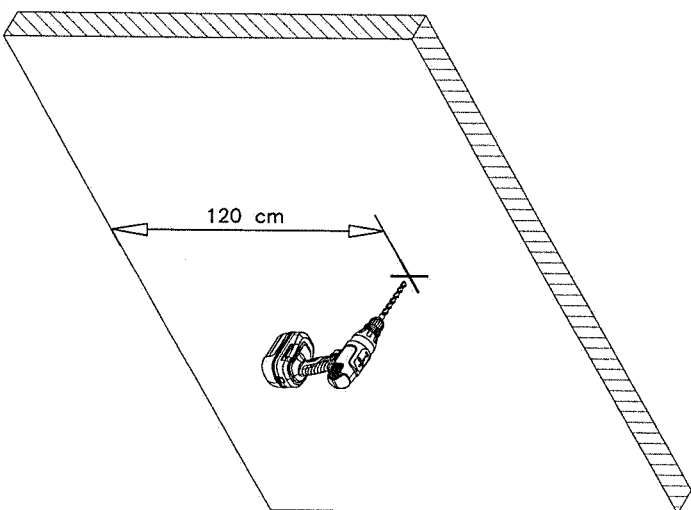

11

