

HAMAR 2066

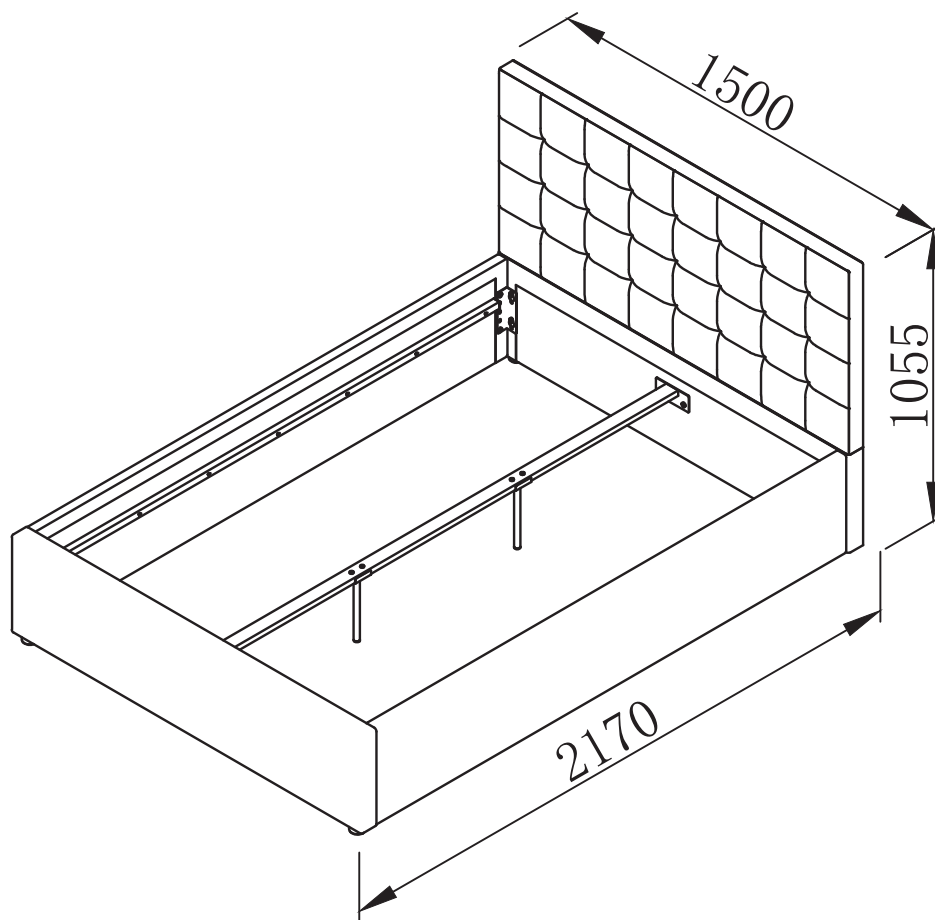

- | | |
|----------------------------------|------------------------------|
| (D) Montageanleitung | (GB) Assembly instructions |
| (FR) Notice de montage | (IT) Istruzioni di montaggio |
| (NL) Handleiding voor de montage | (PL) Instrukcja montażu |
| (CZ) Montážní navod | (SK) Návod na montáž |
| (HU) Szerelési útmutató | (RO) Instrucțiuni de montaj |
| (TR) Montaj talimatı | (RU) |

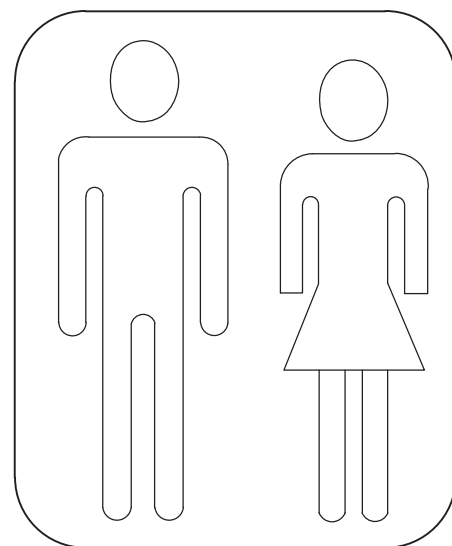

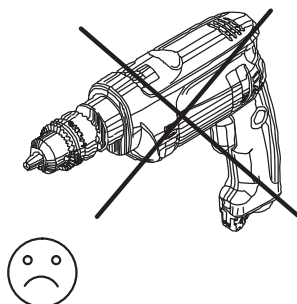
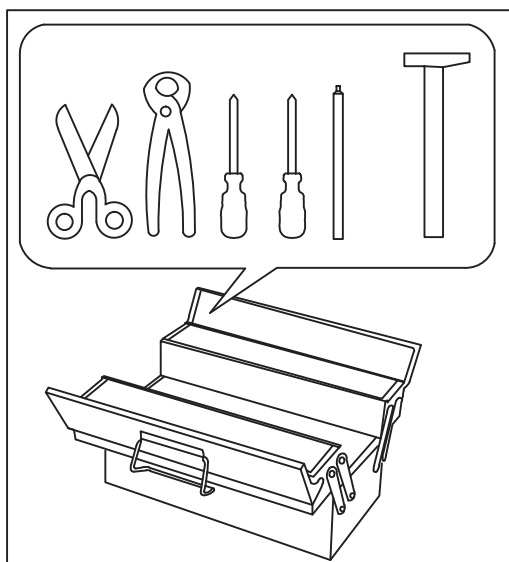
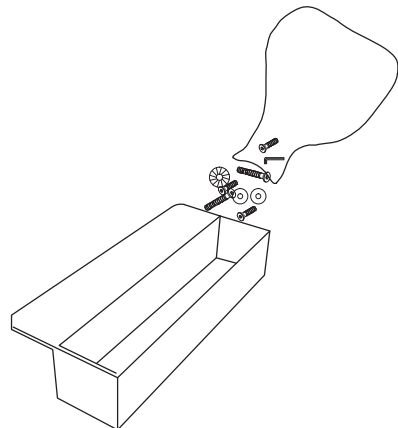
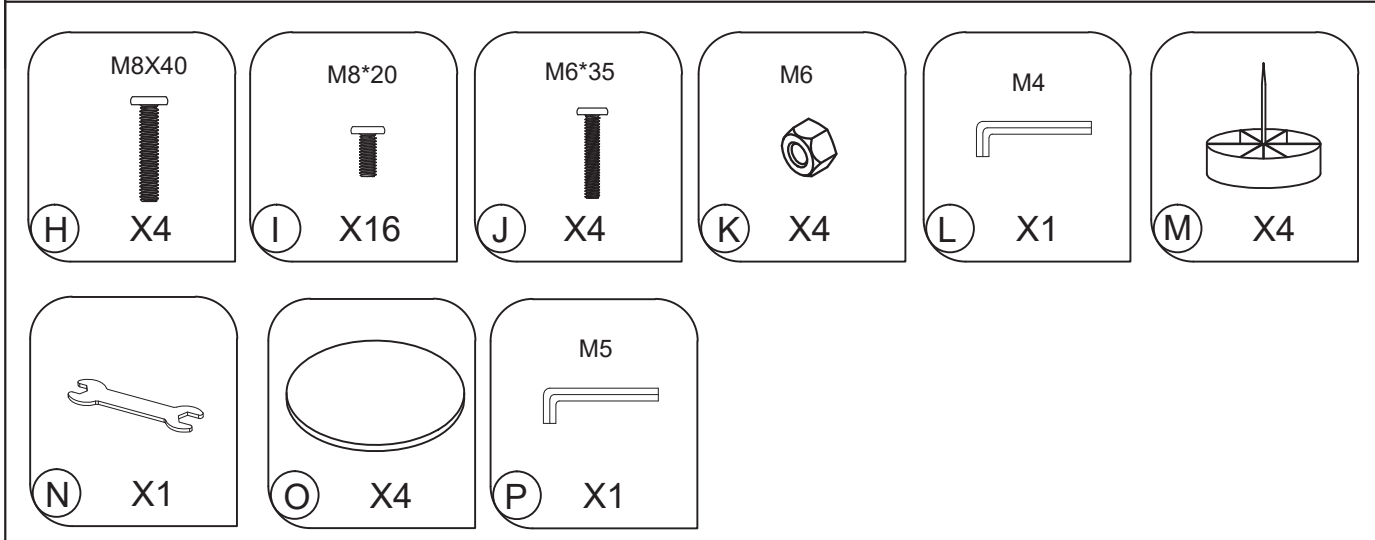
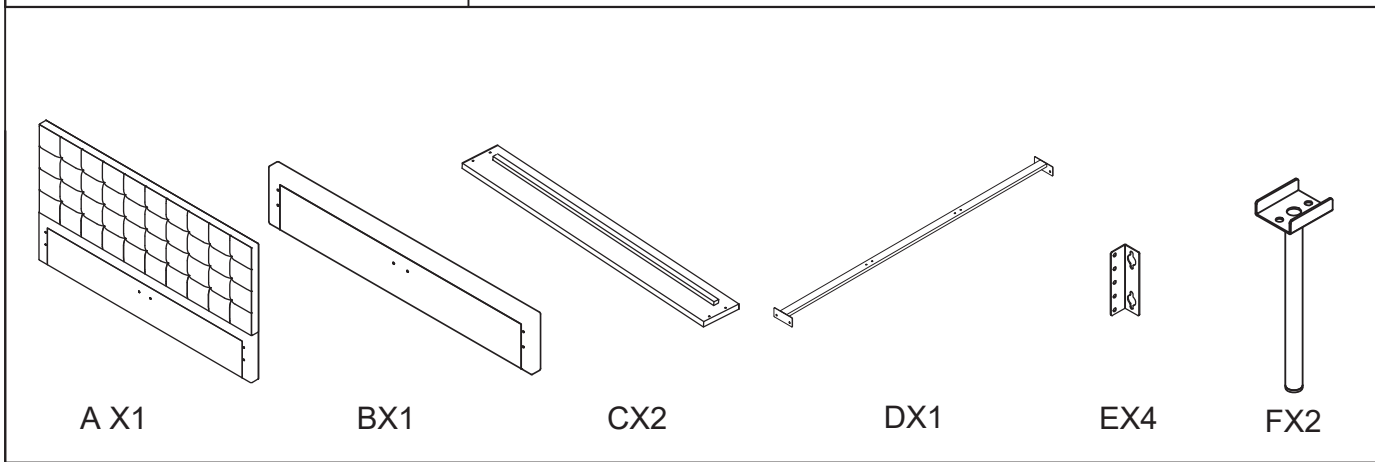
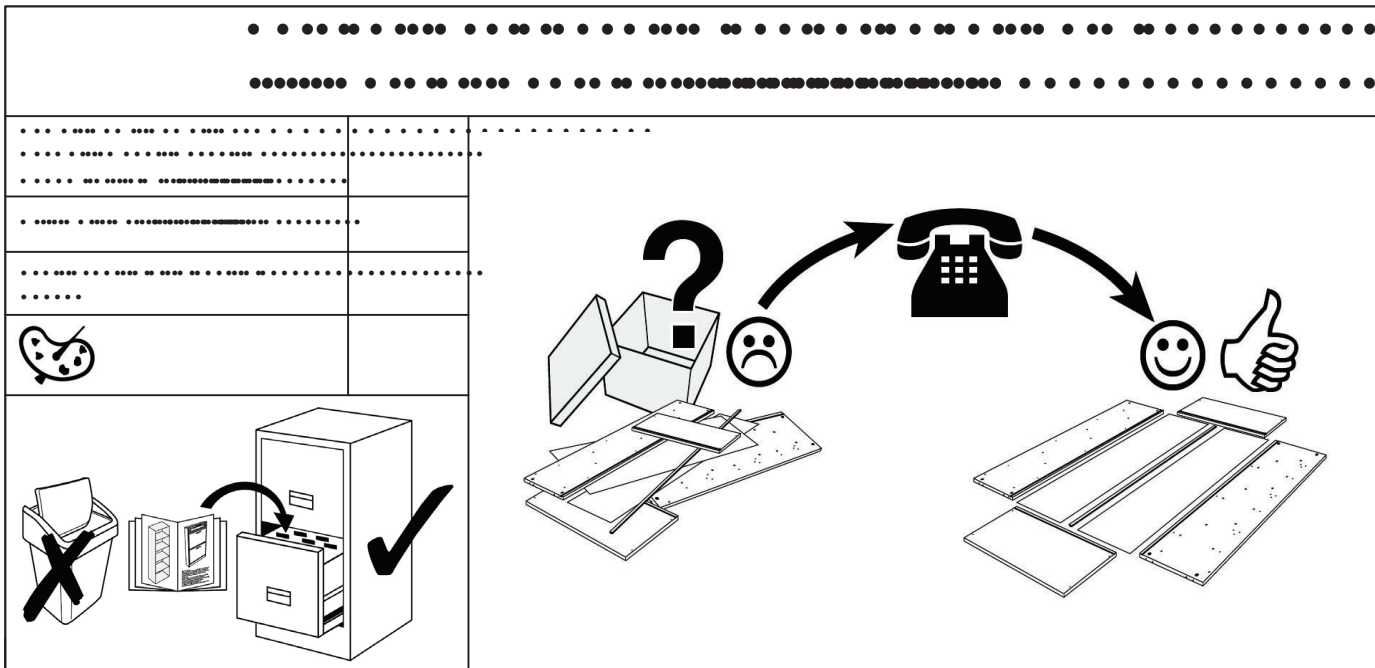

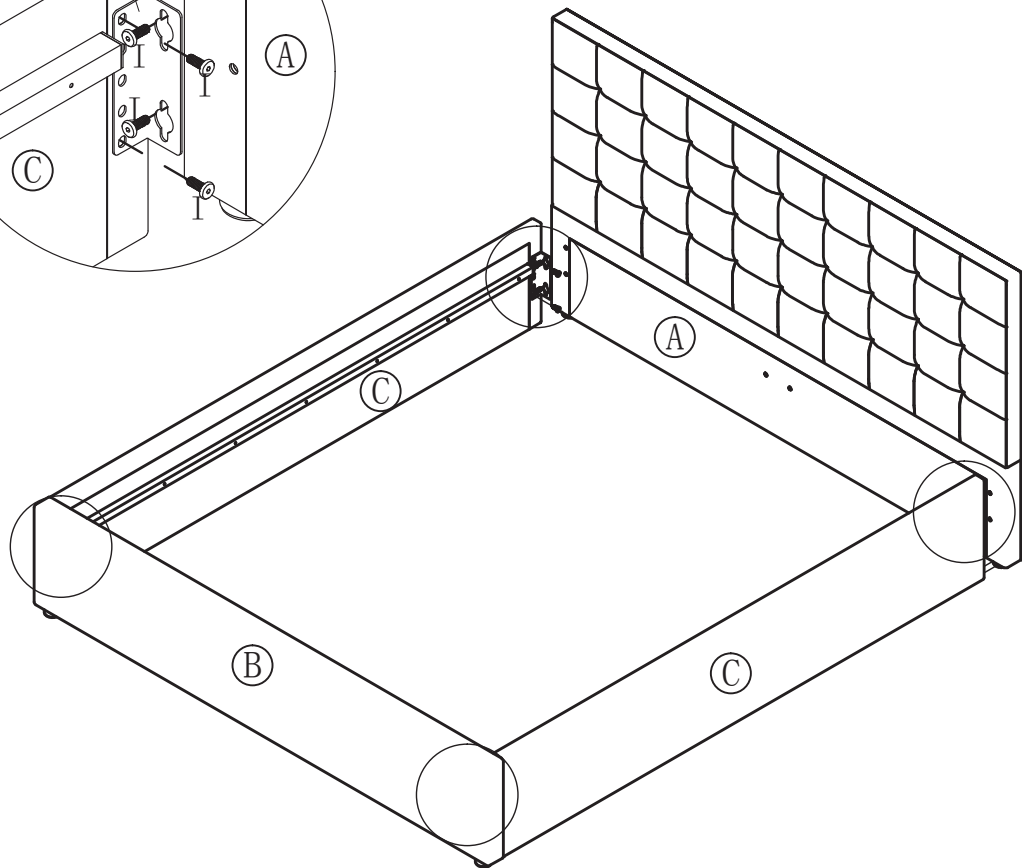
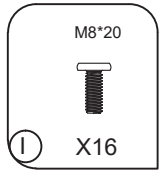
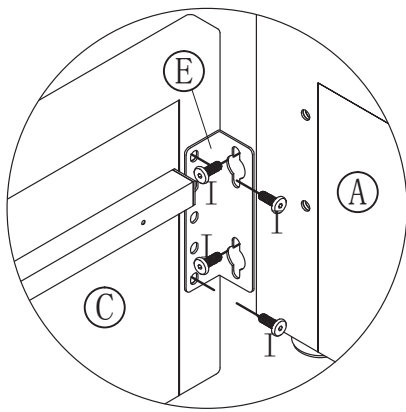
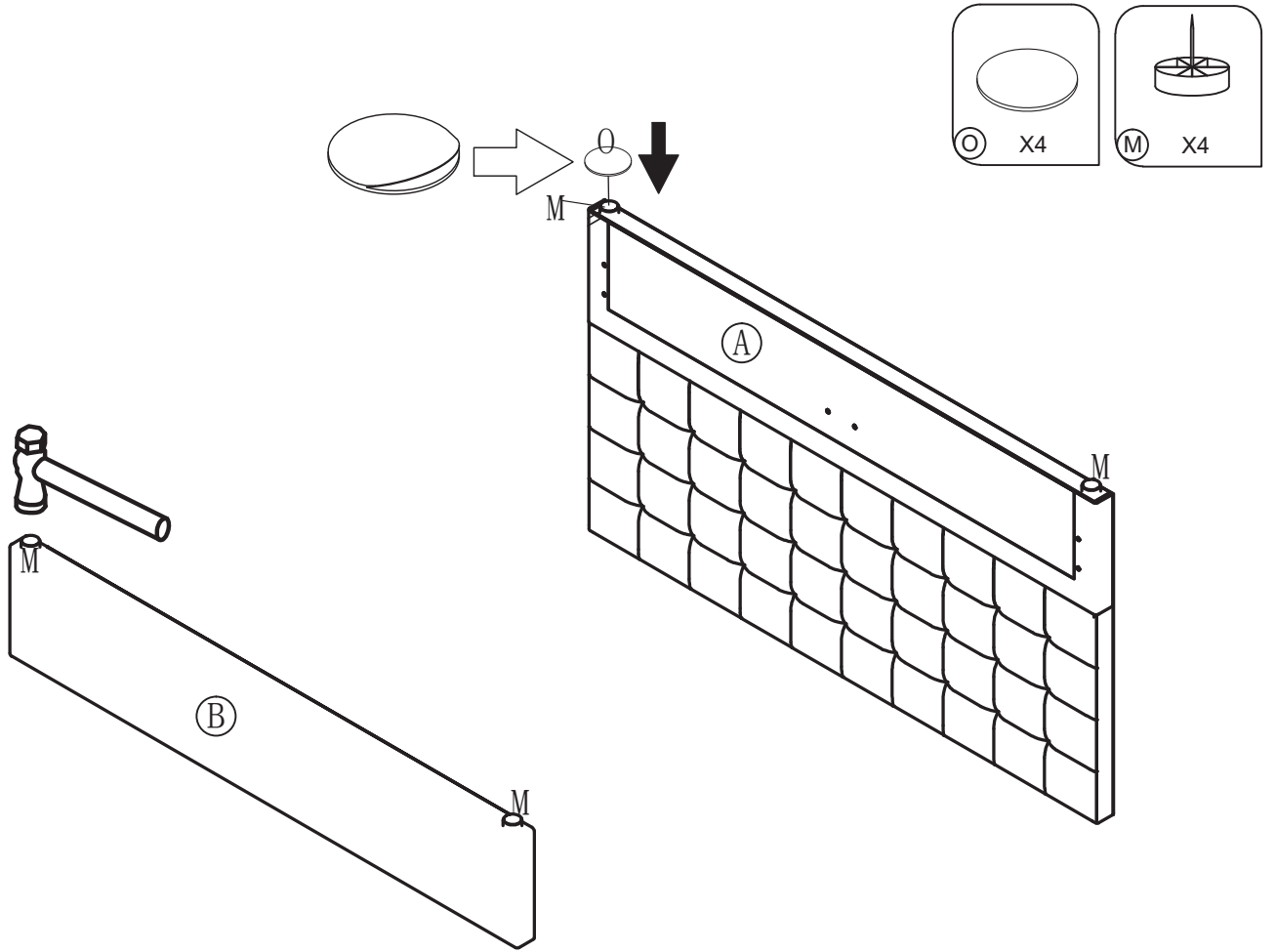

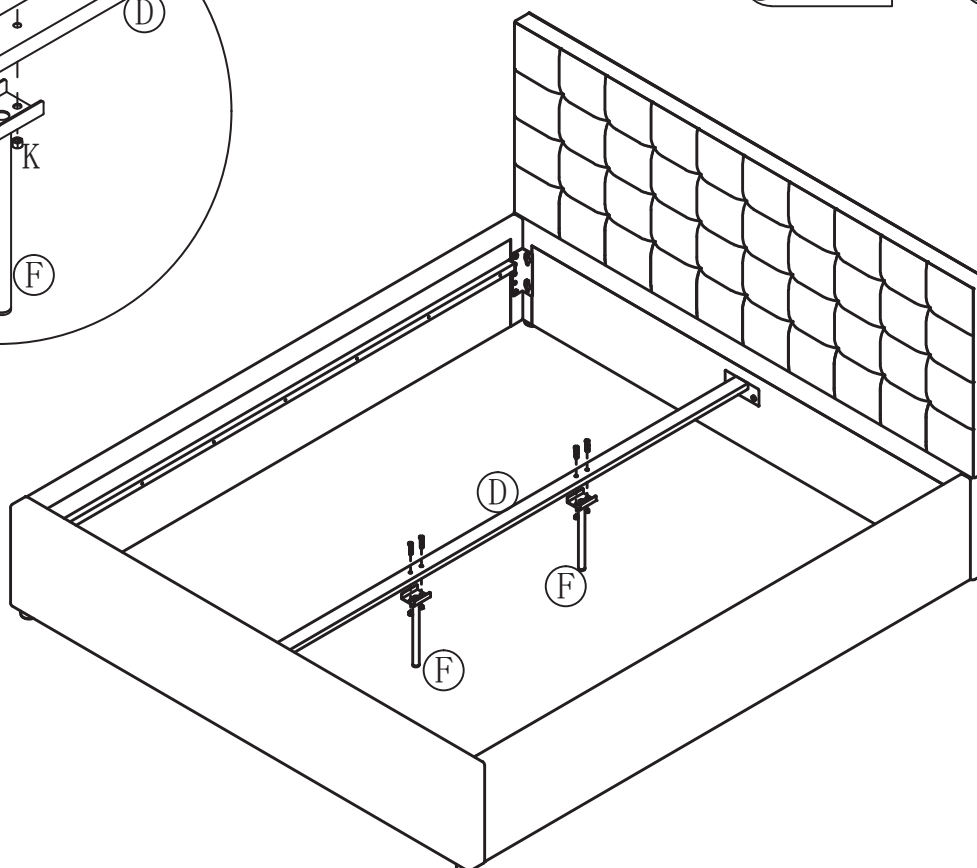
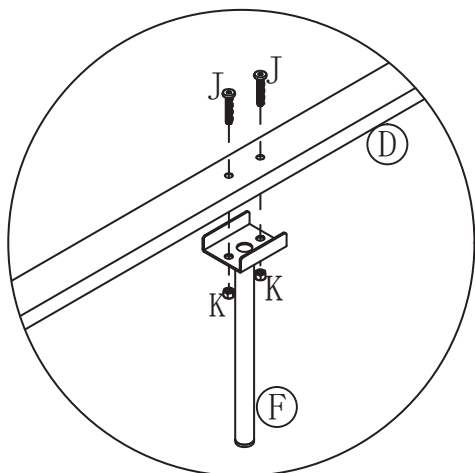
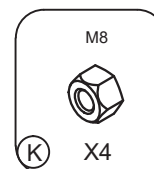
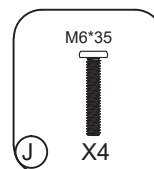
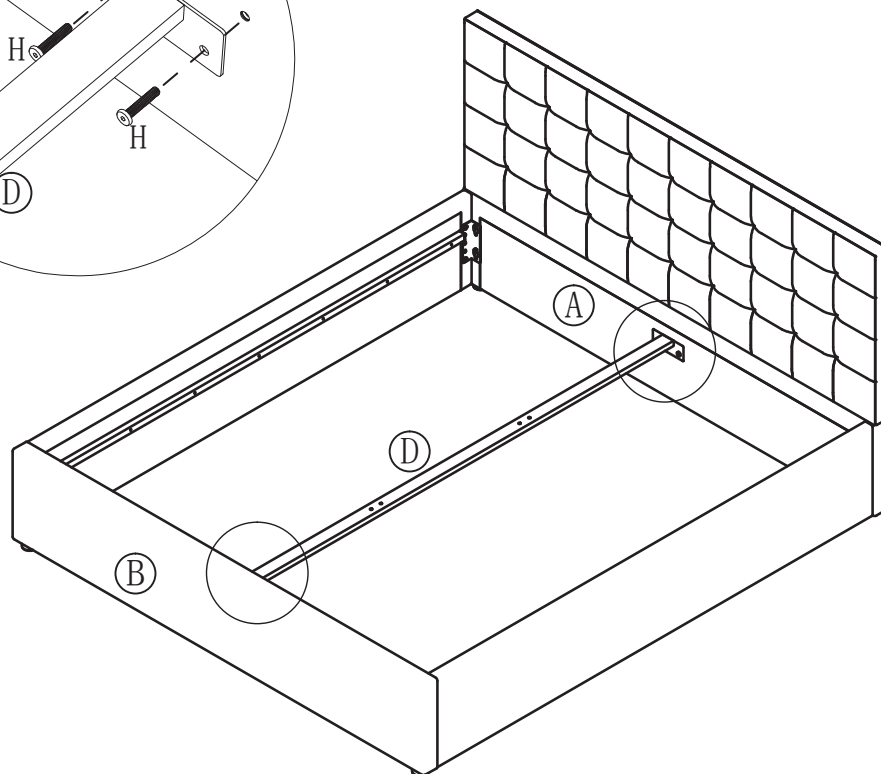
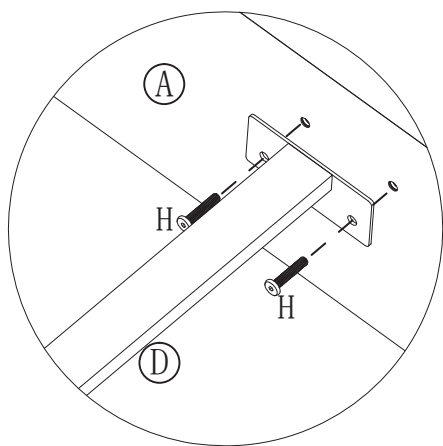
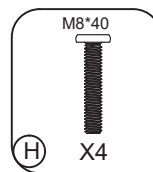

1	D	Ziehen Sie alle Schrauben sowie tragende Verbindungsteile nach ca. 5 Wochen nach, um eine dauerhafte Standsicherheit zu gewährleisten.
	GB	After approx. 5 weeks, tighten all screws and load-bearing connecting parts to ensure permanent stability.
	FR	Resserrez toutes les vis ainsi que les pièces de fixation au bout d'environ 5 semaines pour garantir une sécurité de fixation durable.
	IT	Ristringere tutte le viti e giunture dopo ca. 5 settimane, al fine di garantire una durevole solidità.
	NL	Draai alle schroeven en ook dragende verbindingstukken na ca. 5 weken nog eens vast, zodat een continue stabiliteit wordt gegarandeerd.
	PL	Prosimy po ok. 5 tygodniach dokręcić wszystkie śruby w elementach łączących. Zagwarantuje to Państwu trwałość i stabilność połączeń.
	CZ	Dotáhněte všechny šrouby a nosné spojovací díly p řibližně po 5 týdnech, aby se zaru čila trvalá stabilita.
	SK	Po cca 4 týždňoch dotiahnite skrutky, aby bola zaru čená ich trvalá stabilita.
	HU	Húzza utána - kb. 5 hét múlva - az összes csavart és a teherhordó részeköt ö-alkatrészeket a biztonság érdekében.
	RO	Pentru a asigura o stabilitate de durat ä, strângeți dupä cca. 5 säptämâni toate șuruburile, precum și toate elementele portante de leg äturä.
	TR	Tüm vida ve taşıyıcı bağlantı parçalarını kalıcı bir duruş güvenliğini sağlamak için yaklaşık 5 hafta sonra tekrar sıkınız.
	RU	Подкрутите все болты, а также несущие соединительные детали прибл. через 5 недель для обеспечения устойчивости в течение длительного времени.
	2	D
GB		Please only clean with a duster or a damp cloth. Do not use any abrasive cleaners.
FR		Veillez nettoyer uniquement avec un chiffon à poussière ou un chiffon légèrement humide. Ne pas utiliser de détergent abrasif.
IT		Si raccomanda di pulire solo con un panno per la polvere o uno strofinaccio umido. Non utilizzare detersivi abrasivi.
NL		Reinig alleen met een stofdoek of een lichtjes vochtige doek. Gebruik geen schurende poetsmiddelen.
PL		Czyszczenie nale ży wykonać wyłącznie za pomocą ściereczki lub lekko nawil żonego ręcznika. Nie stosować środków czyszczących do szorowania.
CZ		Čistěte prosím jen prachovkou nebo lehce navlh čeným hadrem. Nepoužívejte drhnoucí čistící prostředky.
SK		Na čistenie používajte len prachovku alebo z ľahka navlh čenú utierku. Nepoužívajte žiadne drhnúce čistiacie prostriedky.
HU		Kérjük, csak portörít ő kend ővel vagy enyhén nedves ronggyal tisztítsa. Ne használjon dörzshatású tisztítószeret.
RO		Vă rugăm să utilizați la curățare exclusiv o cârp ä de șters praful sau o cârp ä ușor umezit ä. Nu utilizați substanțe de curățat abrazive.
TR	Lütfen sadece bir toz bezikle veya hafif nemli yumu şak bir bezle siliniz. A şındırıcı temizlik malzemeleri kullanmayınız.	
RU	Очищайте от пыли тряпкой или слегка влажной ветошью. Не допускается применение чистящих средств, не предназначенных для ухода за мебелью.	

