

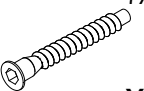





# NR.47

|   |  |  |   |  |  |
|---|--|--|---|--|--|
| <br>S01 7x50<br>x6 | <br>S02 3.5x16<br>x14 | <br>A04<br>x2 | <br>C01<br>x12 | <br>D01<br>x1 | <br>S21<br>x8 |
| <br>B01<br>x2      | <br>SIST. M01<br>x1   | <br>M01<br>x1 | <br>S11<br>x2  |  |  |

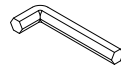
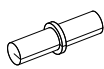
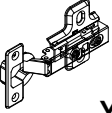
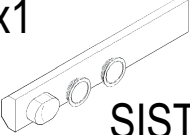

1.

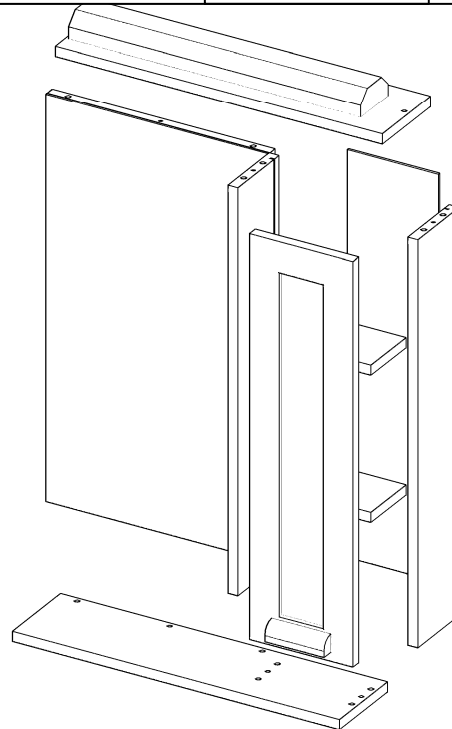
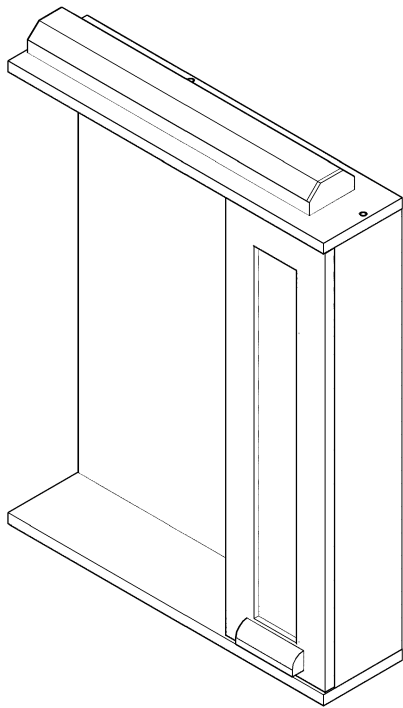
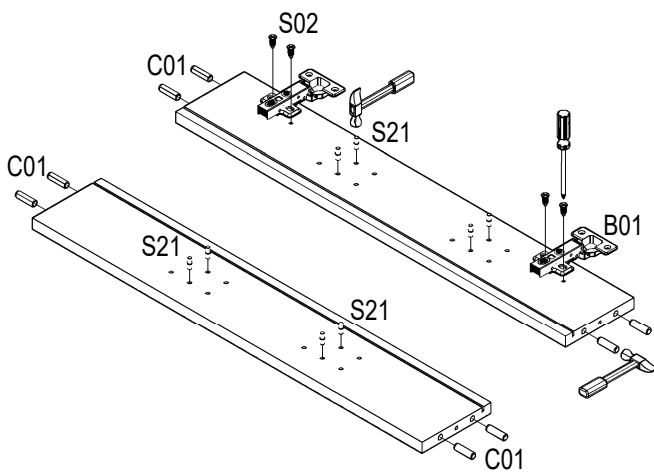

2xB01  
4xS02  
8xC01  
8xS21

2.

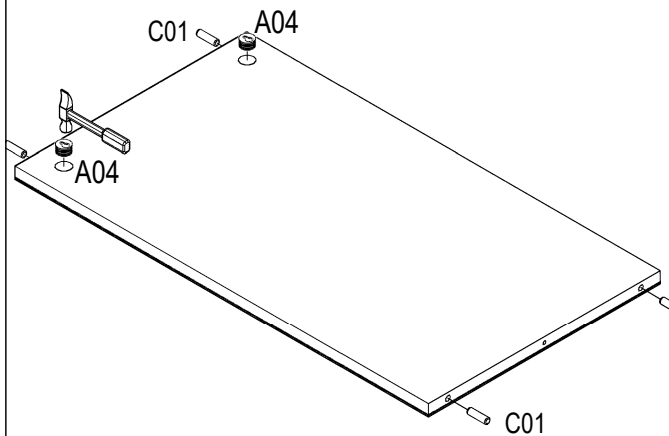

2xA04  
4xC01

3.

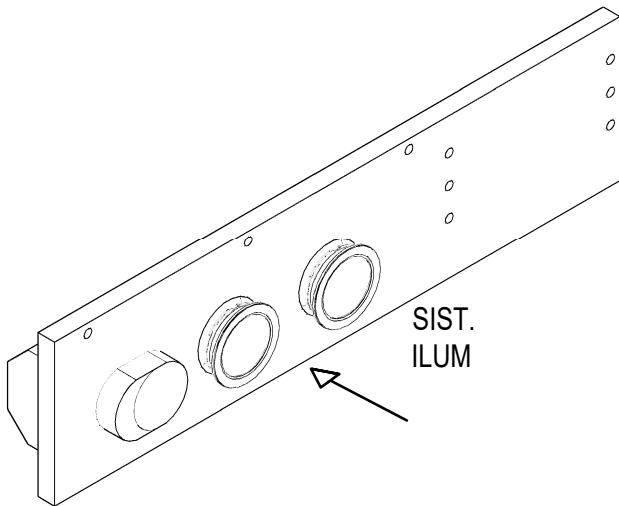

4.

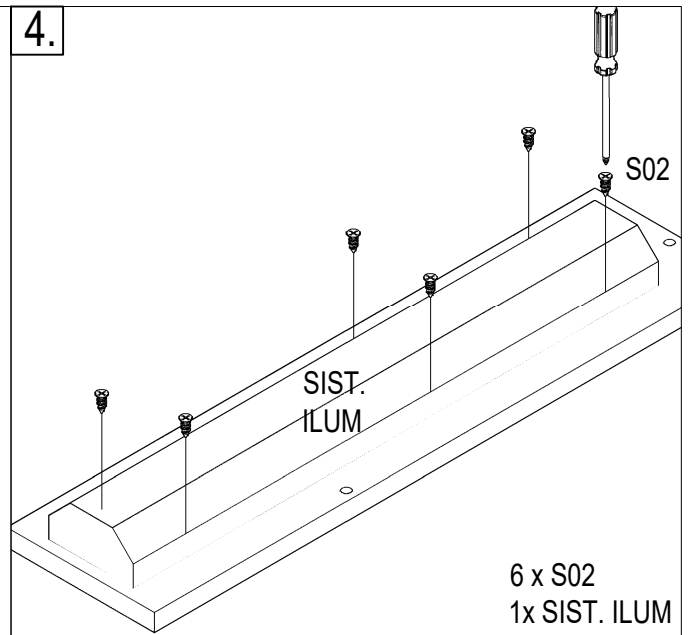

5.

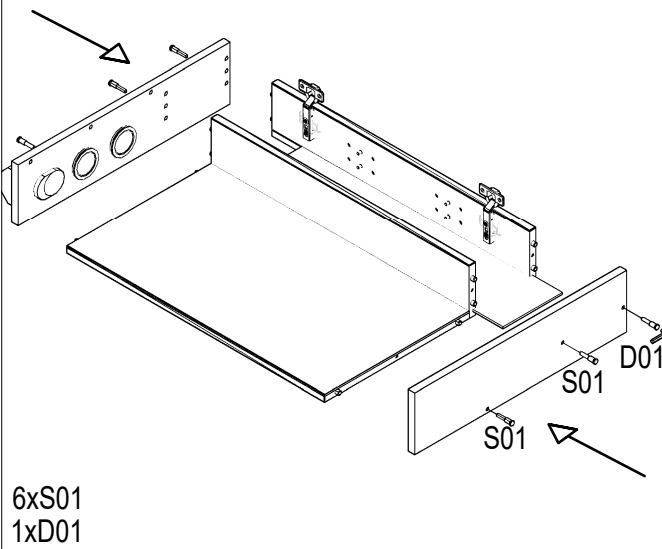

6.

