

5

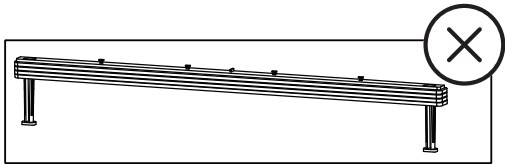

6

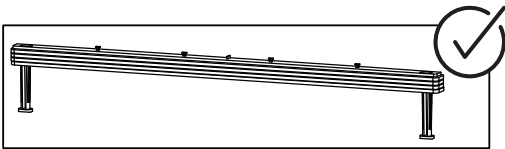
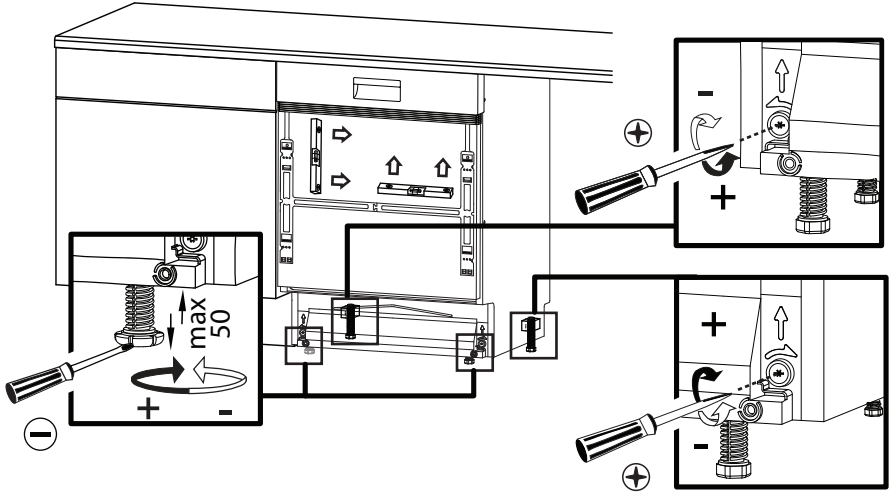
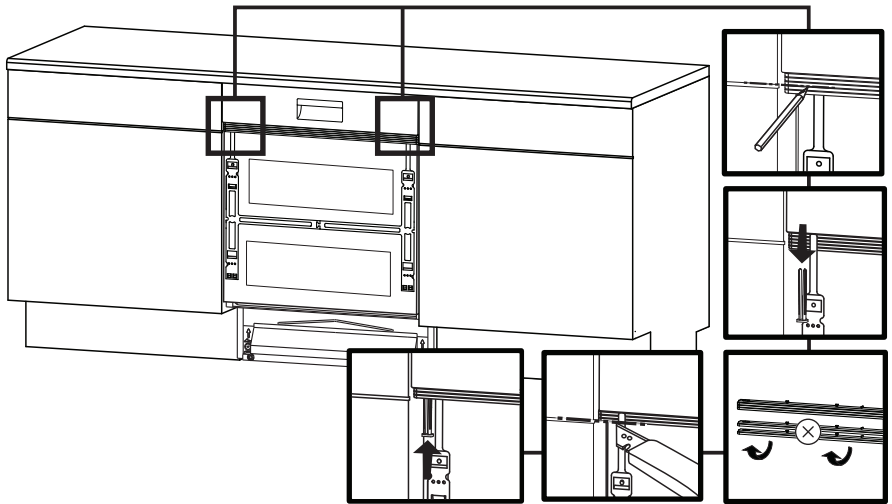

7

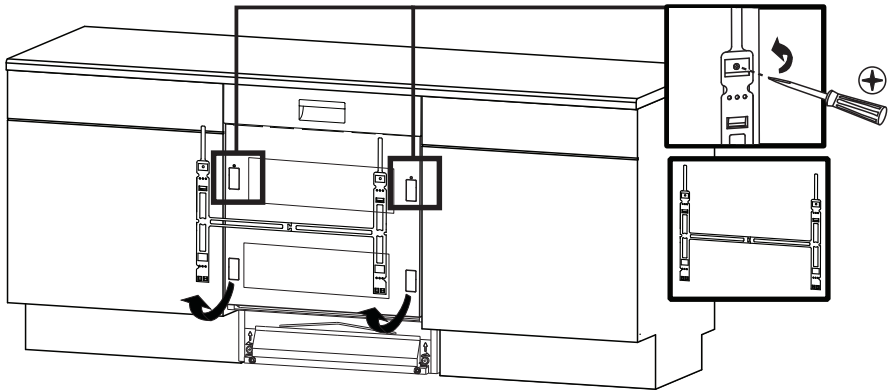

8

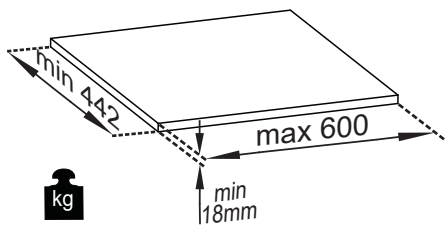

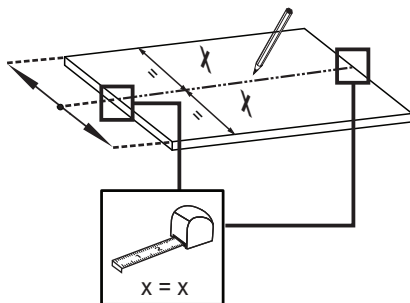

min 2,5 kg
max 5,5 kg

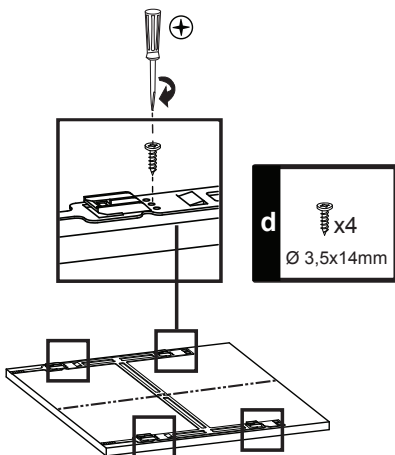
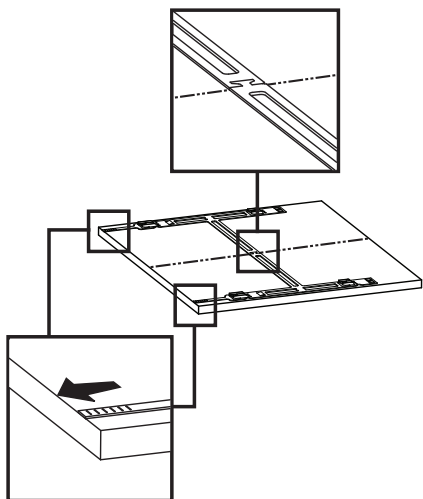

9

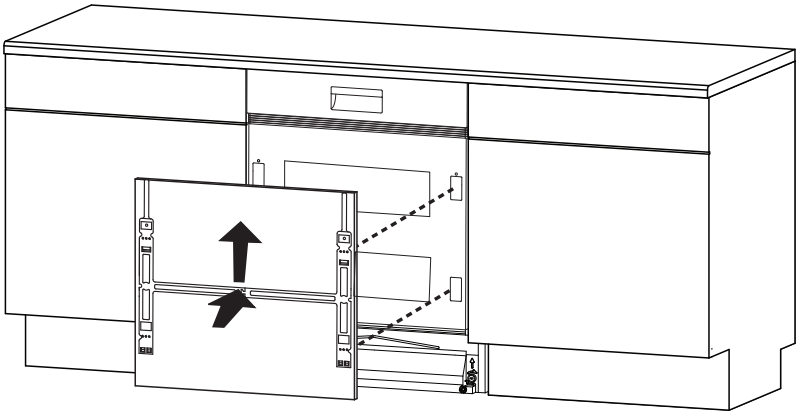

10



11

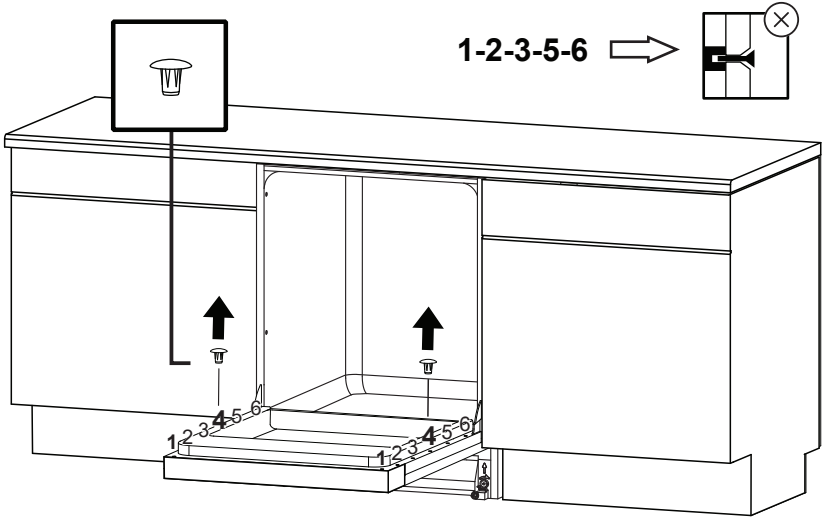

12

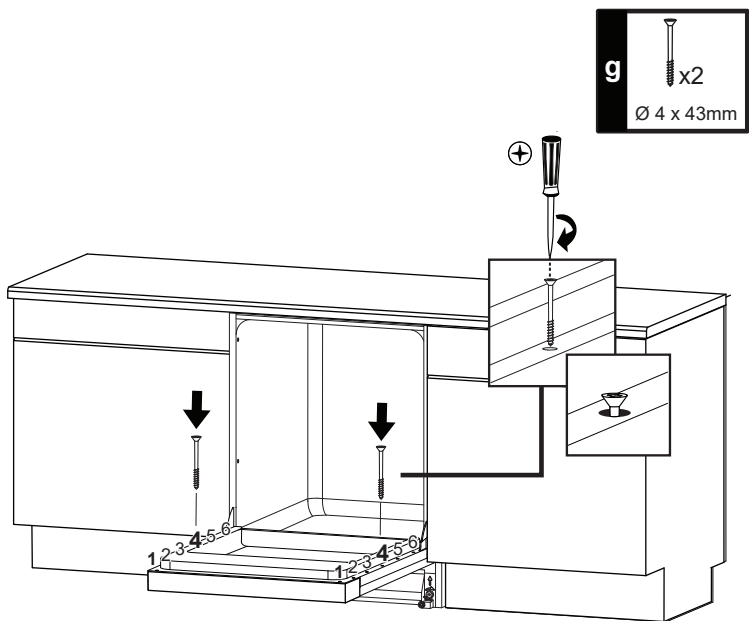

13

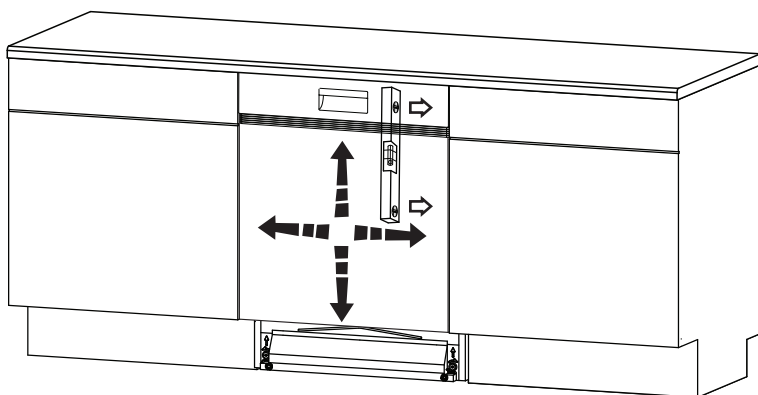

14

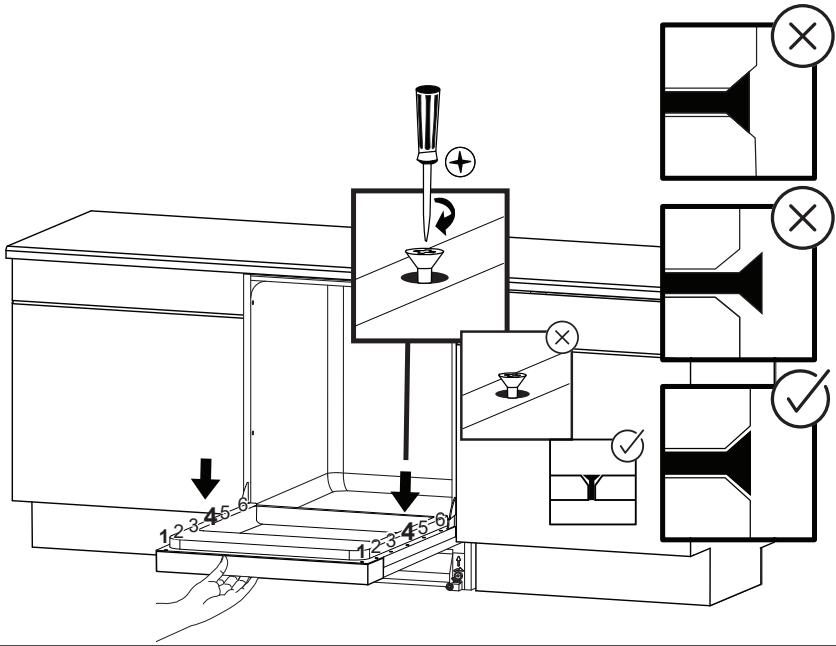

! 15 !

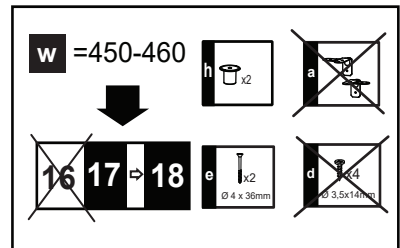
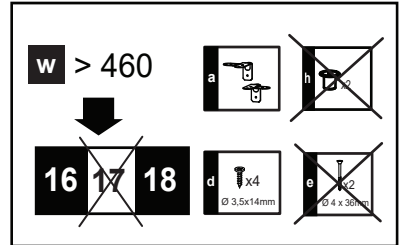
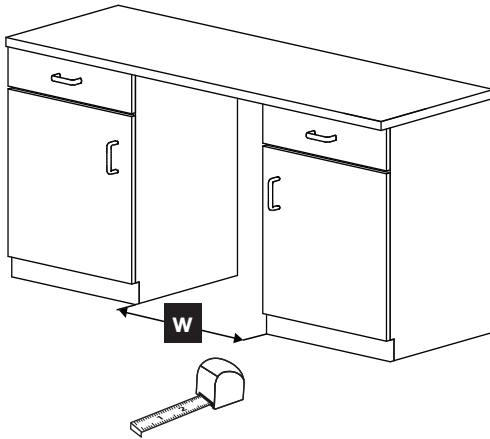

16
—
a

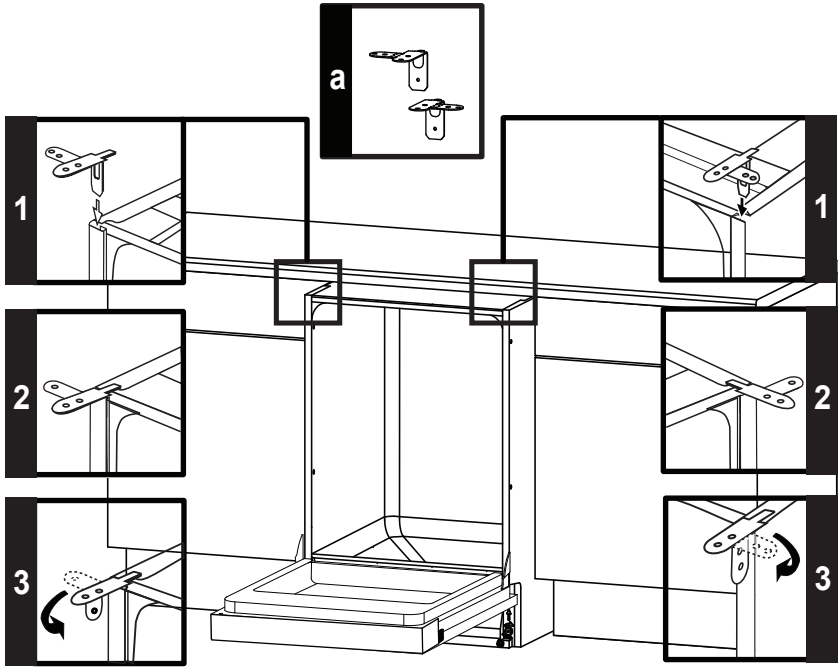

16
—
b

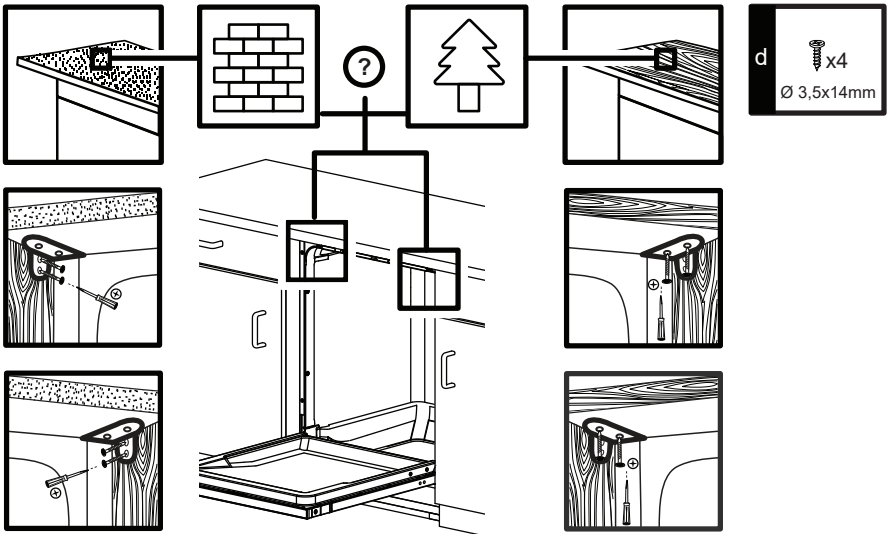

17
—
a

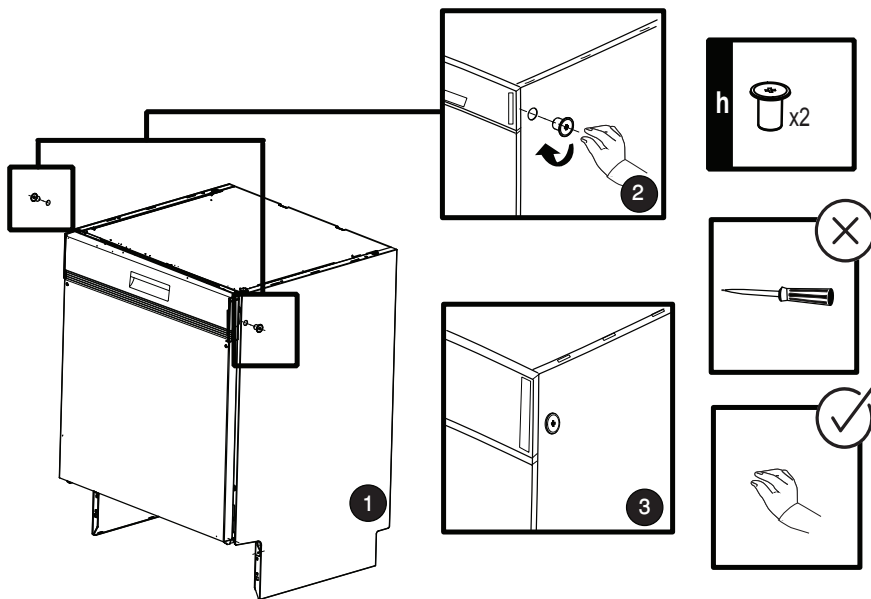

17
—
b

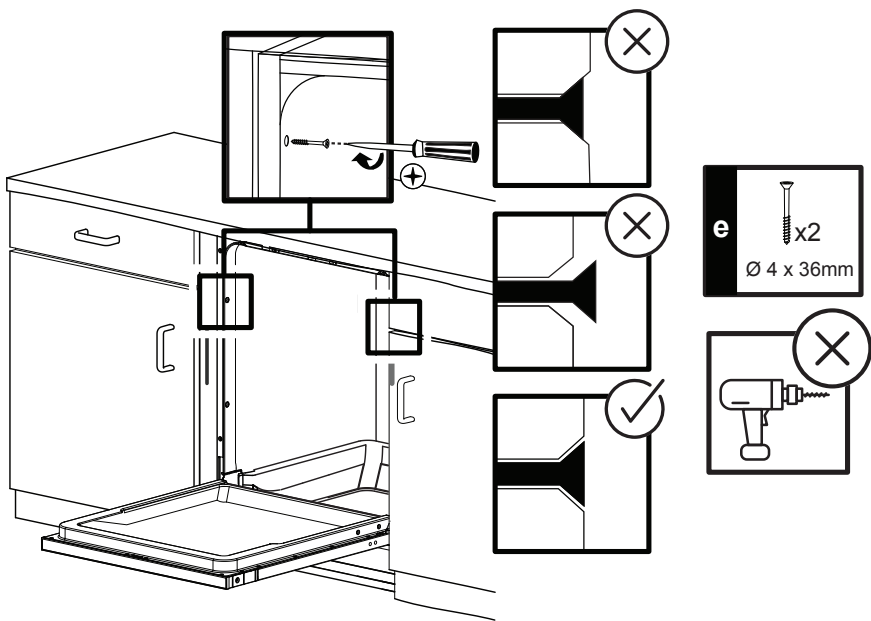

18

