

-45

Montageanweisung / Installation instructions / Instruction de montage / Istruzioni di montaggio
montagehandleiding / Instrukcja montazu / Montaj talimatlar / Osszeszerelési útmutatót / Nàvod k montázi /
Nàvod na montaz / Instructiune de montaj / Инструкция по монтажу / Montaj talimatina / Monteringsanvisningar
Upute za montažu / Instrucciones de Montaje / Navodila za montažo

INFINITY 2.0

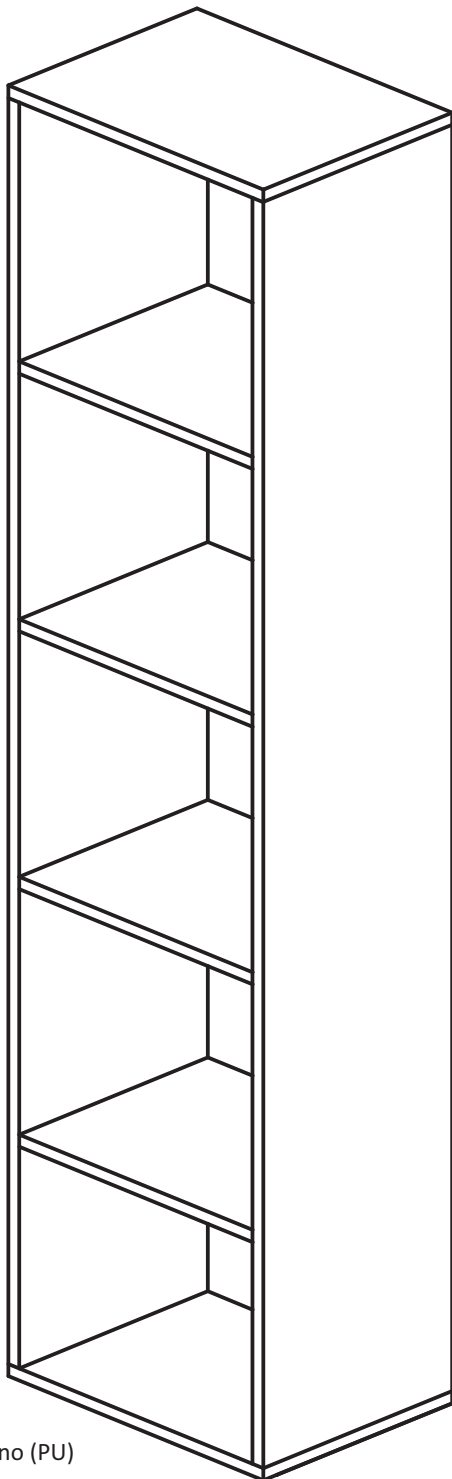
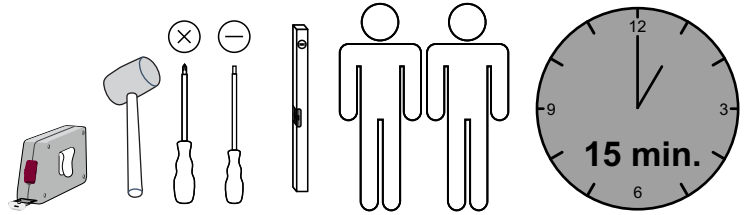

D – bitte lesen sie diese montageanleitung gut durch,
Da wir für fehler, die durch falsche montage entstehen,
Keine haftung übernehmen!

Gb – please read these installation instructions
Through carefully as we cannot accept any liability
For faults occurring as a result of incorrect installation!

Cz – přečtěte si prosím pozorně tento návod k montáži,
Aby jste předešli chybám vzniklých špatnou montáží,
Za které neručíme!

F – veuillez lire attentivement cette notice de montage,
Car nous déclinons toute responsabilité en cas d'erreurs
Découlant d'un montage erroné !

I – prego leggere attentamente le istruzioni per il montaggio,
Poiché decliniamo qualsiasi responsabilità
Per difetti derivanti da montaggio errato.

S - läs monteringsanvisningarna noggrant.
Vi avsåger oss allt ansvar för defekter som
Uppstår p.g.a. Felaktig montering.

Hr – pažljivo pročitajte upute za montažu,
Jer otklanjamo svaku odgovornost za pogreške
Nastale uslijed pogrešne montaže.

Slo – prosimo, da pozorno preberete navodila za montažo,
Saj zavračamo vsakršno odgovornost za napake,
Ki bi nastale zaradi napačne montaže.

Nl – leest u alstublieft deze montagehandleiding goed door,
Voor fouten door verkeerde montage zijn wij niet verantwoordelijk.

Pl – prosze uwaznie zapoznac sie z instrukcja montazu,
Poniewaz nie ponosimy odpowiedzialnosci za niewlasciwy montaz.

HU – Kérjük, olvassa el figyelmesen
ezt az összeszerelési útmutatót,
mert a helytelen összeszerelésből
a dódó hibákért nem vállalunk felelősséget!

SK – Prosíme, dobre prečítajte si tento návod na montáž,
pretože nepreberáme žiadne ručenie za chyby,
ktoré vzniknú na základe chybnej montáže!

RO – Vă rugăm să cititi cu atenție aceste instructiuni
de montaj deoarece nu preluăm garanția pentru defecte
ce apar datorită unui montaj incorect!

RUS – Пожалуйста, внимательно ознакомьтесь ù
с данной инструкцией по монтажу, поскольку мы не
несем ответственности за ошибки, причиной которых
является неправильный монтаж.

TU – İlkonce kullanma klavuzunu iyi okuyun,
yalnis montaj yapasaniz bunun sorumlusu biz degiliz.

ES – Se ruega leer con atención las instrucciones
de montaje debido a que declinamos cualquier
responsabilidad
por defectos derivados de un montaje erróneo.

LC S.p.A
Via del Piano s.n
61030 Isola del Piano (PU)
Italia
<http://www.lcmobili.com/>

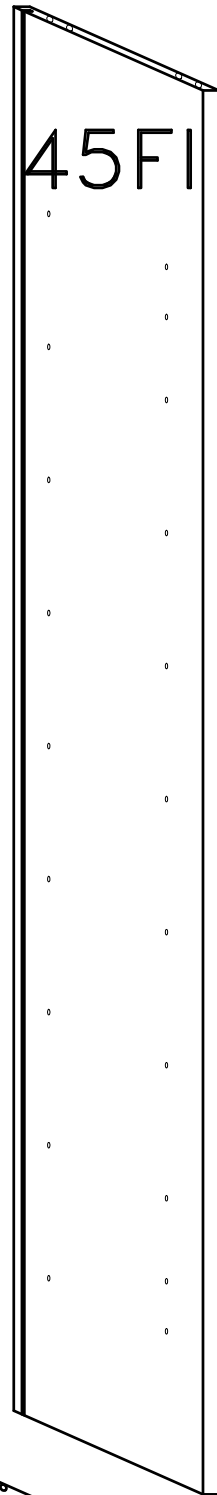
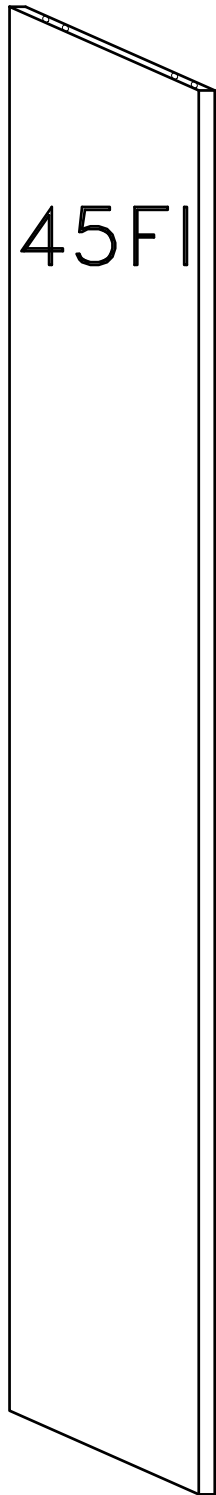
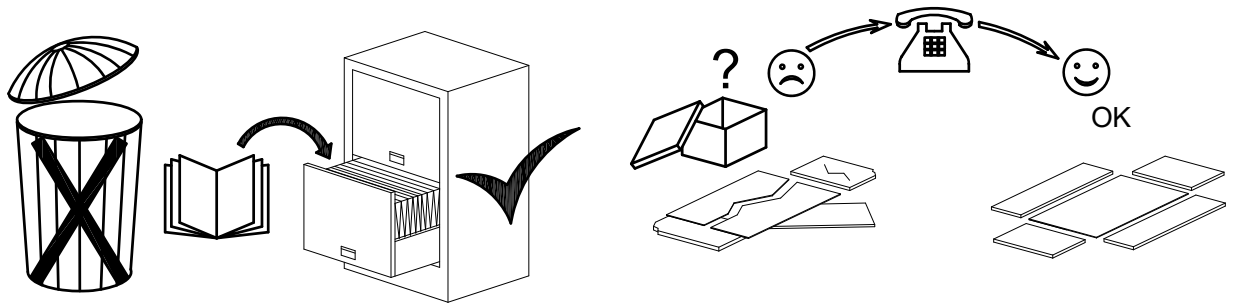

45T0x2

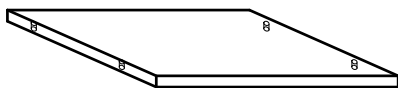
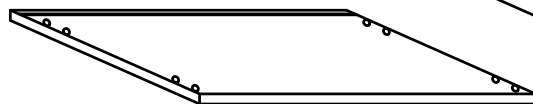

45RI x4

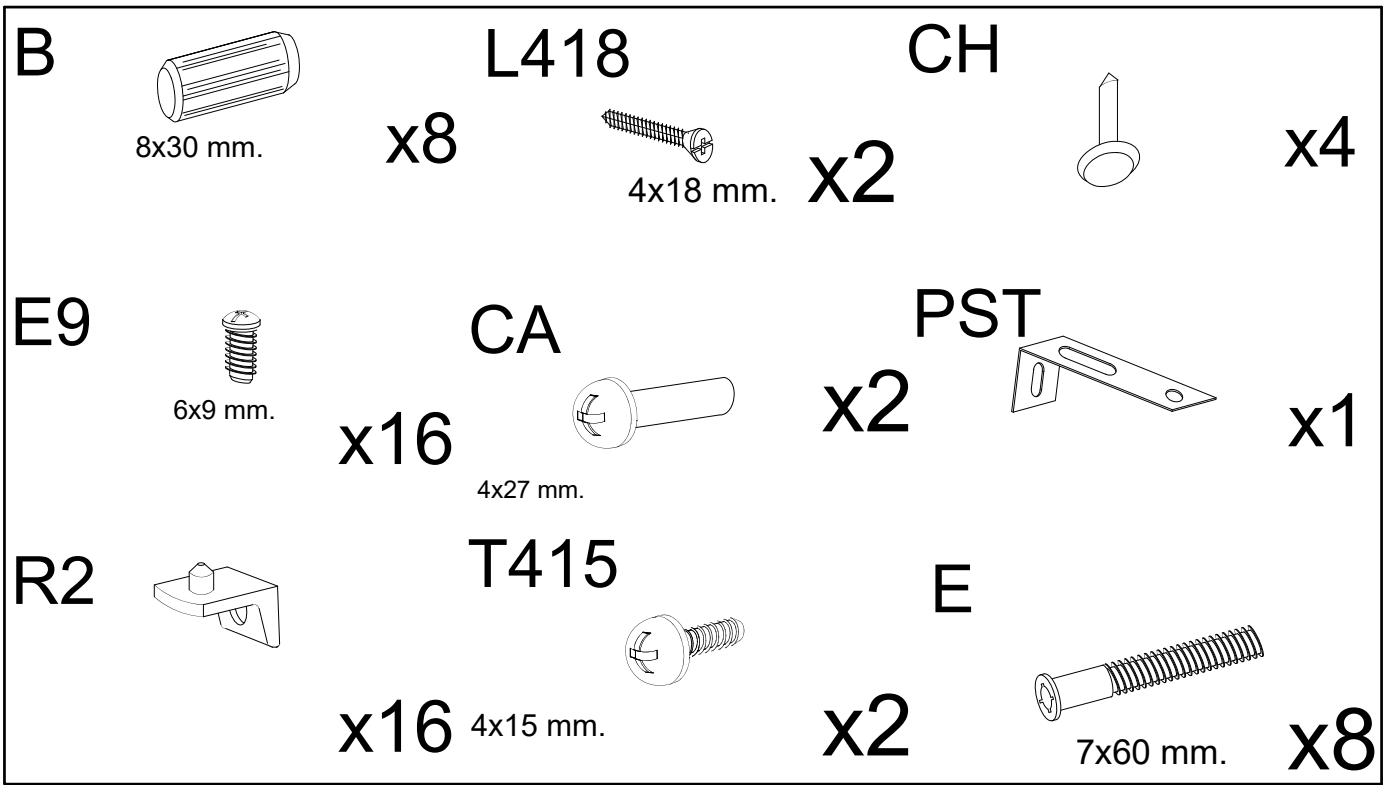

1

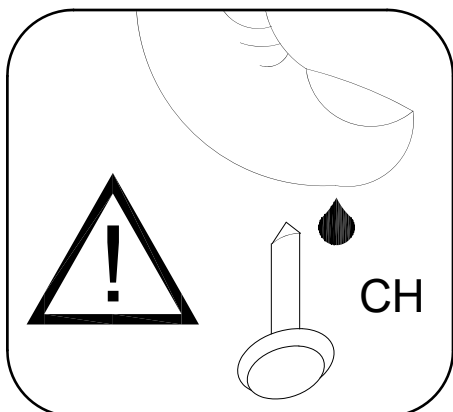

2

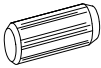
B  8x30 mm. x8

E9  6x9 mm. x16

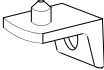
R2  x16

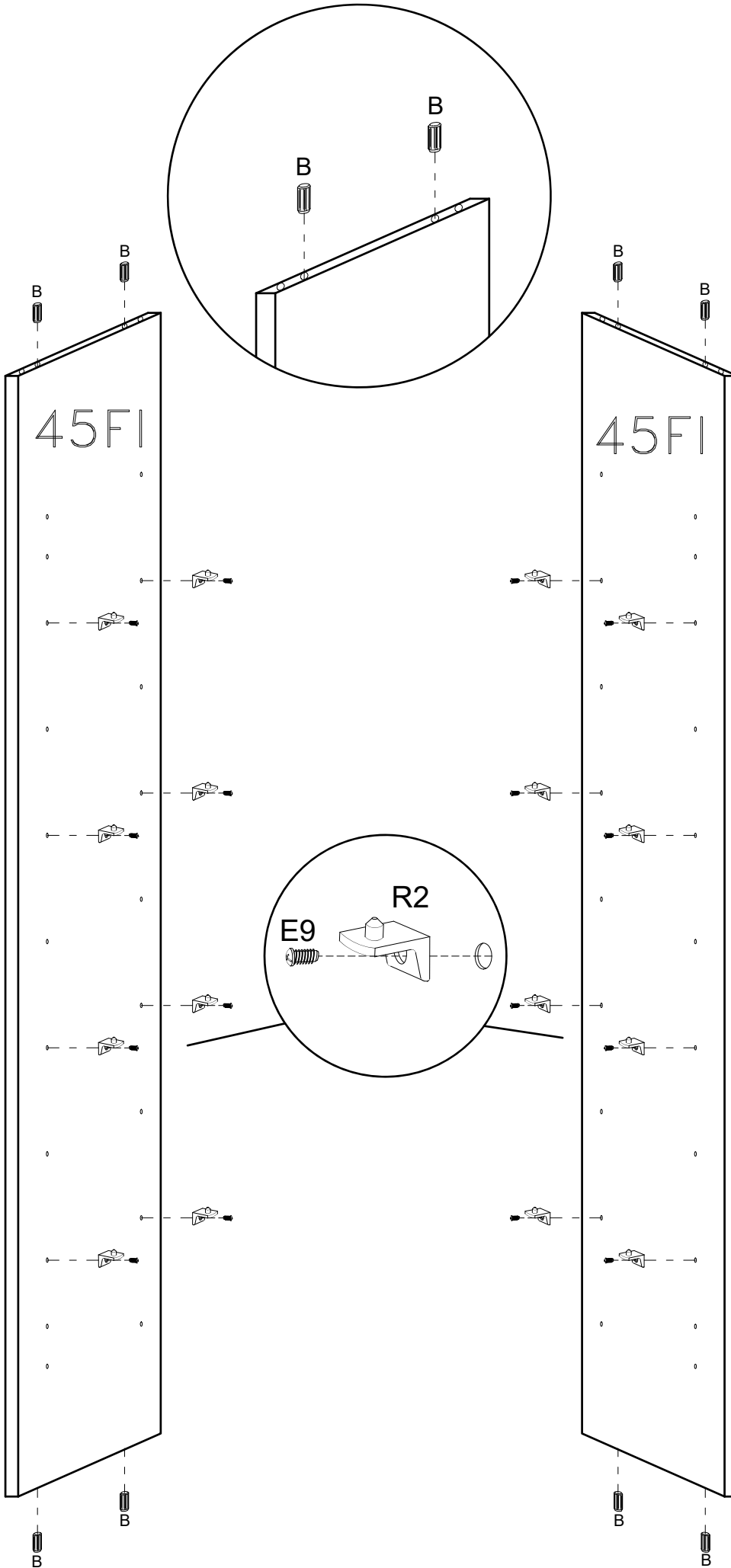

3

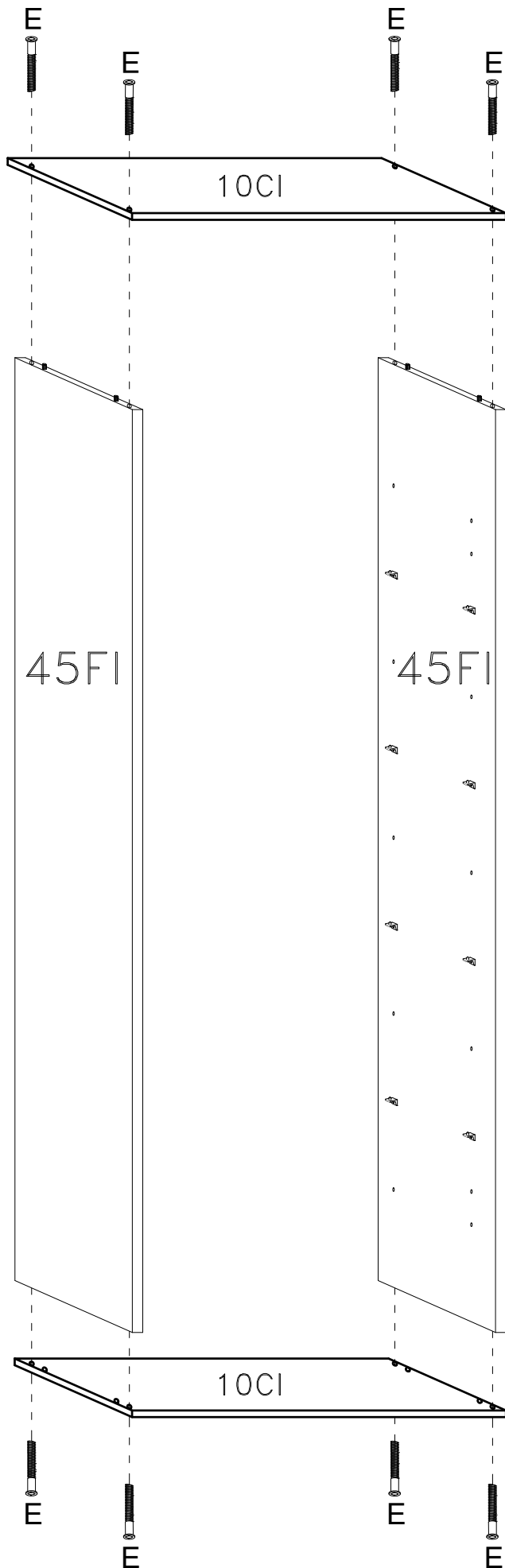

E

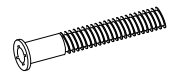

7x60 mm.

x8

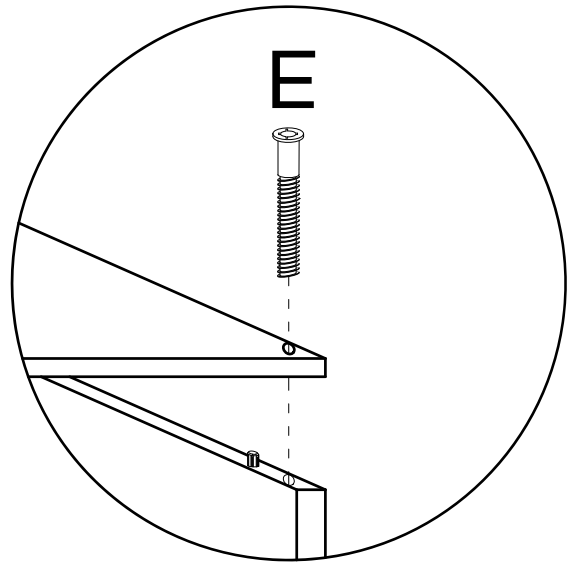

4

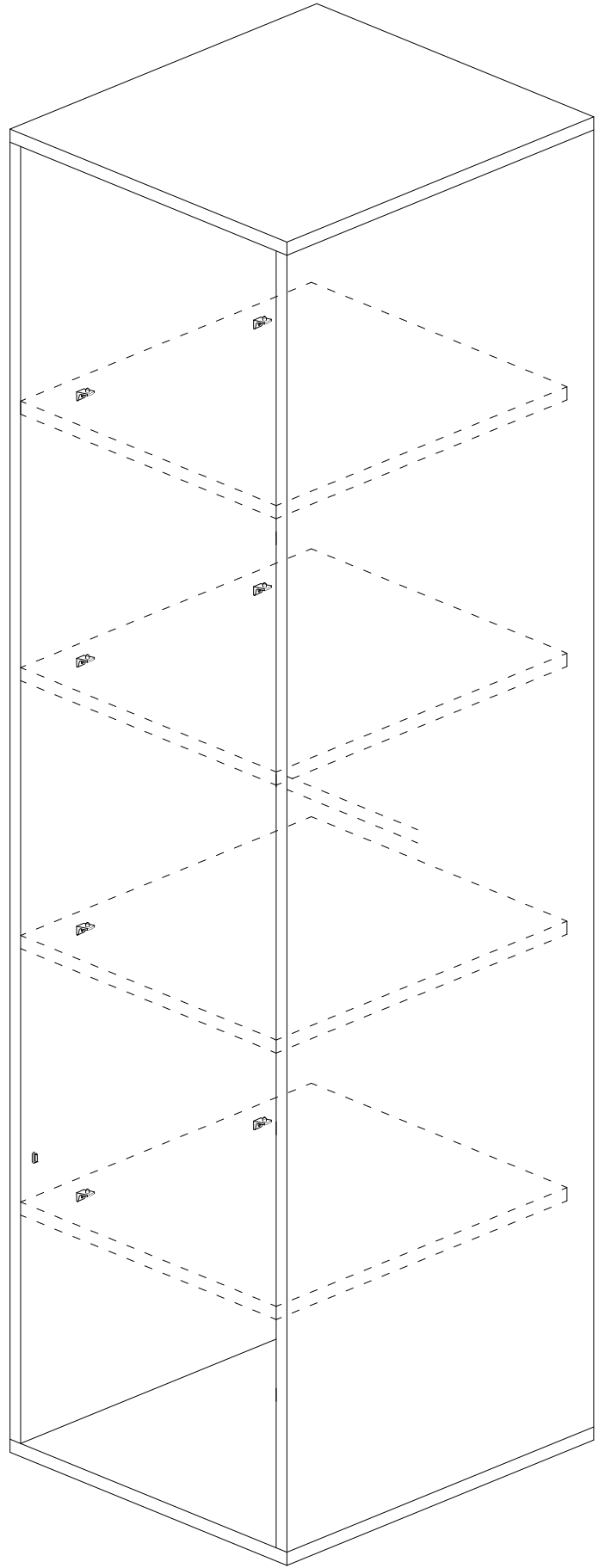
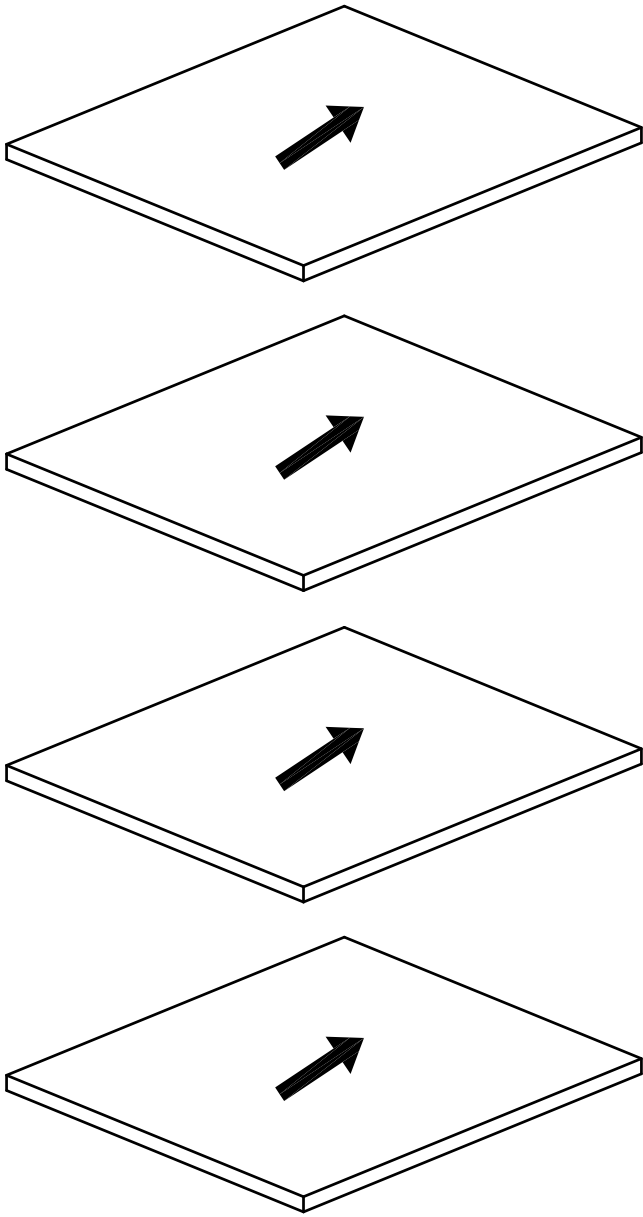

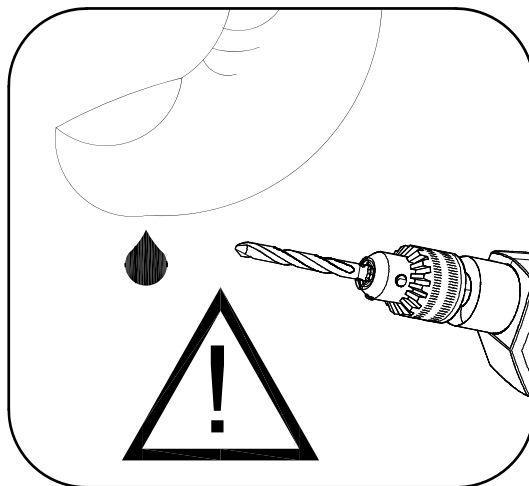
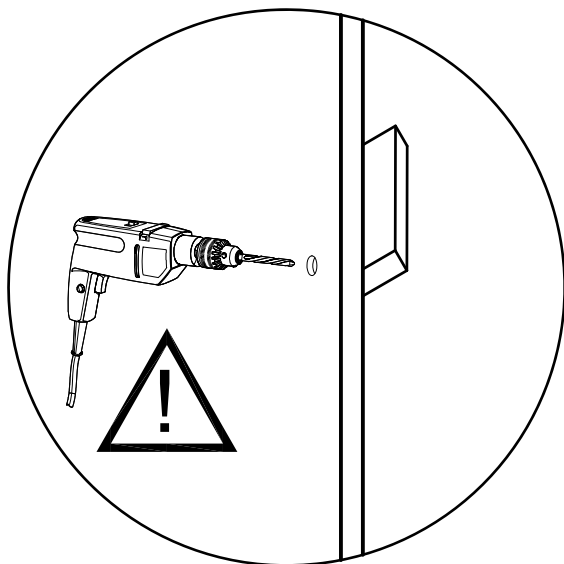
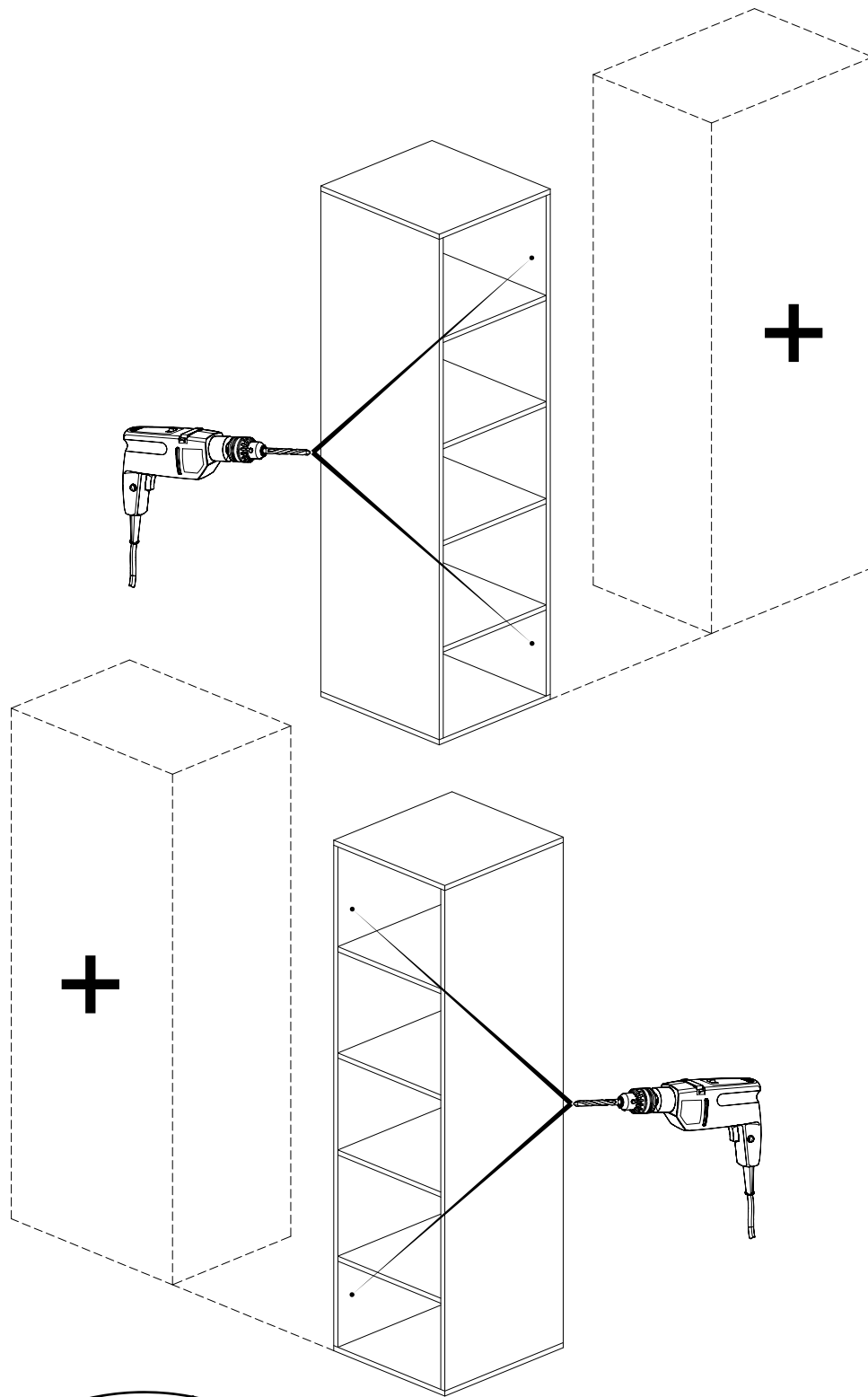

CA

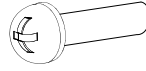

4x27 mm.

T415

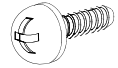

4x15 mm.

x2

x2

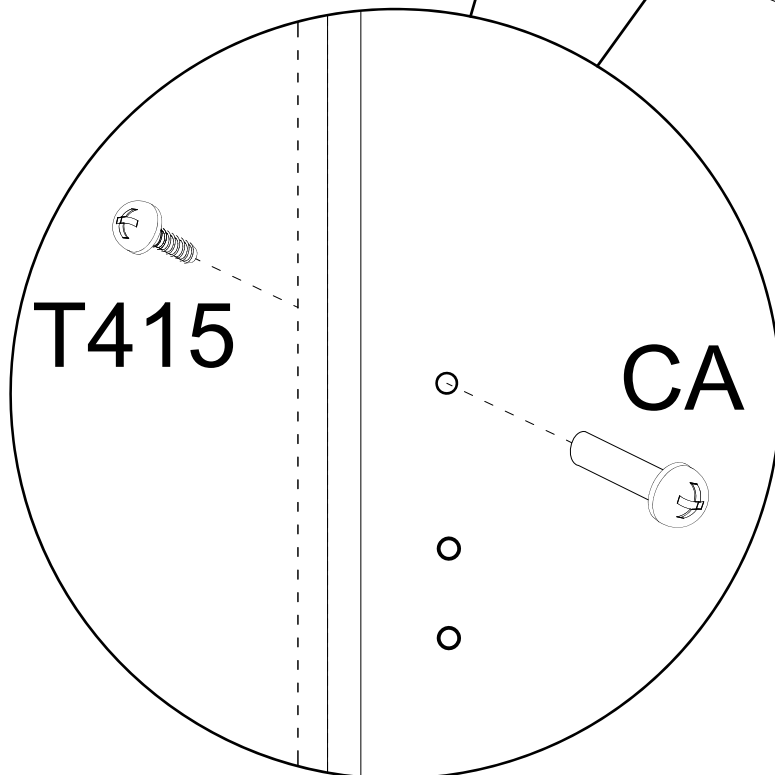
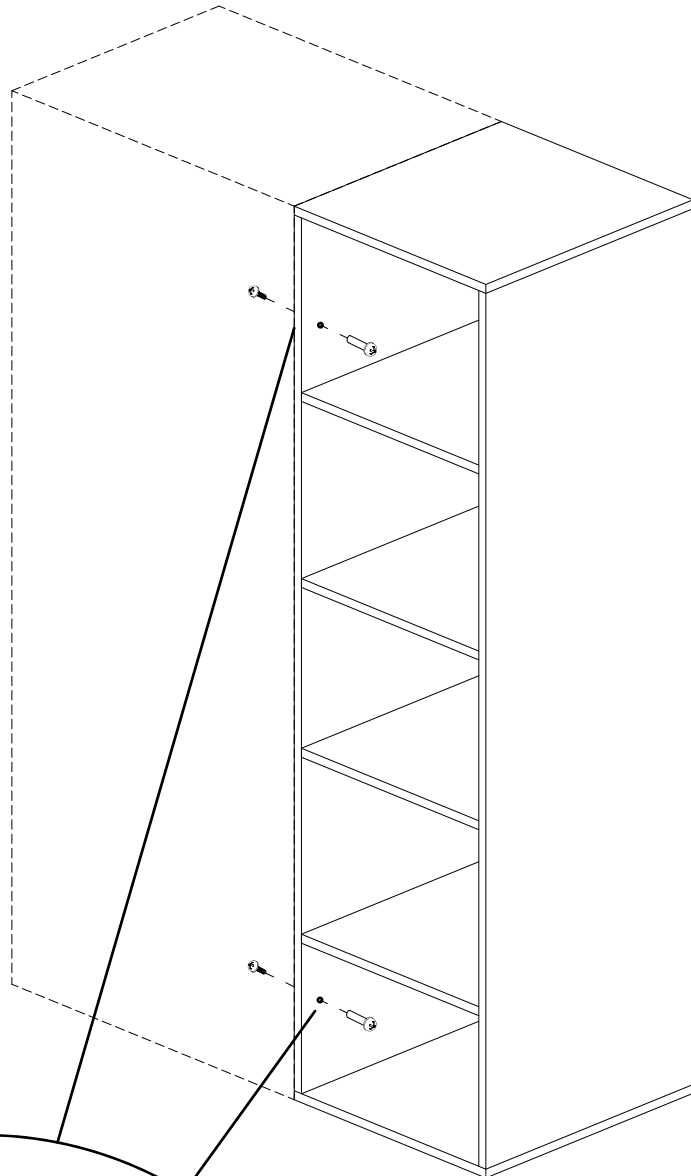

Gentile Cliente

Il montaggio dei pensili deve essere effettuato da personale competente.

I tasselli di fissaggio non sono compresi nella ferramenta.

Scegliere il tipo di tassello per il fissaggio più adatto alla tipologia di muro. Assicurarsi l'idoneità della parete per un sostegno sicuro del pensile.

Dear Customer,

The assembling of the hanging elements must be done by a competent staff. The wall plugs are not included in the hardware package.

Choose the wall plugs more suitable to the type of the wall. Ensure the suitability of the wall for a secure support of the hanging element.

Sehr geehrter Kunde, die Montage der Hängeelemente muss von Fachpersonal ausgeführt werden!

Bitte verwenden Sie eigene Dübel, die der Beschaffenheit der Wand entsprechen. Zu Ihrer eigenen Sicherheit legen wir dem Beschlagbeutel keine Dübel bei.

Cher client, les éléments muraux ne peuvent être installés que par du personnel qualifié !

Veuillez utiliser vos propres ancrages adaptés à la nature du mur. Pour votre sécurité, nous n'incluons pas de chevilles dans le matériel.

Estimado cliente, el montaje de los muebles colgados en la pared debe ser realizado por personal competente. Los tacos de fijación no están incluidos en la bolsa de herrajes. Elija el tipo de anclaje de fijación que mejor se adapte al tipo de pared. Asegúrese de que la pared sea adecuada para un soporte seguro del mueble colgado en la pared.

L418



4x18 mm.

x2

PST

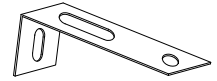

x1

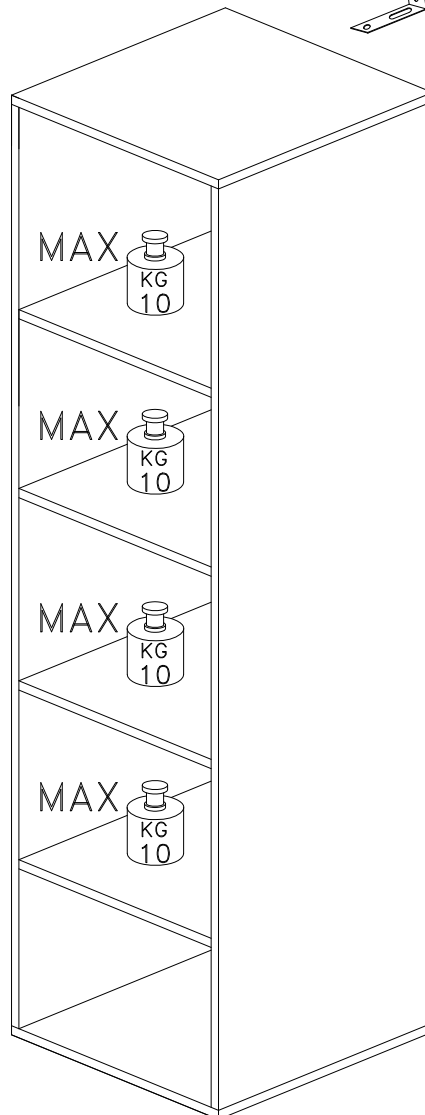
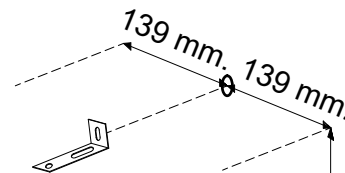
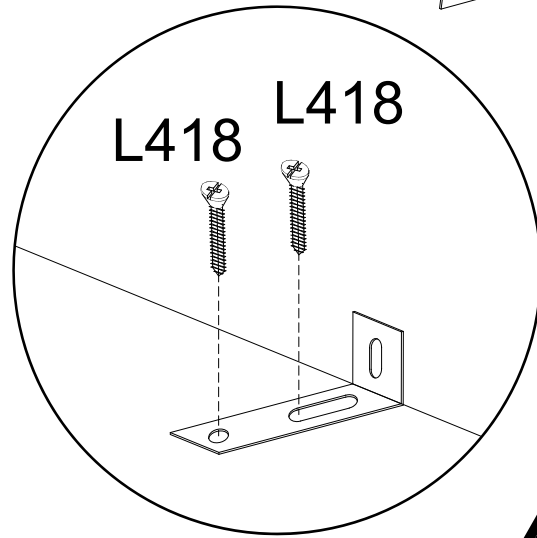

1875 mm.