

Gebrauchsanleitung PK-Nr. 3321
Instructions / Mode d'emploi / Gebruiksaanwijzing /
инструкция по использованию / 使用说明 / Használati utasítás

PAIDI Möbel GmbH
Hauptstraße 87
97840 Hafenlohr
Germany

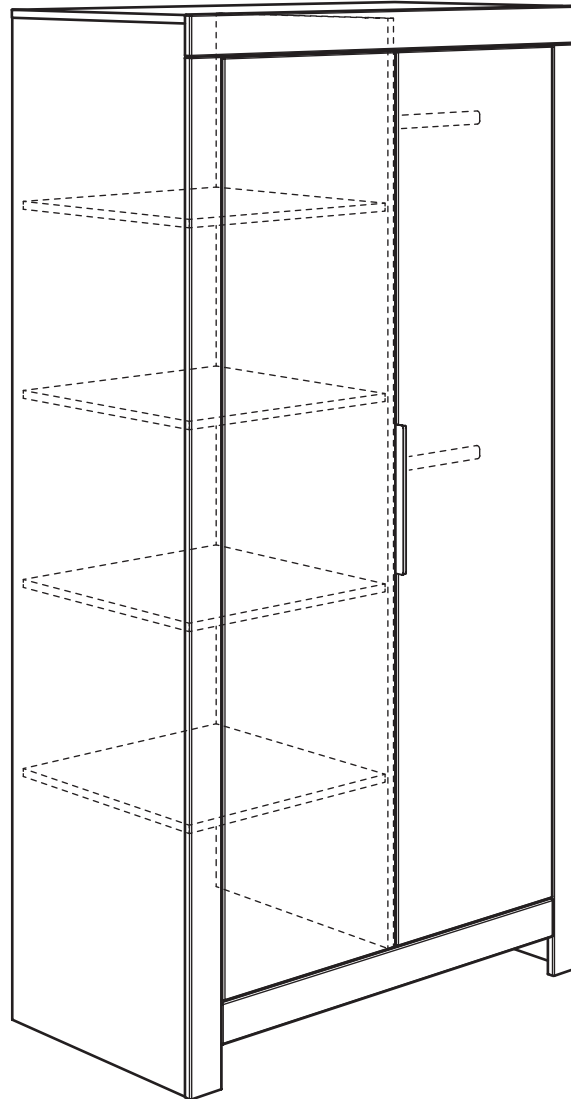

Kinderwelten



JOSIE
163 1144



www.blauer-engel.de/uz38

- emissionsarm
- Holz aus nachhaltiger Forstwirtschaft





Warnhinweis!

Warning! / Avertissement! / Waarschuwing! / Предупреждение! / 警告! / Figyelmeztetés



PAIDI Möbel GmbH
Hauptstraße 87
97840 Hafenhöhr
Germany



Kinderwelten

V..

Vorbereitung / Preparation /
Préparation / Voorbereiding /
Подготовка / 准备 / Előkészítés

M..

Montage / Assembly /
Assemblage / Montage / Монтаж /
组装 / Összeszerelés



PK-Nr. 2800



Warnhinweis!

- DE Warnhinweis! Beiliegende Wandbefestigungen müssen montiert werden!**
- FR** Attention! Les fixations murales ci-jointes doivent être montées!
- GB** Attention! The enclosed wall mountings must be fitted!
- NL** Let op! De meegeleverde wandbevestigingen moeten worden gemonteerd!
- ES** ¡Atención! Las fijaciones murales incluidas deben montarse!
- GR** Προσοχή! Τα εξαρτήματα στήριξης που περιλαμβάνονται στη συσκευασία πρέπει να συναρμολογηθούν!
- IT** Attenzione! Occorre montare i fissaggi per attacco alla parete qui allegati!
- CZ** Pozor! Přiložené úchytky musí být namontovány na stěnu!
- SL** Pozor! Namontirati je potrebno priložene elemente za pritrditev na zid!
- PL** Uwaga! Załączony zamocowania do ściany muszą być zamontowane!
- BG** Внимание! Приложените закрепвания за стена трябва да бъдат монтирани!
- HR** Pozor! Priložena zidna pričvršćenja moraju biti montirana!
- LT** Dėmesio! Pridedamas tvirtinimo prie sienos detales reikia sumontuoti!
- RU** Внимание! Обязательно используйте прилагаемые крепления стене!
- CN** 注意! 附带的墙壁安装组件必须安装!
- HU** Figyelem! A mellékelt fall rögzítőket össze kell szerelni!
- AR** تنبيه! لا بد من تركيب الأدوات المرفقة للتثبيت على الحائط!
- DE** **Schraubenverbindungen von Zeit zu Zeit auf ihre Festigkeit prüfen, gegebenenfalls nachziehen, da die Stabilität der Konstruktion sonst nicht gegeben ist.**
- FR** Vérifier les connexions à vis de temps en temps, resserrer celles-ci le cas échéant, car, sinon, la stabilité de la construction ne serait pas assurée.
- GB** Check the tightness of the screw connections from time to time and tighten if necessary, as otherwise the stability of the construction is not assured.
- NL** Schroefverbindingen moeten van tijd tot tijd op hun stevigheid worden gecontroleerd en eventueel worden vastgedraaid, aangezien de stabiliteit van de constructie anders niet verzekerd is.
- ES** Compruebe de vez en cuando la firmeza de las uniones atornilladas y reapriete los tornillos si fuera necesario, pues de lo contrario quedaría afectada la estabilidad de la estructura.
- GR** Πού και πού ελέγχετε τη σταθερότητα των κοχλιωτών συνδέσεων κι εφ' όσον είναι ανάγκη, τις σφίγγετε ξανά, επειδή διαφορετικά δεν είναι η ευστάθεια της κατασκευής δεδομένη.
- IT** Controllare di tanto in tanto la tenuta delle connessioni a viti, all'occorrenza provvedere a serrarle di nuovo, poiché altrimenti non è garantita la stabilità della struttura.
- CZ** Čas od času zkontrolujte pevnost šroubových spojů, případně je dotáhněte, jinak nebude konstrukce stabilní.
- SL** Vijačne zveze od časa do časa preveriti glede na trdnost, po potrebi priviti, saj sicer stabilnost konstrukcije ne bo zagotovljena.
- PL** Połączenia śrubami sprawdzać od czasu do czasu pod kątem ich trwałości, ewentualnie dokręcać, gdyż inaczej konstrukcja nie jest stabilna.
- BG** Контролирайте от време на време дали болтовите съединения са добре завинтени, тъй като в противен случай не може да се гарантира стабилността на конструкцията.
- HR** Spojeve vijaka s vremena na vrijeme provjeriti u svezi čvrstoće, po potrebi stegnuti, jer inače nije zajamčena stabilnost konstrukcije.
- LT** Kartais patikrinkite varžtų jungčių stiprumą, prireikus suvėžkite juos stipriau, nes priešingu atveju konstrukcija nebus stabilii.
- RU** Перепроверяйте время от времени болтовые соединения. Они должны быть плотно затянуты. Это гарантирует стабильность конструкции.
- CN** 请经常的检查连接处的螺丝，如有发现松动请及时锁紧，否则将无法保障其稳定性。
- HU** Időről ellenőrizze a csavarokétekek szorosságát, adott esetben a csavarokat után kell húzni, ellenkező esetben a szerkezet stabilitása nem adott.
- DE** **Pflegehinweis: Zum Reinigen der Oberflächen ein leicht-feuchtes Tuch oder ein handelsübliches Möbelpflegemittel verwenden.**
- FR** Indication sur l'entretien: pour nettoyer les surfaces, utiliser un chiffon légèrement humide ou un nettoyant pour meubles en vente dans le commerce
- GB** Caring for the...: In order to clean the surfaces please use a slightly damp cloth or commercially available furniture care product.
- NL** Verzorgingsanwijzing: Voor het reinigen van de oppervlakken een licht vochtig doek of een gebruikelijk meubelschoonmaakmiddel gebruiken.
- ES** Recomendaciones de cuidado: Para limpiar las superficies del mueble debe usar un trapo humedecido o un producto de limpieza de muebles comercial.
- GR** Οδηγίες περιποίησης: Για το καθάρισμα των επιφανειών να χρησιμοποιείτε ένα ελαφρά υγροποιημένο πανάκι ή λούστρο επίπλων.
- IT** Indicazione per pulizia e cura: Per la pulizia delle superfici utilizzare un panno leggermente umido o un normale prodotto per la cura dei mobili.
- CZ** Pokyny k čištění: Na čištění povrchu použijte pouze navlhčený kousek látky nebo běžný prostředek na ošetřování nábytku.
- SL** Navodilo za nego: Za čiščenje površin uporabljajte malo vlažno čunjo ali trgovsko običajno sredstvo za nego pohištva.
- PL** Wskazówka pielęgnacyjna: do czyszczenia powierzchni stosować lekko wilgotną ściereczkę lub zwykły środek do pielęgnacji mebli.
- BG** Указания за поддържане: Използвайте леко навлажнена кърпа или обикновен препарат за поддържане на мебели, за да почистите повърхностите.
- HR** Upute za njegu: Za čišćenje površina upotrijebiti jednu lako navlaženu krpu i trgovačko uobičajeno sredstvo za njegu namještaja.
- LT** Rekomendacija priežiūrai: Paviršius valykite drėgna pašluoste arba parduotuvėse įsigytomis baldų priežiūros priemonėmis.
- RU** Рекомендации по уходу: для очистки поверхностей используйте слегка влажную тряпку или обычное средство по уходу за мебелью.
- CN** 保养说明: 清洁表面只需用稍微潮湿的布或普通的家具清洁剂即可。
- HU** Ápolás: A felületek tisztításához enyhén nedves ruhát vagy a kereskedelemben kapható bútörápoló terméket használjon.
- AR** إرشاد للعناية: يرجى من أجل تنظيف الأسطح استخدام منديل رطب بعض الشيء أو استخدام إحدى مواد تنظيف الأثاث المتوفرة في الأسواق التجارية.

Beschläge

Fittings / Raccords / Hulpstukken /
Фурнитура / 配件 / Vasalatok

PAIDI Möbel GmbH
Hauptstraße 87
97840 Hafenlohr
Germany











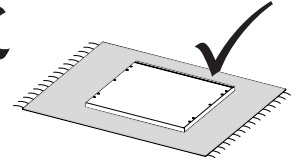
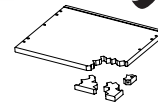
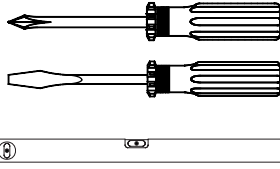
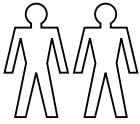



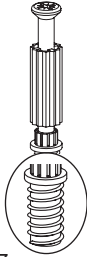

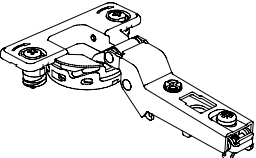
Kinderwelten

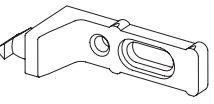
1:1
DIN A4

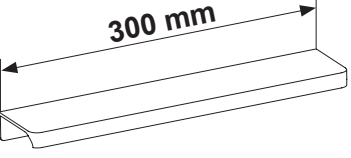
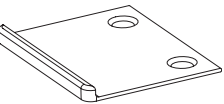

ca. 1,25h



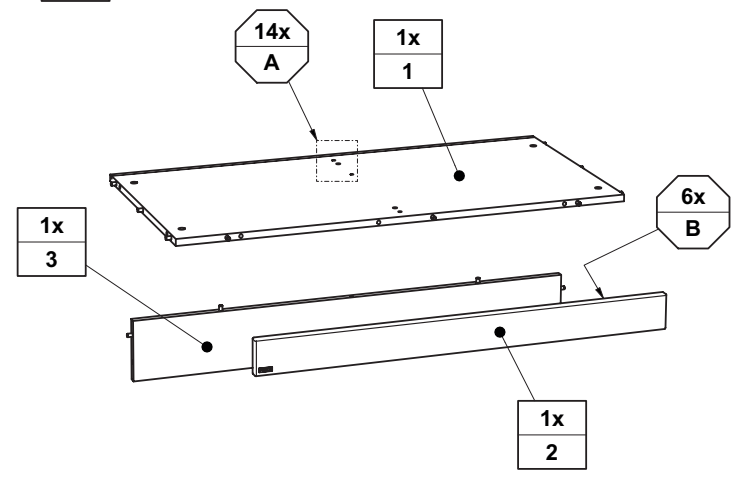
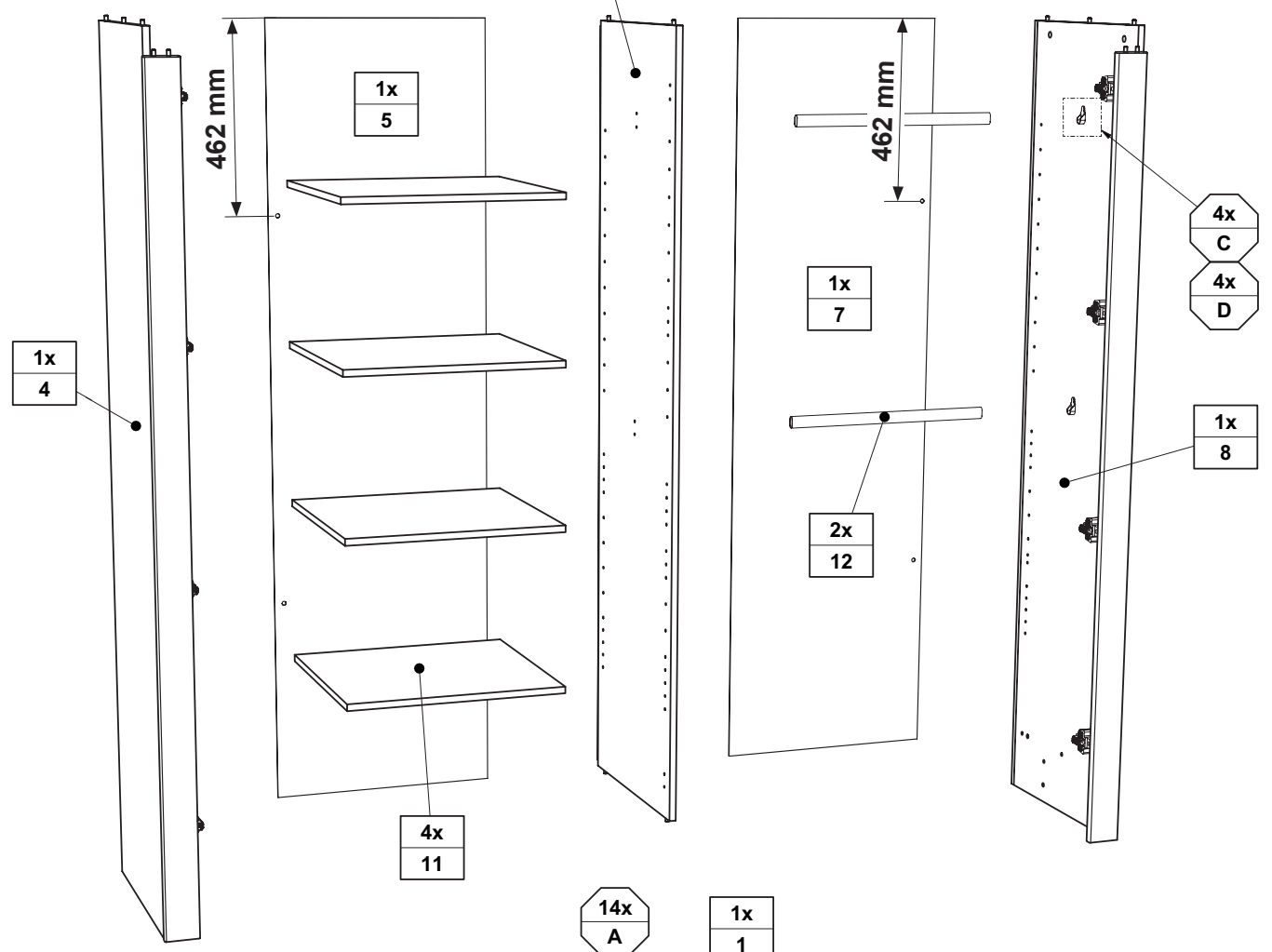
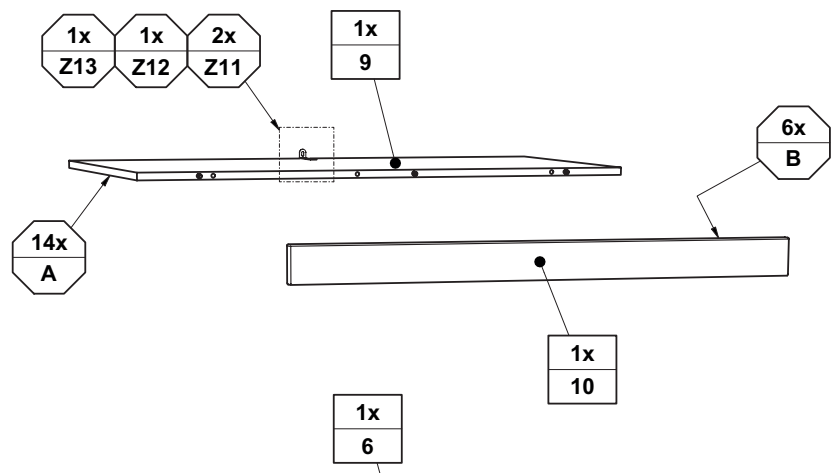

<p>A</p>  <p>14x 681 0759</p>	<p>B</p>  <p>6x 681 0757</p>	<p>C</p>  <p>4x 681 1645</p>	<p>D</p>  <p>3,5 x 13 4x 681 4887</p>	<p>E</p>  <p>8x 681 2794</p>	<p>F</p>  <p>6,3 x 50 1x 681 5311</p>	 <p>SW4 1x 681 3011</p>
<p>G</p>  <p>4x 681 2497</p>	<p>H</p>  <p>6,3 x 15 4x 681 5060</p>	<p>I</p>  <p>300 mm</p> <p>1x 681 8364</p>	<p>J</p>  <p>1x 681 8562</p>	<p>K</p>  <p>6,3 x 11 4x 681 5066</p>		
<p>L</p>  <p>8x 681 2498</p>	<p>M</p>  <p>16x 681 0350</p>	<p>Y</p>  <p>Eiche oak 23x 683 0104</p>	<p>Z</p>  <p>8x 681 2552</p>			

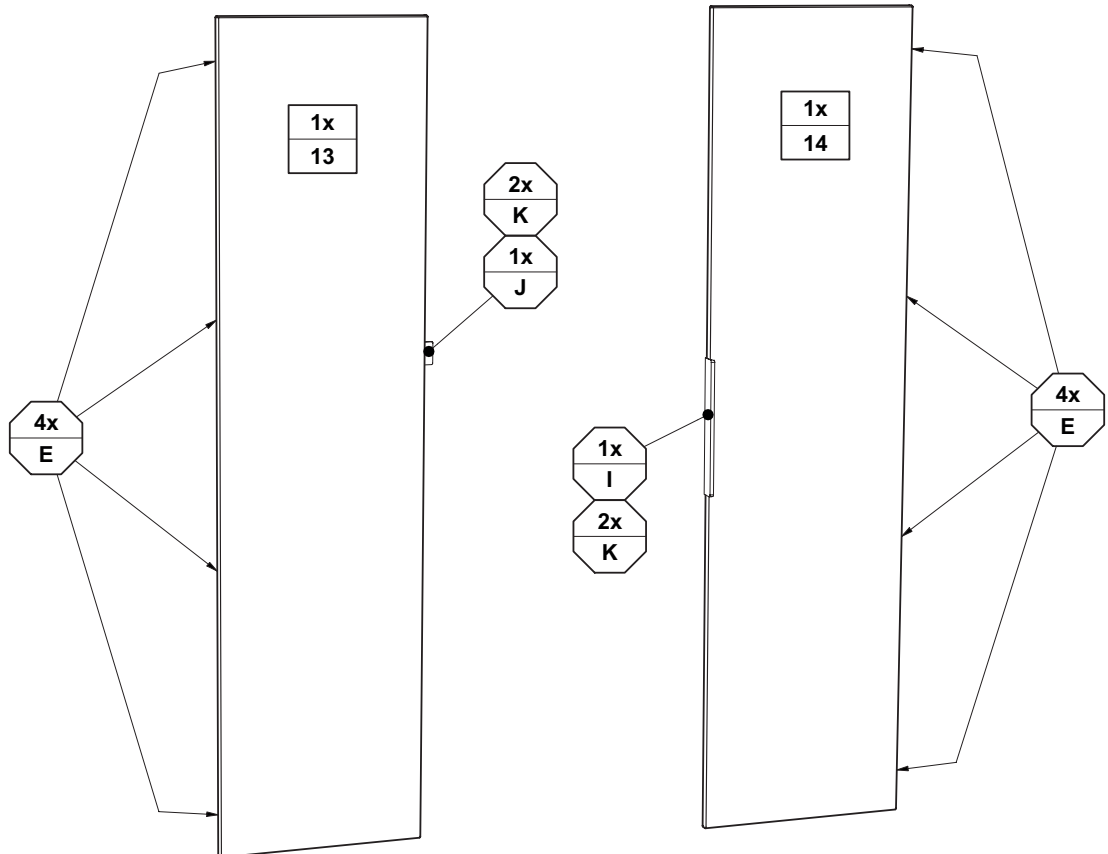



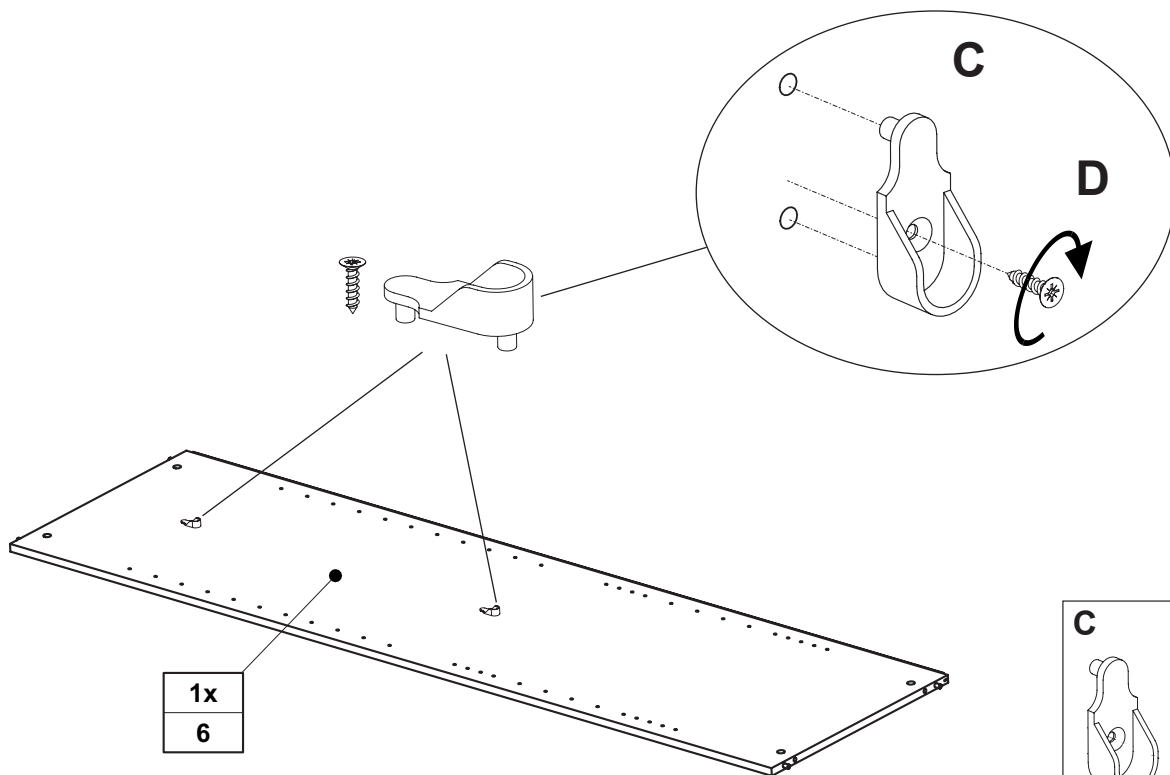
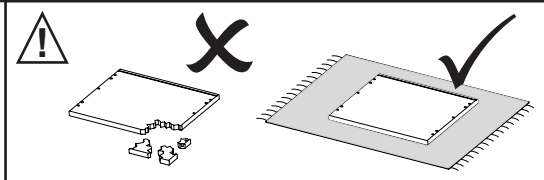

V1



C	D
	
2x 681 1645	3,5 x 13 2x 681 4887

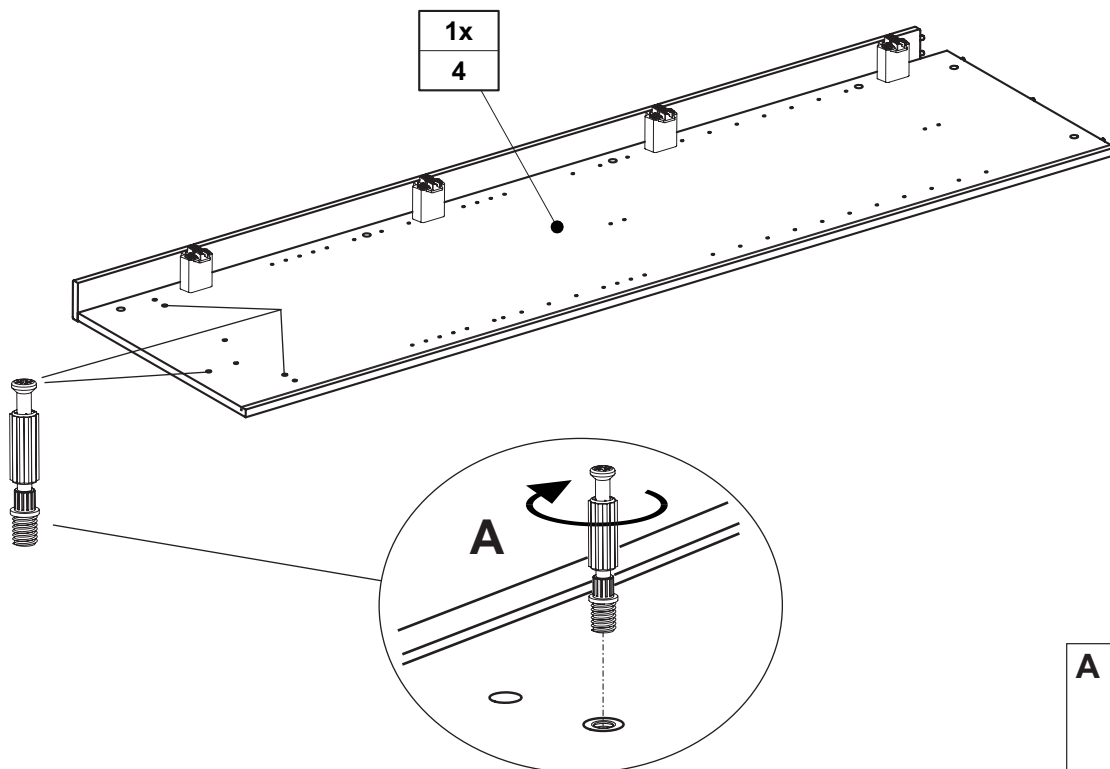

V2

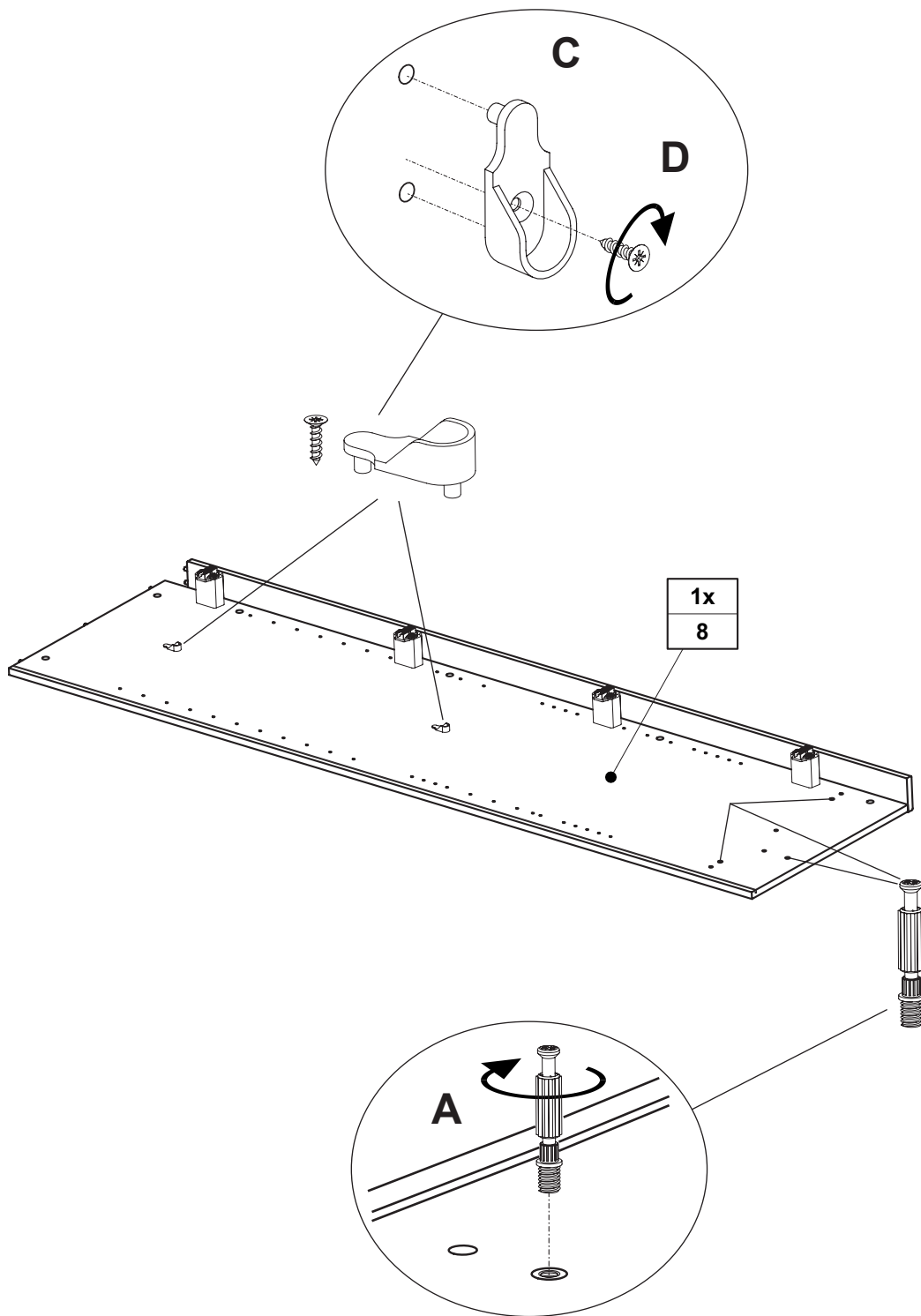

A

3x 681 0759

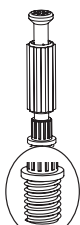
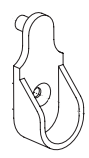



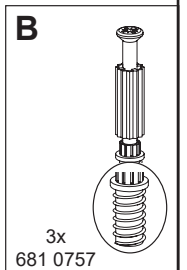
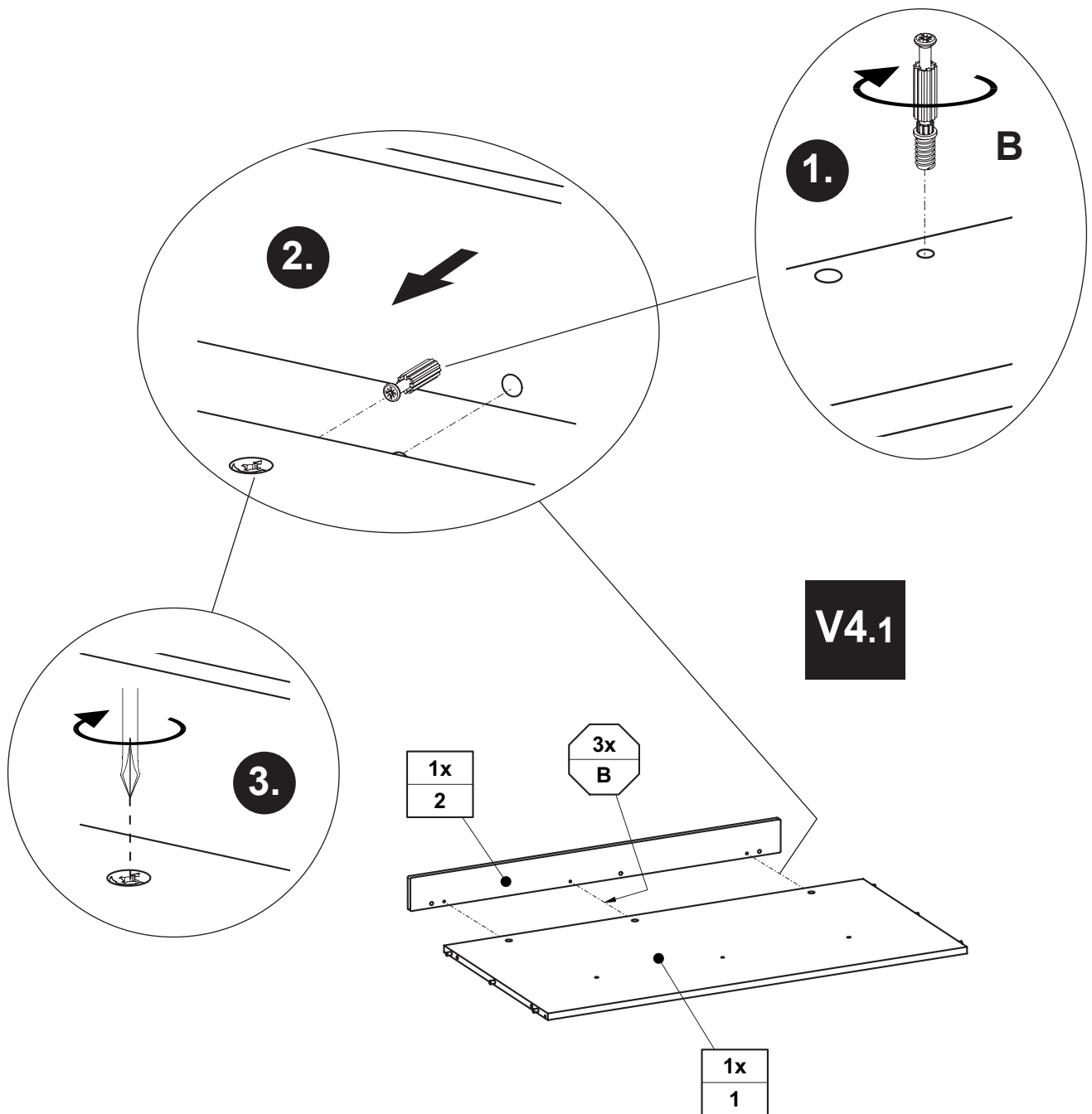

1x
8

<p>A</p>  <p>3x 681 0759</p>	<p>C</p>  <p>2x 681 1645</p>	<p>D</p>  <p>3,5 x 13 2x 681 4887</p>
--	--	---

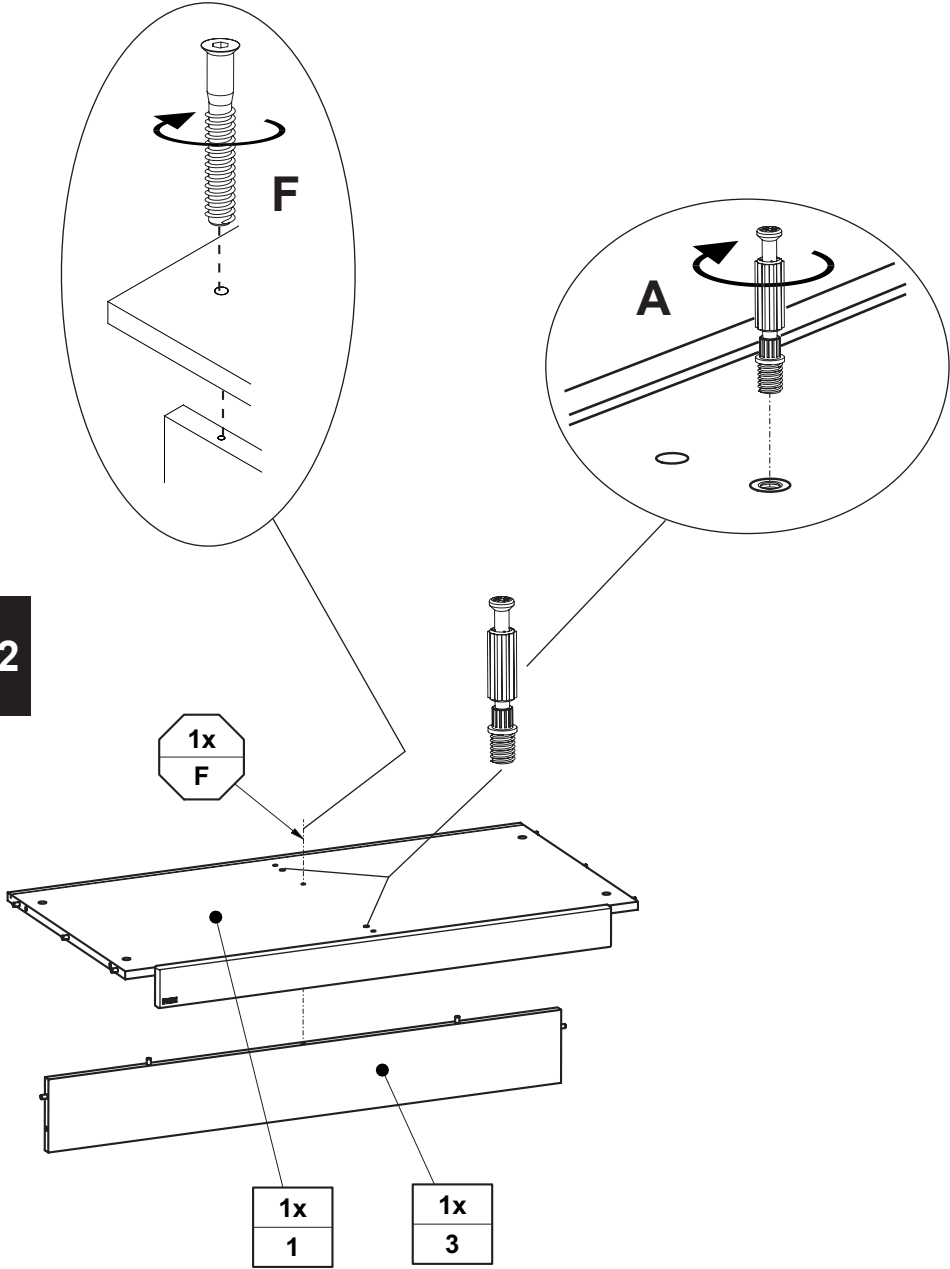

V4.2

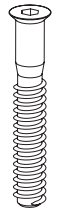

A  2x 681 0759	F  6,3 x 50 1x 681 5311	 SW4 1x 681 3011
---	---	--

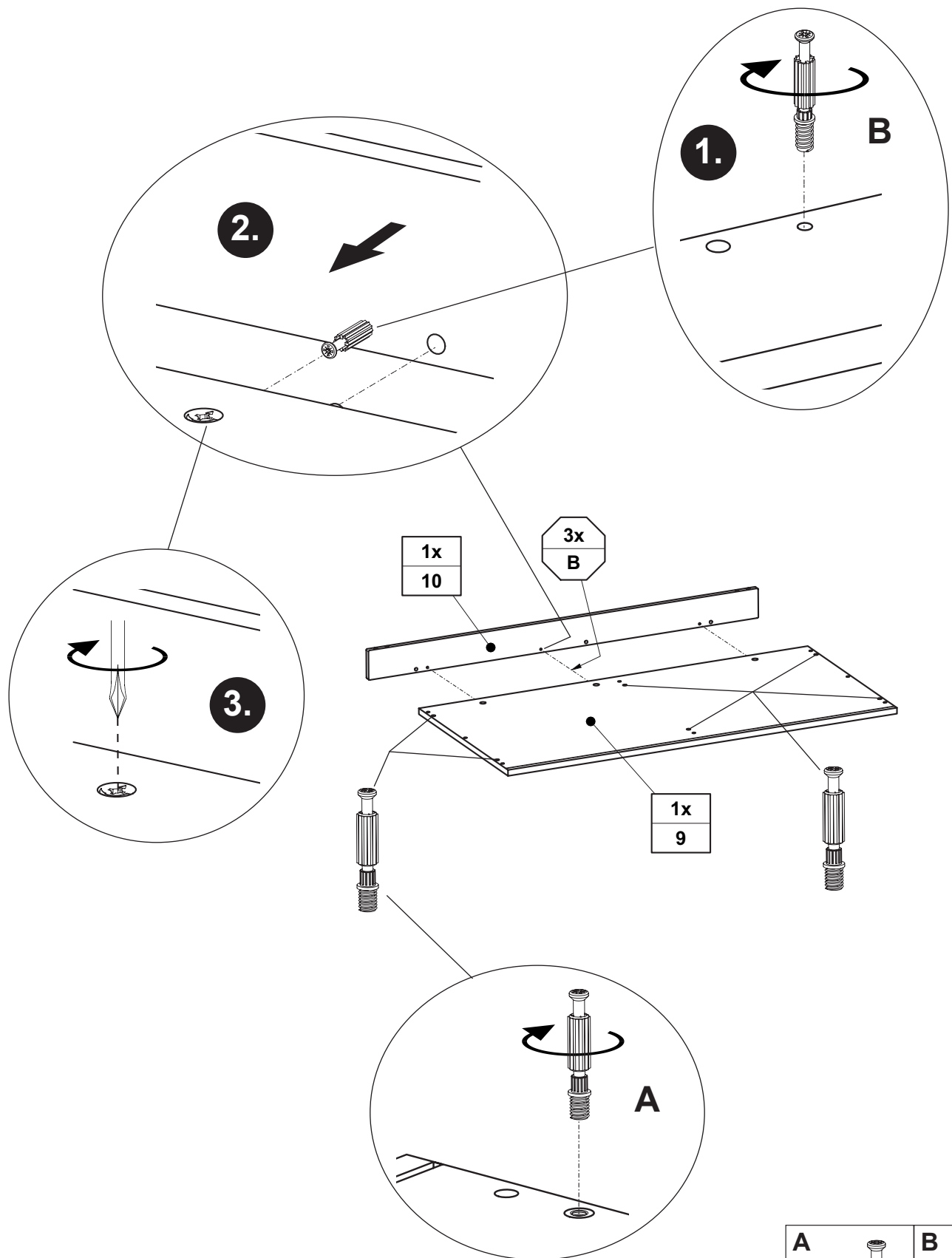

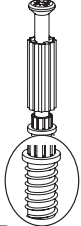
A		B	
6x		3x	
681 0759		681 0757	

V6

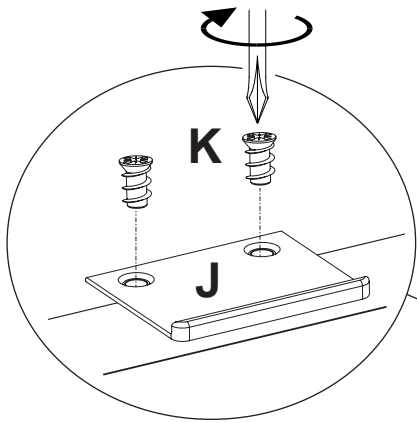

2x
K

1x
J

1x
13

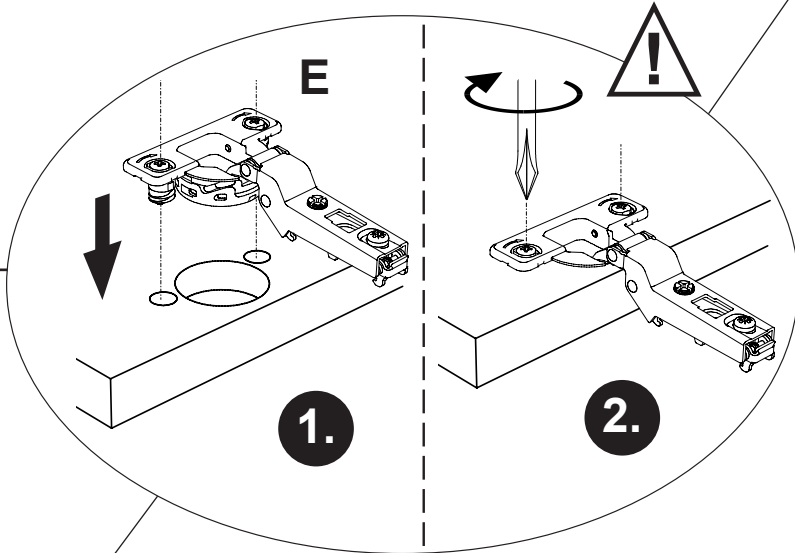
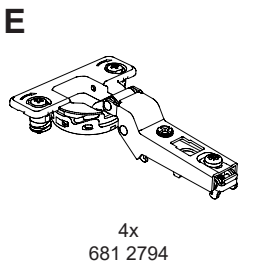
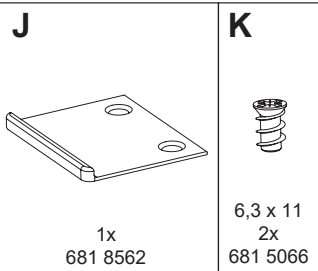
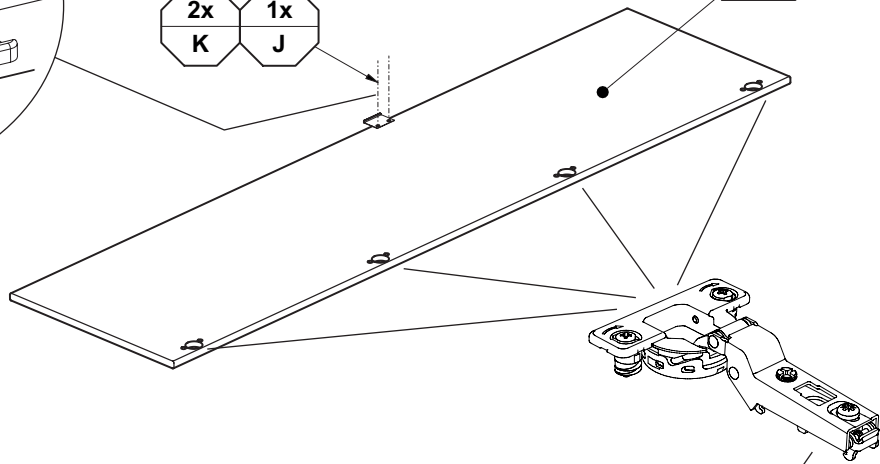

V7

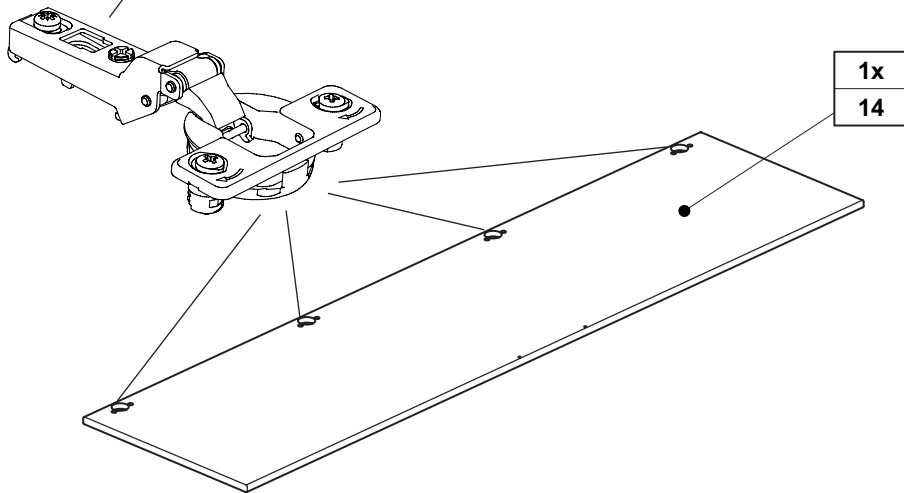

1x
14

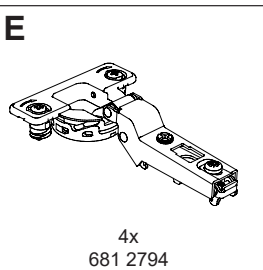

M1

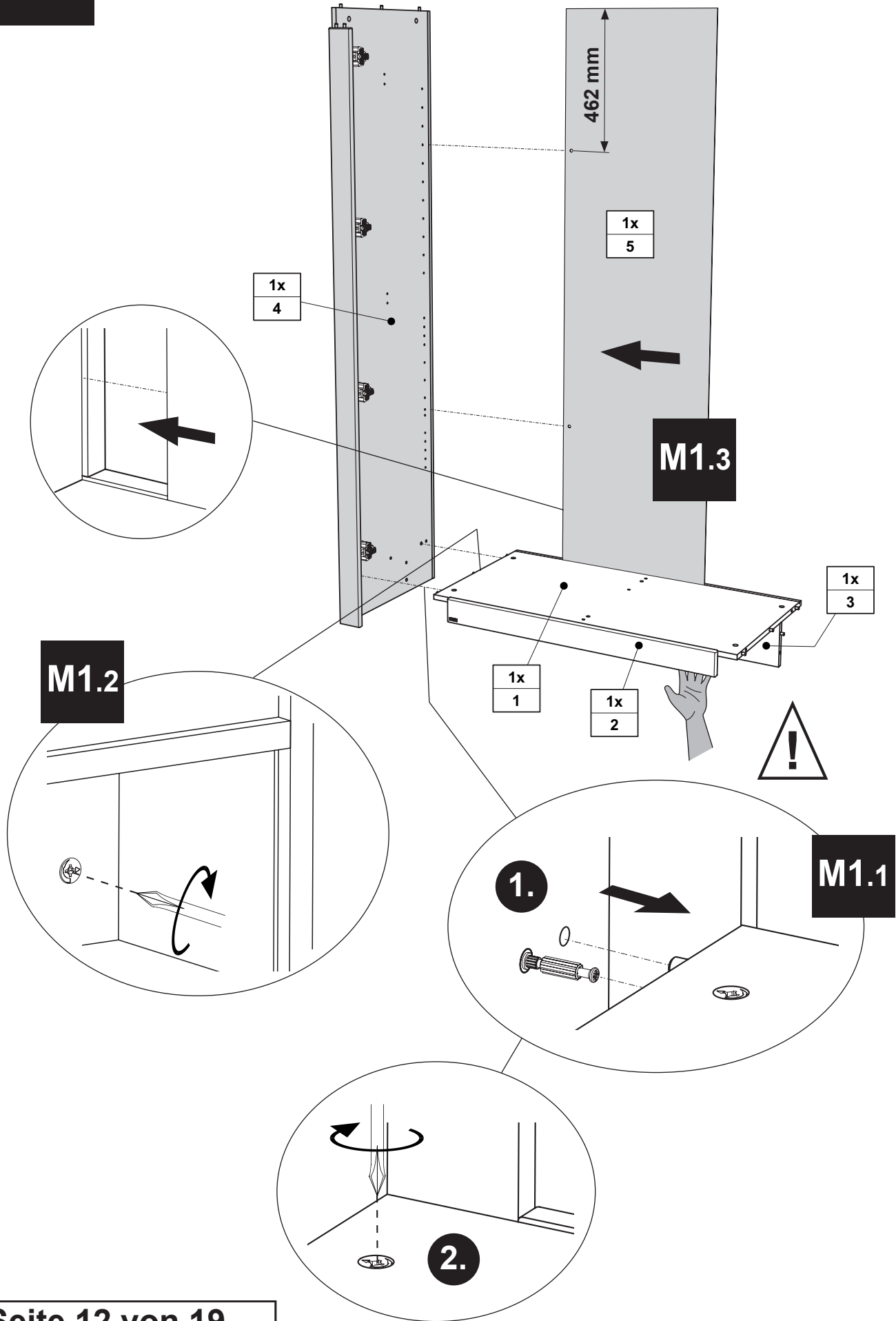

M2.1

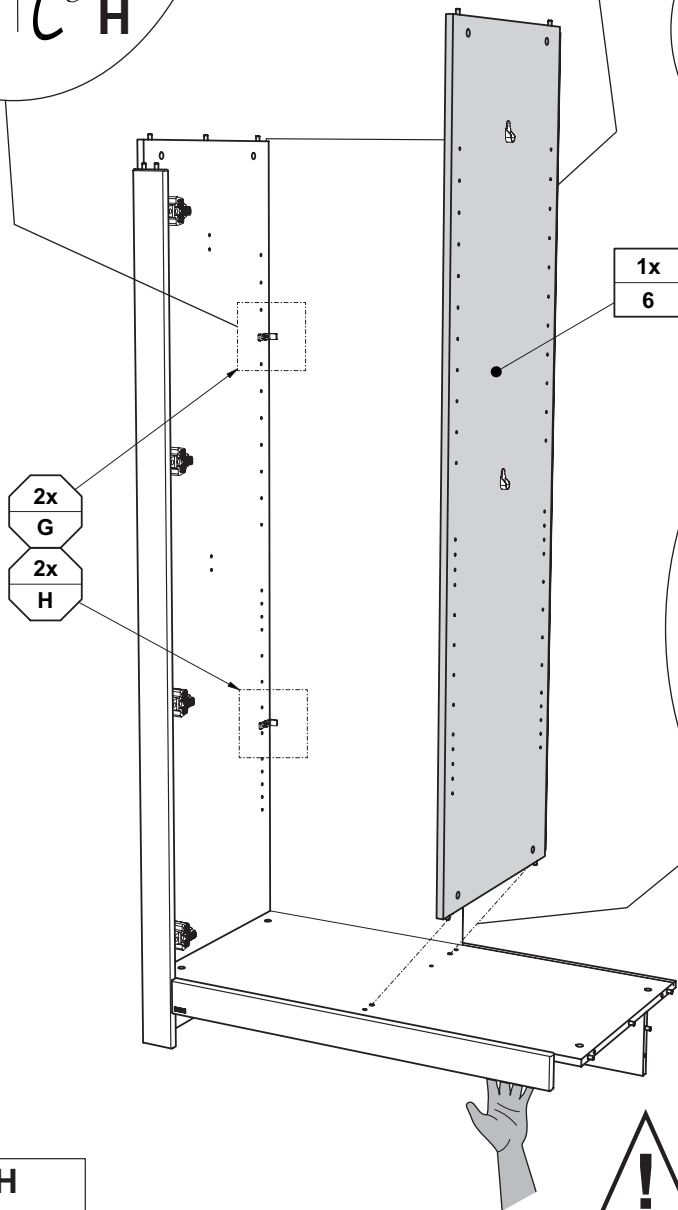
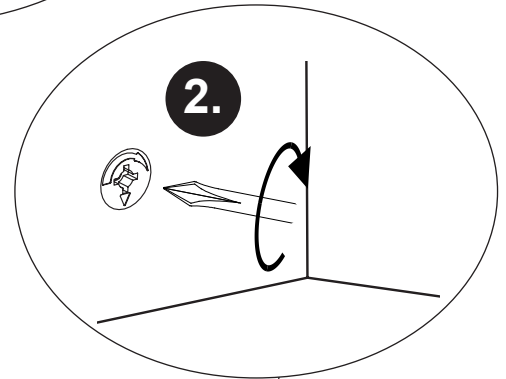
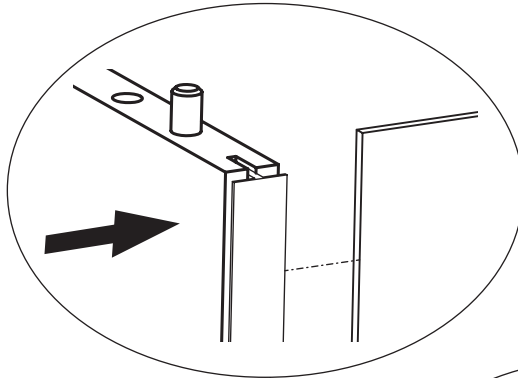
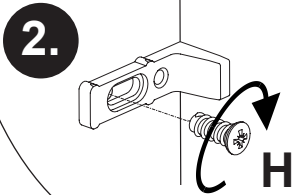
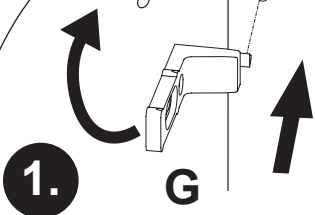

M2.2

1.

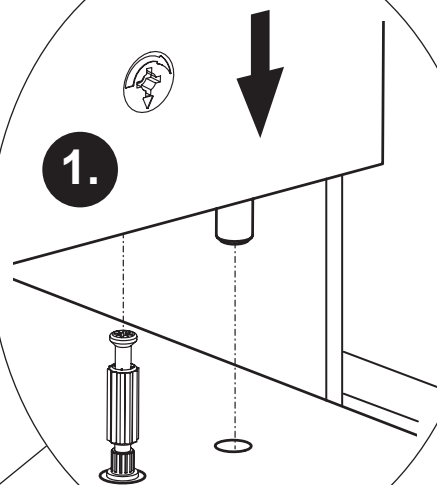

G

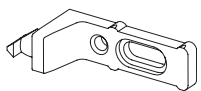

2x
681 2497

H



6,3 x 15
2x
681 5060

M3

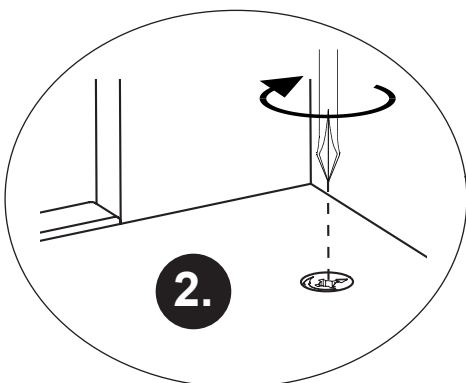
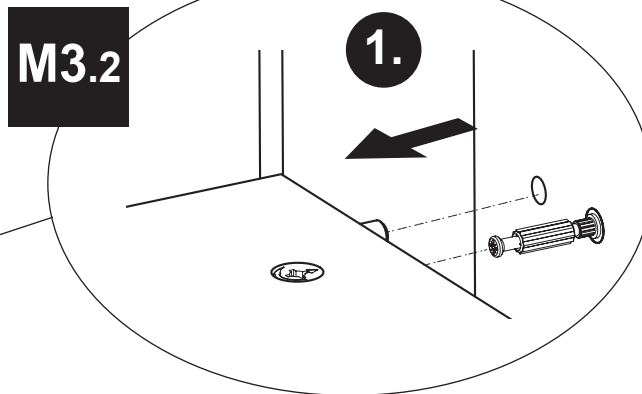
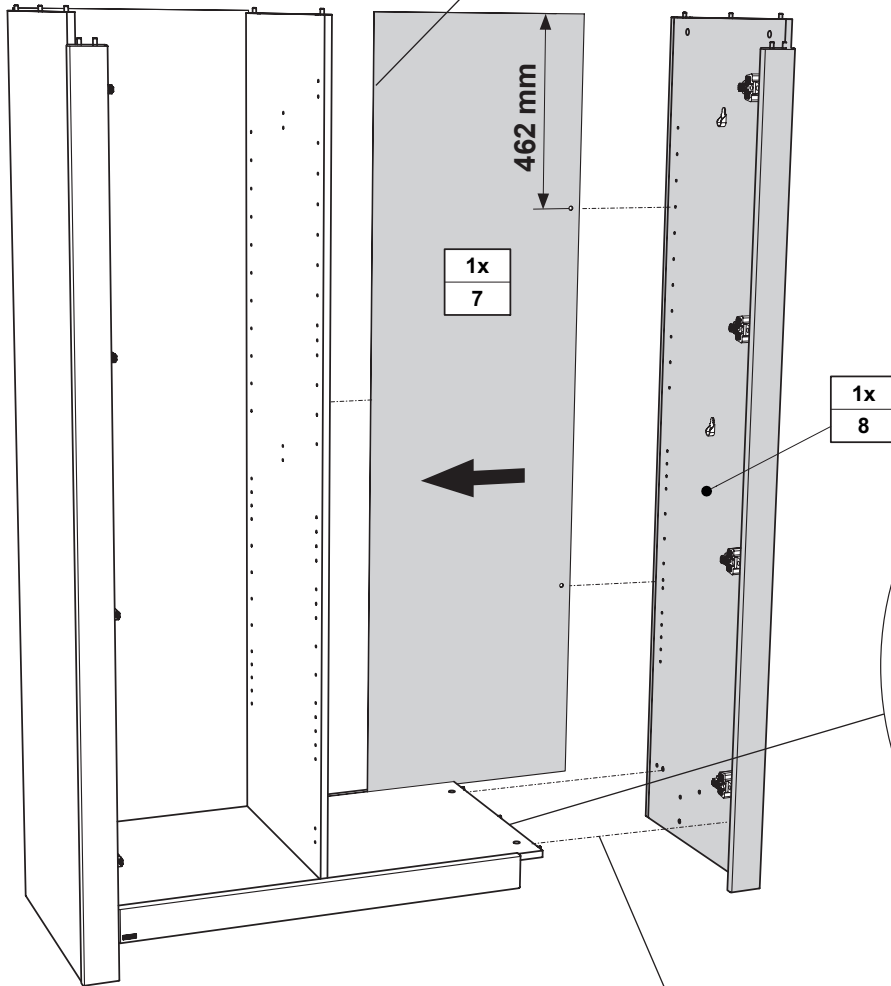
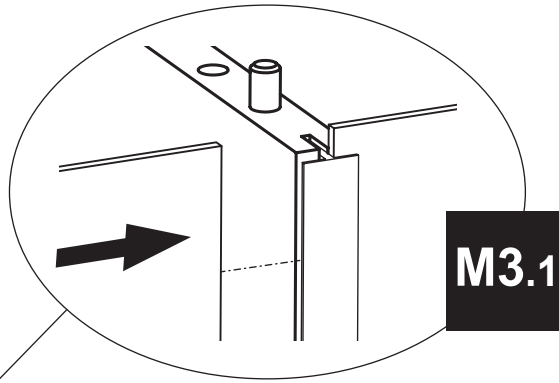

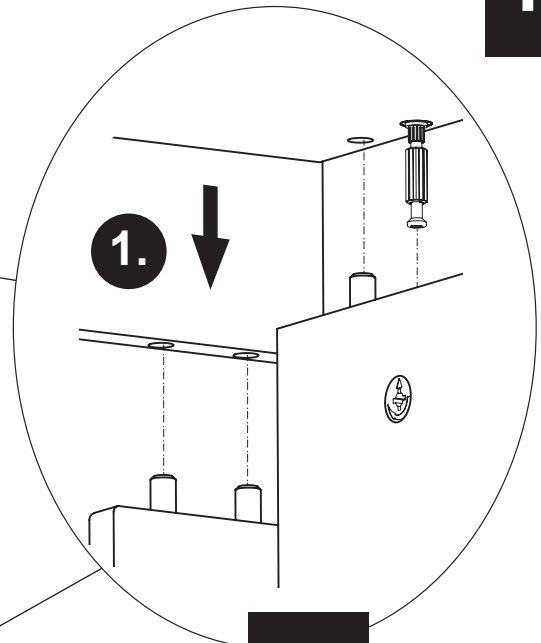
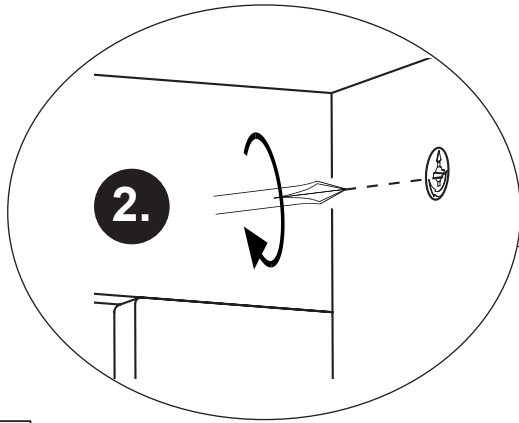

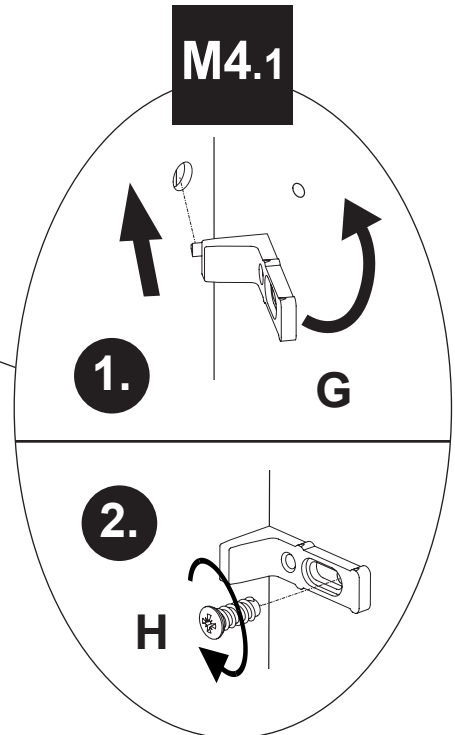
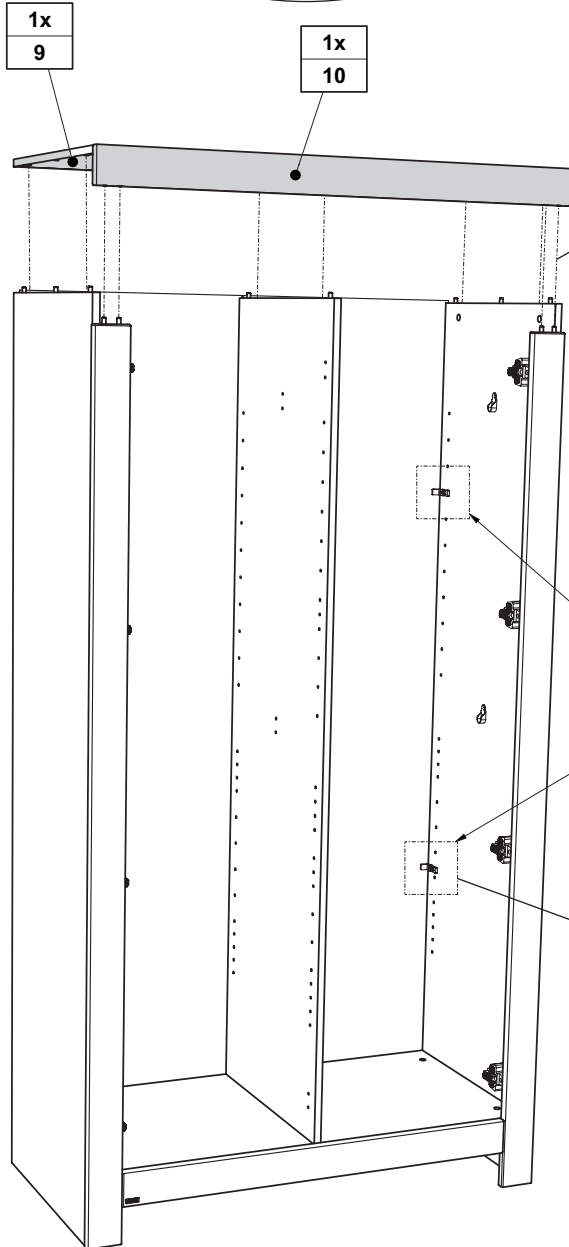

M4.2



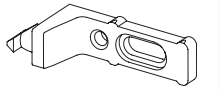

M4.1

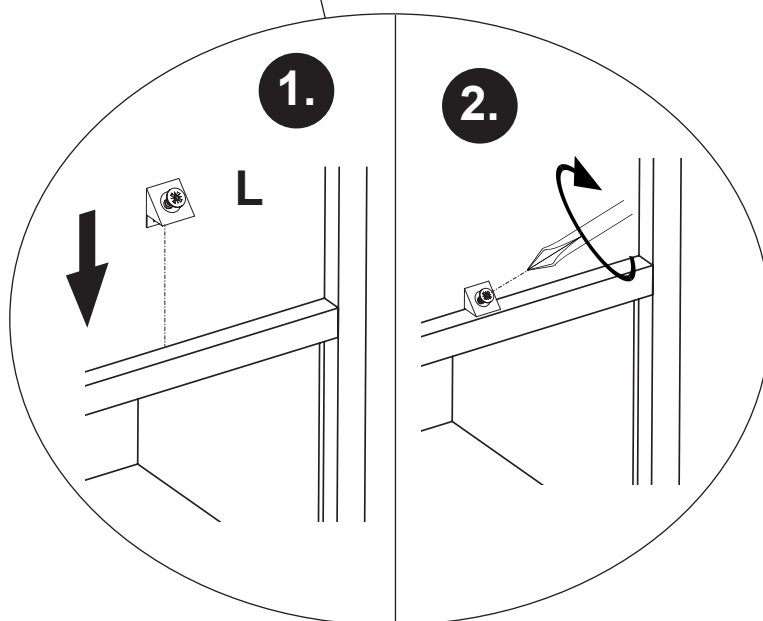
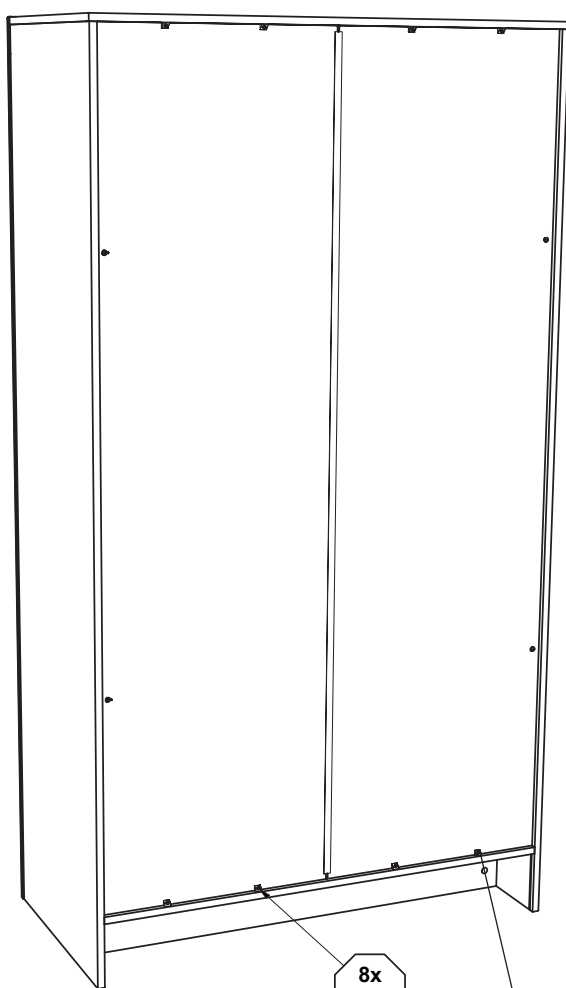
G	H
	
2x 681 2497	6,3 x 15 2x 681 5060

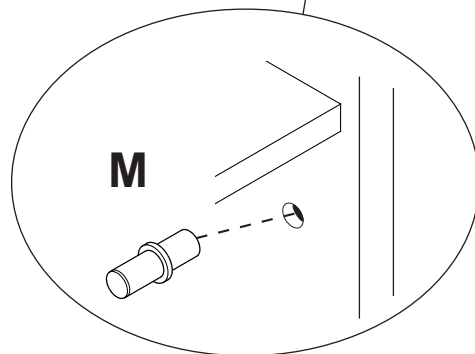
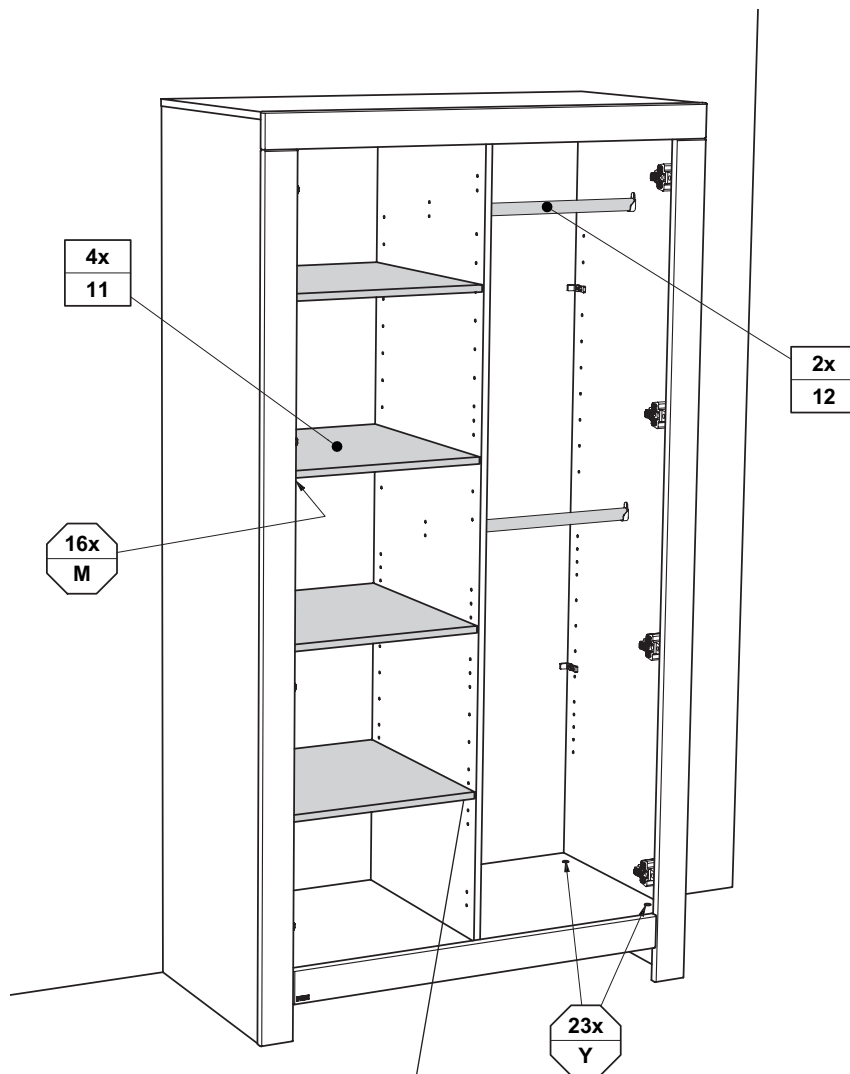



M	Y
	
16x 681 0350	Eiche oak 23x 683 0104

M7

PK-Nr. 2800

1x Z13
1x Z12
2x Z11

Kippsicherung !
Tilt protection !
Dispositif anti-basculement !
Kantelbeveiliging !
Защита от опрокидывания !
防傾倒装置 !

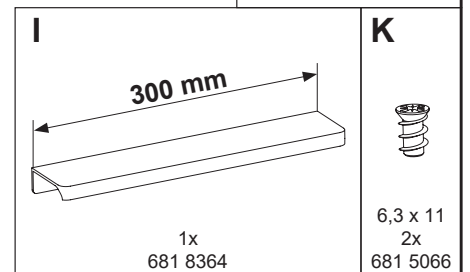
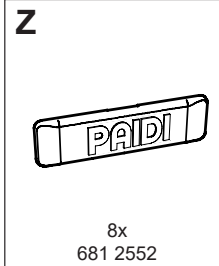
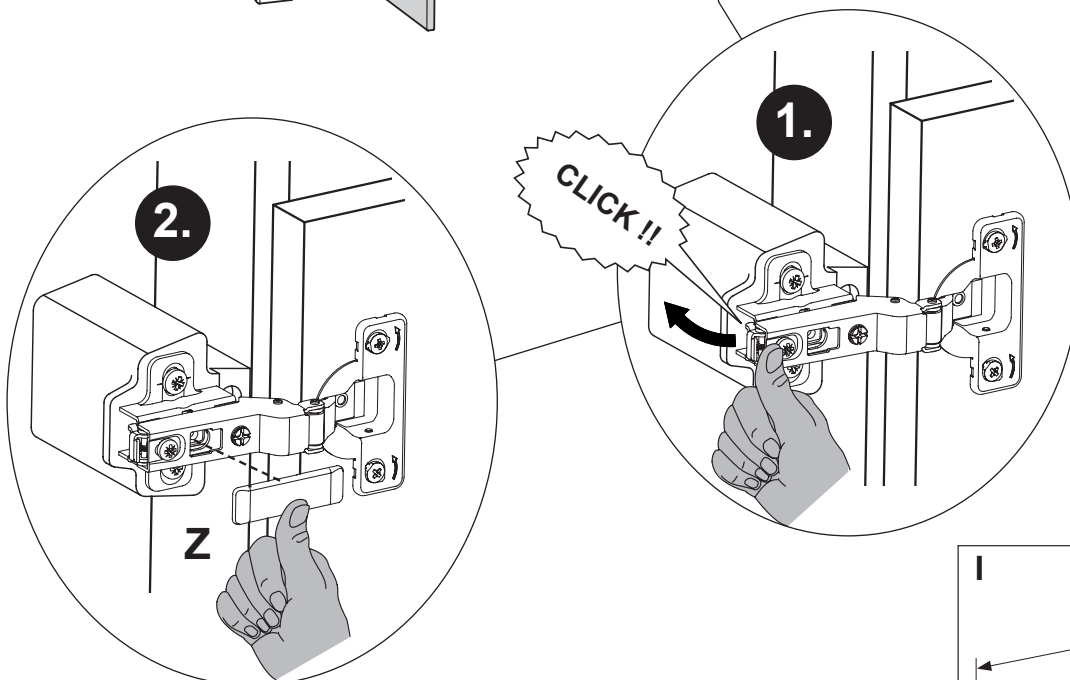
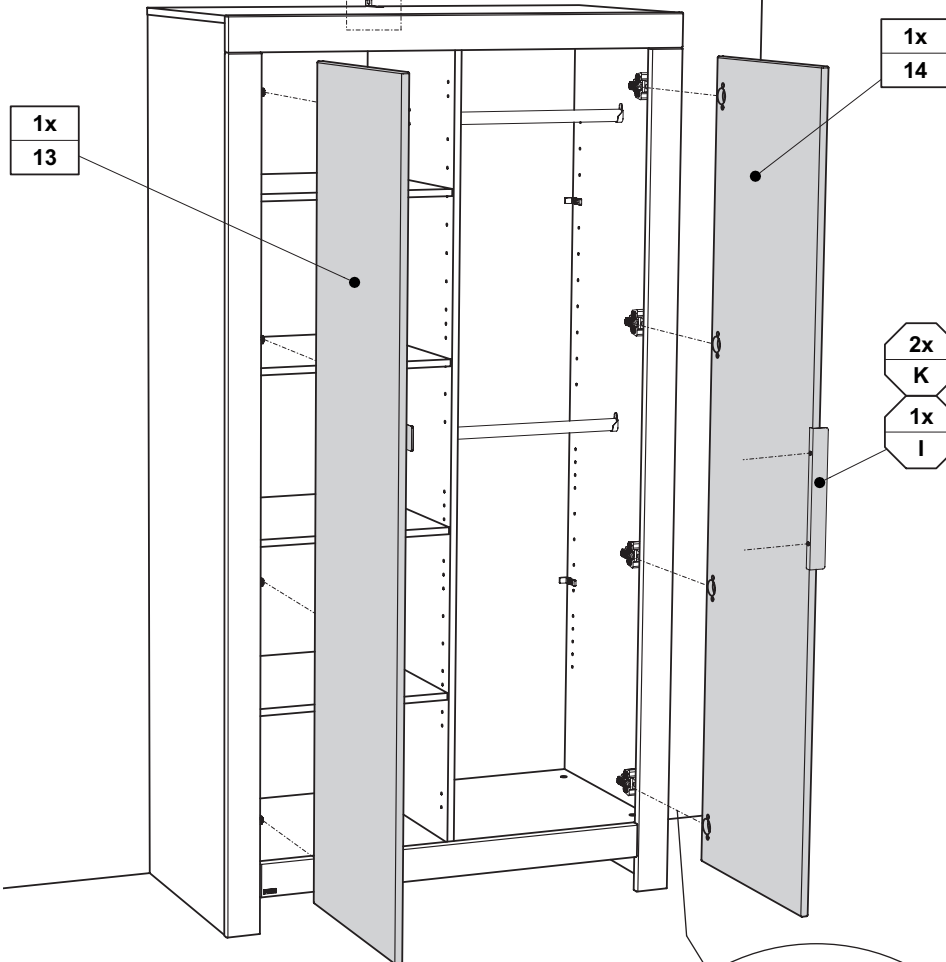

Justierung der Türen

Adjustement of doors
Réglage des portes
Afstelling van de deuren
Регулировка дверей
门的调整

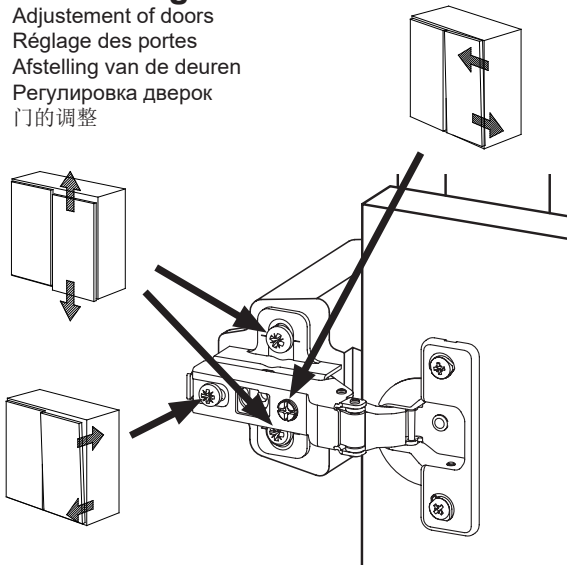

Demontage der Türen

Disassembly of doors
Démontage des portes
Demontage van de deuren
Демонтаж дверей
拆卸门

