

# INSTRUCTION MANUAL

## MICROWAVE OVEN

MW3-AG25PFI(MG)

Please review this instruction manual before operating.

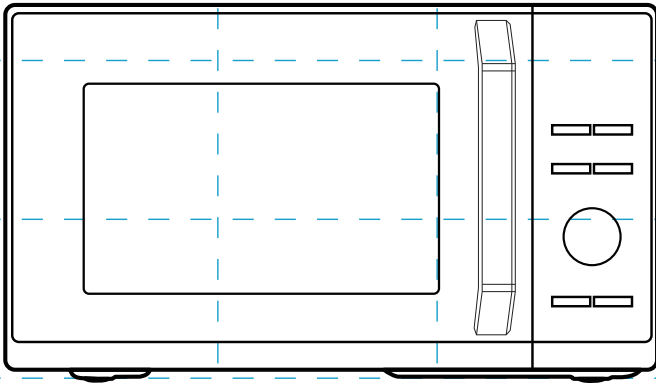

# CONTENTS

## PRODUCT SAFETY

Precautions to avoid possible exposure to excessive microwave energy .....	EN-01
Specifications .....	EN-02
Important safety instructions .....	EN-03
To reduce the risk of injury to persons grounding installation .....	EN-08
Cleaning .....	EN-10
Utensils .....	EN-11
Materials you can use in microwave oven .....	EN-12
Materials can not be used in microwave oven .....	EN-14

## PRODUCT SETTING

Setting up your oven .....	EN-15
----------------------------	-------

## INSTRUCTION FOR USE

Before using for the first time .....	EN-18
Operation .....	EN-19
Control panel and features .....	EN-19
1. Setting the clock .....	EN-20
2. Setting the kitchen timer .....	EN-21
3. Microwave cooking .....	EN-21
4. Grilling cooking .....	EN-22
5. Combination cooking .....	EN-23
6. Defrost by time .....	EN-24
7. Defrost by weight .....	EN-24
8. Speedy cooking .....	EN-25
9. Multi-stage cooking .....	EN-25

10. Auto menu ..... EN-26

11. Lock function for children ..... EN-28

12. Inquiring function ..... EN-28

## CLEANING AND MAINTENANCE

Cleaning ..... EN-29

Trouble shooting ..... EN-31



BEFORE OPERATING THIS PRODUCT, READ, UNDERSTAND, AND FOLLOW THESE INSTRUCTIONS. BE SURE TO SAVE THIS BOOKLIST FOR FUTURE REFERENCE.

# PRODUCT SAFETY

## PRECAUTIONS TO AVOID POSSIBLE EXPOSURE TO EXCESSIVE MICROWAVE ENERGY

---

- (a). Do not attempt to operate this oven with the door open since this can result in harmful exposure to microwave energy. It is important not to break or tamper with the safety interlocks.
- (b). Do not place any object between the oven front face and the door or allow soil or cleaner residue to accumulate on sealing surfaces.
- (c). **WARNING:** If the door or door seals are damaged, the oven must not be operated until it has been repaired by a competent person.

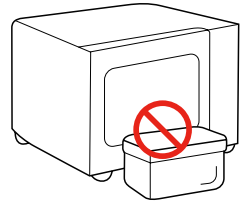

### ADDENDUM

---

If the apparatus is not maintained in a good state of cleanliness, its surface could be degraded and affect the lifespan of the apparatus and lead to a dangerous situation.



## SPECIFICATIONS

---

MODEL	MW3-AG25PFI(MG)
RATED VOLTAGE/FREQUENCY	230-240 V~ 50 Hz
MICROWAVE POWER INPUT	1400 W
MICROWAVE POWER OUTPUT	900 W
RATED INPUT (GRILL)	1000-1100 W



### NOTE

All pictures in this manual are for illustrative purposes only; these may be slightly different from the purchased equipment, please refer to the actual product.

# IMPORTANT SAFETY INSTRUCTIONS



## WARNING

To reduce the risk of fire, electric shock, injury to persons or exposure to excessive microwave oven energy when using your appliance, follow basic precautions, including the following:



Read and follow the specific: **“PRECAUTIONS TO AVOID POSSIBLE EXPOSURE TO EXCESSIVE MICROWAVE ENERGY”**.



This appliance can be used by children aged from 8 years and above and persons with reduced physical, sensory or mental capabilities or lack of experience and knowledge if they have been given supervision or instruction concerning use of the appliance in a safe way and understand the hazards involved. Children shall not play with the appliance. Cleaning and user maintenance shall not be made by children without supervision.



Keep the appliance and its cord out of reach of children less than 8 years.

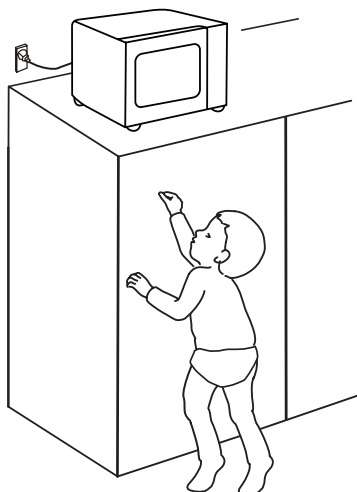

If the supply cord is damaged, it must be replaced by the

# IMPORTANT SAFETY INSTRUCTIONS

manufacturer, its service agent or similarly qualified persons in order to avoid a hazard.

---

 **WARNING:** Ensure that the appliance is switched off before replacing the lamp to avoid the possibility of electric shock.

---

 **WARNING:** It is hazardous for anyone other than a competent person to carry out any service or repair operation that involves the removal of a cover which gives protection against exposure to microwave energy.

---

 **WARNING:** Liquids and other foods must not be heated in sealed containers since they are liable to explode.

 When heating food in plastic or paper containers, keep an eye on the oven due to the possibility of ignition.

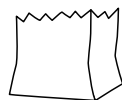

 Only use utensils that are suitable for use in microwave ovens.

---

 If smoke is emitted, switch off or unplug the appliance and keep the door closed in order to stifle any flames.

---

 Microwave heating of beverages can result in delayed eruptive boiling, therefore care must be taken when handling the container.

---

 The contents of feeding bottles and baby food jars shall be stirred or shaken and the temperature

# IMPORTANT SAFETY INSTRUCTIONS

checked before consumption, in order to avoid burns.

- 
-  The oven should be cleaned regularly and any food deposits removed. Please keep the waveguide area clean. Use soft damp cloth to clean it up when there is food splash residue on the waveguide area or the cavity. Failure to clean food residue may cause innocuous sparking or some smoke in the microwave cavity, discoloration of the cavity may also occur.

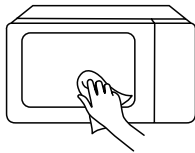

- 
-  Failure to maintain the oven in a clean condition could lead to deterioration of the surface that could adversely affect the life of the appliance and possibly

result in a hazardous situation.

- 
-  Only use the temperature probe recommended for this oven. (for ovens provided with a facility to use a temperature-sensing probe.)

- 
-  The microwave oven must be operated with the decorative door open. (for ovens with a decorative door.)

- 
-  This appliance is intended to be used in household and similar applications such as:
1. staff kitchen areas in shops, offices and other working environments;
  2. by clients in hotels, motels and other residential type environments;
  3. farm houses;
  4. bed and breakfast type environments.

# IMPORTANT SAFETY INSTRUCTIONS

 The microwave oven is intended for heating food and beverages. Drying of food or clothing and heating of warming pads, slippers, sponges, damp cloth and similar may lead to risk of injury, ignition or fire.

---

 The rear surface of appliances shall be placed against a wall.

---

 The temperature of accessible surfaces may be high when the appliance is operating.

---

 **WARNING:** When the appliance is operated in the combination mode, children should only use the oven under adult supervision due to the temperatures generated.

 The appliance is intended to be used freestanding.

---

 Eggs in their shell and whole hard-boiled eggs should not be heated in microwave ovens since they may explode, even after microwave heating has ended.

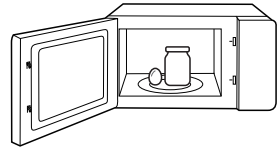

 The microwave oven shall not be placed in a cabinet unless it has been tested in a cabinet.



---

 Metallic containers for food and beverages are not allowed during microwave cooking.

---

 The appliance shall not be cleaned with a steam cleaner.

# IMPORTANT SAFETY INSTRUCTIONS

-  The appliances are not intended to be operated by means of an external timer or separate remote-control system.
-  The appliance must not be installed behind a decorative door in order to avoid overheating. (This is not applicable for appliances with decorative door.)

READ CAREFULLY AND KEEP FOR  
FUTURE REFERENCE

# TO REDUCE THE RISK OF INJURY TO PERSONS GROUNDING INSTALLATION

This appliance must be grounded. In the event of an electrical short circuit, grounding reduces the risk of electric shock by providing an escape wire for the electric current.

This appliance is equipped with a cord having a grounding wire with a grounding plug. The plug must be plugged into an outlet that is properly installed and grounded.

**WARNING** - Improper use of the grounding can result in a risk of electric shock. Consult a qualified electrician or serviceman if the grounding instructions are not completely understood or if doubt exists as to whether the appliance is properly grounded. If it is necessary to use an extension cord, use only a 3-wire extension cord.



**DANGER**

**Electric Shock Hazard:**

Touching some of the internal components can cause serious personal injury or death. Do not disassemble this appliance.

# TO REDUCE THE RISK OF INJURY TO PERSONS GROUNDING INSTALLATION



**WARNING**

## Electric Shock Hazard:

Improper use of the grounding can result in electric shock. Do not plug into an outlet until appliance is properly installed and grounded.

1. A short power-supply cord is provided to reduce the risks resulting from becoming entangled in or tripping over a longer cord.
2. If a long cord or extension cord is used:
  - (1). The marked electrical rating of the cord set or extension cord should be at least as great as the electrical rating of the appliance.
  - (2). The extension cord must be a grounding-type 3-wire cord.
  - (3). The longer cord should be arranged so that it will not drape over the counter top or tabletop where it can be pulled on by children or tripped over unintentionally.



# CLEANING

Be sure to unplug the appliance from the power supply.

1. Clean the cavity of the oven after using with a slightly damp cloth.
2. Clean the accessories in the usual way in soapy water.
3. The door frame and seal and neighbouring parts must be cleaned carefully with a damp cloth when they are dirty.
4. Do not use harsh abrasive cleaners or sharp metal scrapers to clean the oven door glass since they can scratch the surface, which may result in shattering of the glass.
5. Cleaning Tip---For easier cleaning of the cavity walls that the food cooked can touch: Place half a lemon in a bowl, add 300ml (1/2 pint) water and heat on 100% microwave power for 10 minutes. Wipe the oven clean using a soft, dry cloth.

# UTENSILS



## Personal Injury Hazard:

It is hazardous for anyone other than a competent person to carry out any service or repair operation that involves the removal of a cover which gives protection against exposure to microwave energy. See the instructions on "**Materials you can use in microwave oven**" or "**Materials can not be used in microwave oven**".

There may be certain non-metallic utensils that are not safe to use for microwaving. If in doubt, you can test the utensil in question following the procedure below.

## Utensil Test:



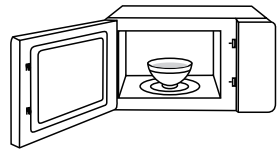



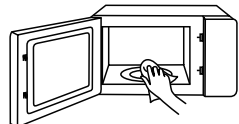









1. Fill a microwave-safe container with 1 cup of cold water (250ml) along with the utensil in question.
2. Cook on maximum power for 1 min.
3. Carefully feel the utensil. If the empty utensil is warm, do not use it for microwave cooking.
4. Do not exceed 1 min cooking time.







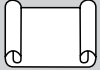



KEEP THE CAVITY AND WAVE GUIDE AREA CLEAN













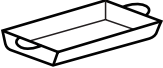



# MATERIALS YOU CAN USE IN MICROWAVE OVEN

UTENSILS	REMARKS
 Browning dish	Follow manufacturer's instructions. The bottom of browning dish must be at least 3/16 inch (5mm) above the turntable. Incorrect usage may cause the turntable to break. 
 Dinnerware	Microwave-safe only. Follow manufacturer's instructions. Do not use cracked or chipped dishes. 
 Glass jars	Always remove lid. Use only to heat food until just warm. Most glass jars are not heat resistant and may break. 
 Glassware	Heat-resistant oven glassware only. Make sure there is no metallic trim. Do not use cracked or chipped dishes. 
 Oven cooking bags	Follow manufacturer's instructions. Do not close with metal tie. Make slits to allow steam to escape. 
 Paper plates and cups	Use for short-term cooking/warming only. Do not leave oven unattended while cooking. 
 Paper towels	Use to cover food for reheating and absorbing fat. Use with supervision for a short-term cooking only. 
 Parchment paper	Use as a cover to prevent splattering or a wrap for steaming. 

# MATERIALS YOU CAN USE IN MICROWAVE OVEN

UTENSILS	REMARKS
 <p data-bbox="153 475 221 496">Plastic</p>	<p data-bbox="331 376 885 515">Microwave-safe only. Follow the manufacturer's instructions. Should be labeled "Microwave Safe". Some plastic containers soften, as the food inside gets hot. "Boiling bags" and tightly closed plastic bags should be slit, pierced or vented as directed by package.</p> 
 <p data-bbox="126 659 248 679">Plastic wrap</p>	<p data-bbox="331 576 880 655">Microwave-safe only. Use to cover food during cooking to retain moisture. Do not allow plastic wrap to touch food.</p> 
 <p data-bbox="113 823 263 844">Thermometers</p>	<p data-bbox="331 770 869 791">Microwave-safe only (meat and candy thermometers).</p> 
 <p data-bbox="132 983 243 1003">Wax paper</p>	<p data-bbox="331 919 803 967">Use as a cover to prevent splattering and retain moisture.</p> 

# MATERIALS CAN NOT BE USED IN MICROWAVE OVEN

UTENSILS	REMARKS
 <p>Aluminum tray</p>	May cause arcing. Transfer food into microwave-safe dish. 
 <p>Food carton with metal handle</p>	May cause arcing. Transfer food into microwave-safe dish. 
 <p>Metal or metal trimmed utensils</p>	Metal shields the food from microwave energy. Metal trim may cause arcing. 
 <p>Metal twist ties</p>	May cause arcing and could cause a fire in the oven. 
 <p>Paper bags</p>	May cause a fire in the oven. 
 <p>Plastic foam</p>	Plastic foam may melt or contaminate the liquid inside when exposed to high temperature. 
 <p>Wood</p>	Wood will dry out when used in the microwave oven and may split or crack. 

# PRODUCT SETTING

## SETTING UP YOUR OVEN

### NAMES OF MICROWAVE OVEN PARTS AND ACCESSORIES

Remove the oven and all materials from the carton and oven cavity.

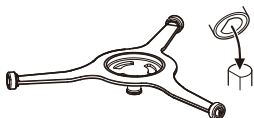

Turntable Ring Assembly

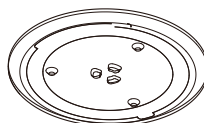

Glass Tray

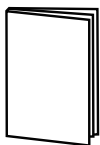

Instruction Manual

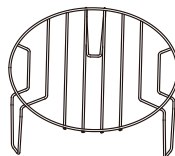

Grill Rack (Can not be used in microwave function and must be placed on the glass tray)

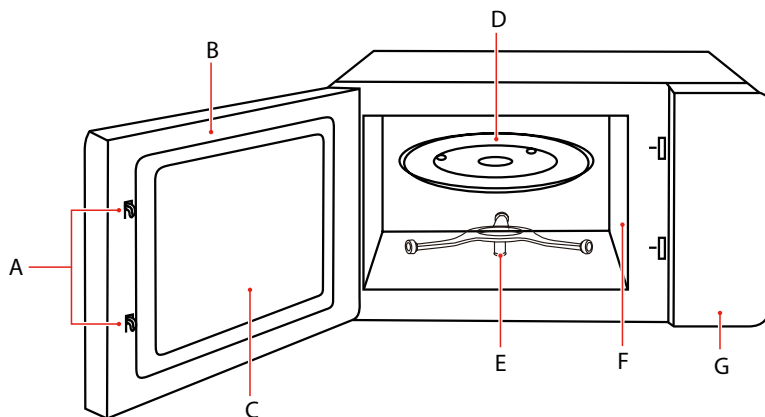

- A) Safety interlock system
- B) Door assembly
- C) Observation window
- D) Glass tray

- E) Turntable ring assembly
- F) Waveguide cover
- G) Control panel



In case of any differences between the appliance and the pictures in this manual, the product shall prevail.

# SETTING UP YOUR OVEN

## TURNTABLE INSTALLATION

Clean the cooking compartment and place the turntable.

For new installations, make sure all packaging and shipping tape has been removed from the turntable shaft.

Before using the appliance to prepare food for the first time, you will need to put the turntable in place correctly. You must clean the cooking compartment and accessories. You can also refer them to the cleaning section.

How to put the turntable in place:

1. Place the turntable ring assembly ② into the recess in the cooking compartment.
2. Place the glass tray ① on the turntable ring assemblies ②.

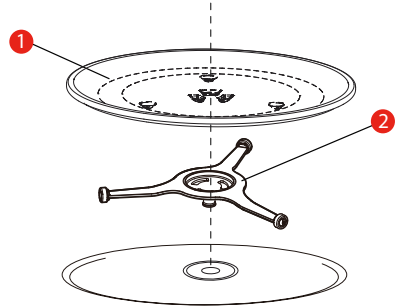

- 1) Glass Tray  
2) Turntable Ring Assembly

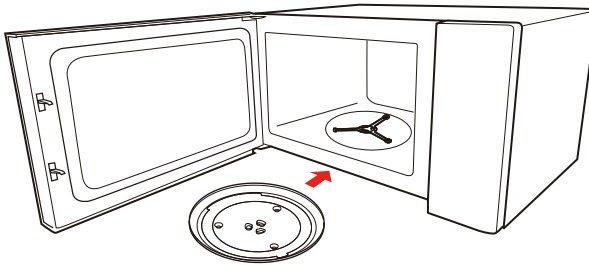

### NOTE

- Never use the appliance without the turntable. Make sure that it is properly engaged. The turntable can turn clockwise or anti-clockwise.
- Never place the glass tray upside down. The glass tray should never be restricted.
- Both glass tray and turntable ring assembly must always be used during cooking.
- All food and containers of food are always placed on the glass tray for cooking.
- Never restrict the movement of the turntable.
- If glass tray or turntable ring assembly cracks or breaks, contact your nearest authorized service center.

## COUNTERTOP INSTALLATION

Remove all packing material and accessories. Examine the oven for any damage such as dents or broken door. Do not install if oven is damaged.

Cabinet: Remove any protective film found on the microwave oven cabinet surface. Do not remove the waveguide cover that is attached to the oven cavity to protect the magnetron.

## INSTALLATION

1. Select a level surface that provide enough open space for the intake and/or outlet vents.
  - a. The minimum installation height is 85cm.
  - b. The rear surface of appliance shall be placed against a wall. Leave a minimum clearance of 30cm above the oven. A minimum clearance of 20cm is required between the oven and any adjacent walls.
  - c. Do not remove the legs from the bottom of the oven.
  - d. Blocking the intake and/or outlet openings can damage the oven.
  - e. Place the oven as far away from radios and TV as possible. Operation of microwave oven may cause interference to your radio or TV reception.

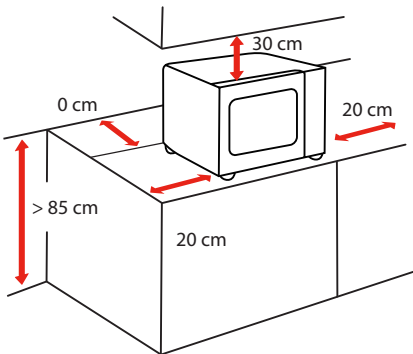

SIDE	DISTANCE CM
Top	30cm
Left	20cm
Right	20cm
Behind	0cm
Front	Open

2. Plug microwave oven into a standard household outlet. Be sure the voltage and the frequency is the same as the voltage and the frequency on the rating label.



**NOTE**

- Do not install oven over a range cooktop or other heat-producing appliance. If installed near or over a heat source, the oven could be damaged and the warranty would be void.

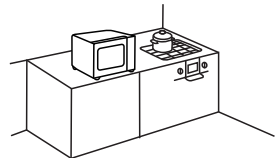

The accessible surface may be hot during operation



# INSTRUCTION FOR USE

## BEFORE USING FOR THE FIRST TIME

**It is normal that the oven may produce unpleasant odors when it is used for the first time.**

This section tells you what you need to do before using your microwave to prepare food for the first time. Read the section entitled "**PRODUCT SAFETY**" beforehand.

Before you can use your new appliance, you will need to put the turntable in place correctly. You must also clean the cooking compartment and accessories.



### NOTE

- Never use the appliance without the turntable.
- Make sure that it is properly engaged. The turntable can turn clockwise or anti-clockwise.

# OPERATION

## CONTROL PANEL AND FEATURES

---

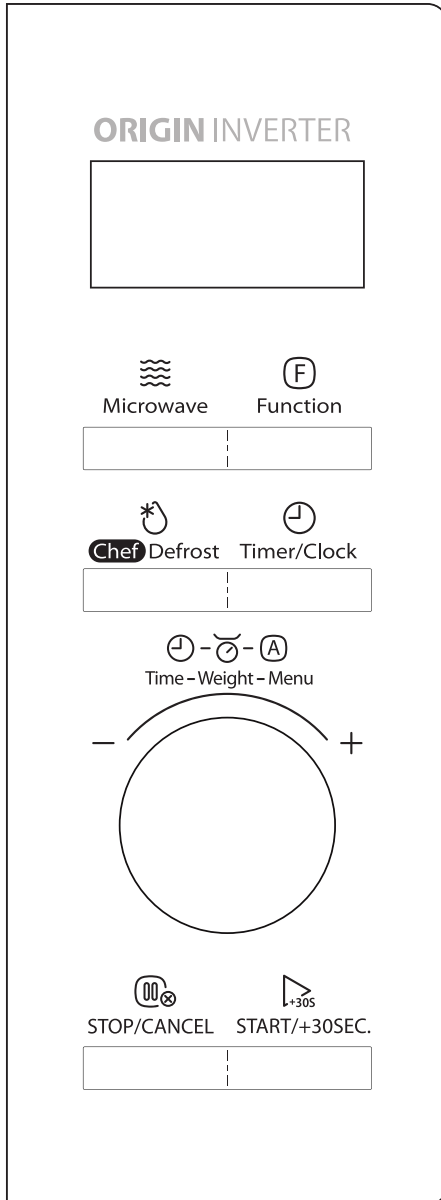

## 1. SETTING THE CLOCK



---

**a** Press  **Timer/Clock** twice, "00:00" will display.

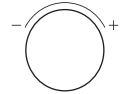

**b** Turn the knob to set the hour figures.



**c** Press  **Timer/Clock** or  **START/+30SEC.** to confirm the hour figures.





or

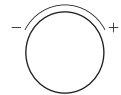

**d** Turn the knob to set the minute figures.



**e** Press  **Timer/Clock** or  **START/+30SEC.** to confirm. The clock is set.



or



### NOTE

- The clock is a 24-hour display. If the clock is not set, it will not work when powered.
- To reset the clock, please repeat step a to step e.

## 2. SETTING THE KITCHEN TIMER

**a** Press  once, "00:00" will display.



**b** Turn the knob to set the desired time.  
The maximum time value is "95:00".

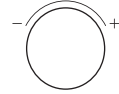

**c** Press  to confirm. The timer starts counting down.



**NOTE**

- The kitchen timer is a timer.
- Any other program can't be set during the kitchen timer.

## 3. MICROWAVE COOKING

**10 power levels are available.**

LEVEL	POWER	DISPLAY
1	100%	P100
2	90%	P90
3	80%	P80
4	70%	P70
5	60%	P60
6	50%	P50
7	40%	P40
8	30%	P30
9	20%	P20
10	10%	P10

Press  repeatedly to choose the power level.

**a** or

Press  once, and then turn the knob to set the power level.

The 10 power levels are available.



**b** Press  to confirm the power level.



**c** Turn the knob to set the cooking time, the maximum time value is "95:00".



**d** Press  to start cooking.



## 4. GRILLING COOKING

---

**a** Press  once, "G-1" will display.



**b** Press  to confirm the mode.



**c** Turn the knob to set the cooking time, the maximum time value is "95:00".

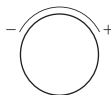



d Press  to start cooking.



• The buzzer will sound to remind you to turn the food over during cooking. If no operation, the oven will continue working.

## 5. COMBINATION COOKING

- a Press  repeatedly to choose the cooking mode you want. "C-1, C-2" are available.  
or  
Press  once, and then turn the knob to choose the cooking mode.



b Press  to confirm the mode.



c Turn the knob to set the cooking time, the maximum time value is "95:00".

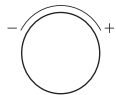

d Press  to start cooking.



### COMBINATION COOKING CHART

FUNCTION	DISPLAY	MICROWAVE POWER	GRILL POWER
Combi. 1	C-1	55%	45%
Combi. 2	C-2	36%	64%

## 6. DEFROST BY TIME

a Press  once, and then "dEF1" will display.



b Turn the knob to set the desired defrost time, the maximum time value is "95:00".

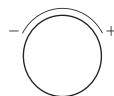

c Press  to start defrosting.



### NOTE

- The buzzer will sound to remain you of turning over the food during defrosting. If no operation, the oven will continue working.
- The defrost power is P30 and it cannot be changed.

## 7. DEFROST BY WEIGHT

a Press  repeatedly to choose the type of the food, and then "dEF2", "dEF3", or "dEF4" will display.



b Turn the knob to set the weight of the food, it should be within "100g-2000g".

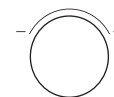

c Press  to start defrosting.



LED DISPLAY	FOOD	WEIGHT
dEF2	Meat	100g-2000g
dEF3	Chicken	100g-2000g
dEF4	Fish	100g-2000g



### NOTE

- The buzzer will sound to remain you of turning over the food during defrosting. If no operation, the oven will continue working.

## 8. SPEEDY COOKING

**a** Turn the knob left to set a cooking time with 100% power.

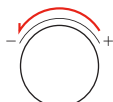

**b** Continue to turn the knob to adjust the cooking time, the maximum time value is "95:00".



**c** Press  to start cooking.



**a** Press  to cook food with 100% power level for 30 seconds. Each press on the same key can increase 30 seconds and the maximum time value is "95:00".



## 9. MULTI-STAGE COOKING

Example: Defrost food for 5 minutes and then cook with 80% microwave power for 7 minutes.

**a** Press  once, "dEF1" will display.



**b** Turn the knob to set the desired defrost time to 5 minutes.



**c** Press  repeatedly until "P80" displays.



**d** Press  to confirm the power level.





- e Turn the knob to set the cooking time to 7 minutes.

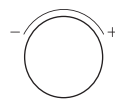

- f Press  START/+30SEC. to start cooking.



**NOTE**

- Two cooking stages can be set in multi-stage cooking.
- If you set the defrost function, it will work automatically in the first stage.
- The kitchen timer, auto menu, and speedy cooking cannot be set as one of the multi-stage.

## 10. AUTO MENU

- a In standby mode, turn the knob right once, and then "A-1" will display.

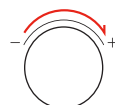

- b Turn the knob repeatedly to choose the menu you need. The 7 auto menus are available.



- c Press  START/+30SEC. to confirm.



- d Turn the knob to set the weight of the food.

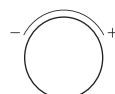

- e Press  START/+30SEC. to start cooking.



## AUTO MENU CHART

MENU	WEIGHT/AMOUNT	DISPLAY	POWER LEVEL
A-1 Popcorn	50g 100g	50g 100g	P100
A-2 Potato	1 (230g) 2 (460g) 3 (690g)	1 2 3	P100
A-3 Pizza	200g 400g	200g 400g	P100
A-4 Frozen Vegetable	200g 300g 400g	200g 300g 400g	P100
A-5 Beverage	1 cup (120ml) 2 cups (240ml) 3 cups (360ml)	1 2 3	P100
A-6 My Plate (Dinner Plate)	250g 350g 500g	250g 350g 500g	P100
A-7 Meat (Pork)	250g 350g 450g	250g 350g 450g	P80

## 11. LOCK FUNCTION FOR CHILDREN

---

You can use this function to prevent children from accidentally turning the oven on.

- a** To activate the lock:  
In standby mode, press and hold  STOP/CANCEL for three seconds. A beep sounds and the locked icon will display.



- b** To deactivate the lock:  
In the locked state, press and hold  STOP/CANCEL for three seconds. A beep sounds.



## 12. INQUIRING FUNCTION

---

- a** When oven is cooking, press  Timer/Clock, the current time will display for three seconds in the display.



- b** In the microwave cooking state, press  Microwave to inquire about the power level. It will display for three seconds.



- c** In the grilling, and combination cooking state, press  Function to inquire about the cooking mode. It will display for three seconds.



# CLEANING AND MAINTENANCE

## CLEANING

With good care and cleaning, your appliance will retain its appearance and remain fully functioning for a long time to come. We will explain here how you should correctly care for and clean your appliance.



**WARNING**

- Scratched glass in the appliance door may develop into a crack. Do not use a glass scraper, sharp or abrasive cleaning aids or detergents.
- The surface of the appliance may become damaged if it is not cleaned properly. Microwave energy may escape. Clean the appliance on a regular basis, and remove any food remnants immediately.
- Do not immerse the appliance in water or clean under a jet of water.

### Cleaning agent

To ensure that the different surfaces are not damaged by using the wrong cleaning agent, observe the information in the table. Wash new sponge cloths thoroughly before use.

#### Do not use:



Harsh or abrasive cleaning agents



Metal or glass scrapers to clean the door panels



Metal or glass scrapers to clean the door seal



Hard scouring pads or sponges



Cleaning agents with a high alcohol content

### APPLIANCE FRONT

#### Hot soapy water:

Clean using a dish cloth and then dry with a soft cloth. Do not use metal or glass scrapers for cleaning.

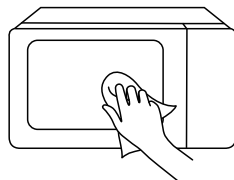

## APPLIANCE FRONT WITH STAINLESS STEEL

---

### Hot soapy water:

Clean using a dish cloth and then dry with a soft cloth. Remove splashes and patches of limescale, grease, starch and albumin immediately. Corrosion can form under these patches or splashes. Do not use glass cleaners or metal or glass scrapers for cleaning.

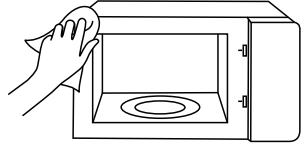

## COOKING COMPARTMENT MADE OF STAINLESS STEEL

---

### Hot soapy water or vinegar solution:

Clean using a dish cloth and then dry with a soft cloth. Do not use oven spray or any other aggressive oven cleaners or abrasive materials. Scouring pads, rough sponges and pan cleaners are also unsuitable. These items scratch the surface. Allow the interior surfaces to dry completely.

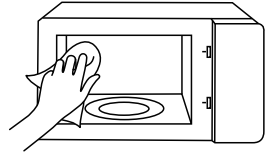

## RECESS IN THE COOKING COMPARTMENT

---

### Damp cloth:

Water must not be allowed to run into the appliance through the turntable drive. Dry the turntable drive with a cloth.

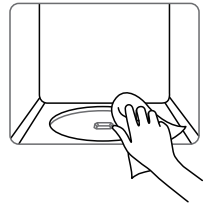

## TURNTABLE AND ROLLER RING

---

### Hot soapy water:

When placing the turntable back into its recess, it must engage properly.

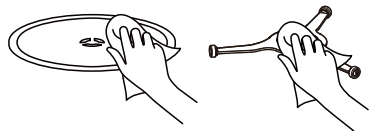

## DOOR PANELS

---

### Glass cleaner:

Clean with a dish cloth. Do not use glass scrapers.

# TROUBLE SHOOTING

Check your problem by using the chart below and try the solutions for each problem.  
If the microwave oven still does not work properly, contact the nearest authorized service center.

TROUBLE	POSSIBLE CAUSE	POSSIBLE REMEDY
Oven will not start	<ul style="list-style-type: none"> <li>a. Electrical cord for oven is not plugged in.</li> <li>b. Door is open.</li> <li>c. Wrong operation is set.</li> </ul>	<ul style="list-style-type: none"> <li>a. Plug into the outlet.</li> <li>b. Close the door and try again.</li> <li>c. Check instructions</li> </ul>
Arcing or sparking	<ul style="list-style-type: none"> <li>a. Materials to be avoided in microwave oven were used.</li> <li>b. The oven is operated when empty.</li> <li>c. Spilled food remains in the cavity.</li> </ul>	<ul style="list-style-type: none"> <li>a. Use microwave-safe cookware only.</li> <li>b. Do not operate with oven empty.</li> <li>c. Clean cavity with soft damp cloth.</li> </ul>
Unevenly cooked foods	<ul style="list-style-type: none"> <li>a. Materials to be avoided in microwave oven were used.</li> <li>b. Food is not defrosted completely.</li> <li>c. Cooking time, power level is not suitable.</li> <li>d. Food is not turned or stirred.</li> </ul>	<ul style="list-style-type: none"> <li>a. Use microwave-safe cookware only.</li> <li>b. Completely defrost food.</li> <li>c. Use correct cooking time, power level.</li> <li>d. Turn or stir food.</li> </ul>
Overcooked foods	<ul style="list-style-type: none"> <li>Cooking time, power level is not suitable.</li> </ul>	<ul style="list-style-type: none"> <li>Use correct cooking time, power level.</li> </ul>
Undercooked foods	<ul style="list-style-type: none"> <li>a. Materials to be avoided in microwave oven were used.</li> <li>b. Food is not defrosted completely.</li> <li>c. Oven ventilation ports are restricted.</li> <li>d. Cooking time, power level is not suitable.</li> </ul>	<ul style="list-style-type: none"> <li>a. Use microwave-safe cookware only.</li> <li>b. Completely defrost food.</li> <li>c. Check to see that oven ventilation ports are not restricted.</li> <li>d. Use correct cooking time, power level</li> </ul>
Improper defrosting	<ul style="list-style-type: none"> <li>a. Materials to be avoided in microwave oven were used.</li> <li>b. Cooking time, power level is not suitable.</li> <li>c. Food is not turned or stirred.</li> </ul>	<ul style="list-style-type: none"> <li>a. Use microwave-safe cookware only.</li> <li>b. Use correct cooking time, power level.</li> <li>c. Turn or stir food.</li> </ul>



According to Waste of Electrical and Electronic Equipment (WEEE) directive, WEEE should be separately collected and treated. If at any time in future you need to dispose of this product please do NOT dispose of this product with household waste. Please send this product to WEEE collecting points where available.



**#DetailsMatter**



 **BEDIENUNGSANLEITUNG**

# **MIKROWELLENOFEN**

MW3-AG25PFI(MG)

Bitte lesen Sie diese Bedienungsanleitung vor der Inbetriebnahme.

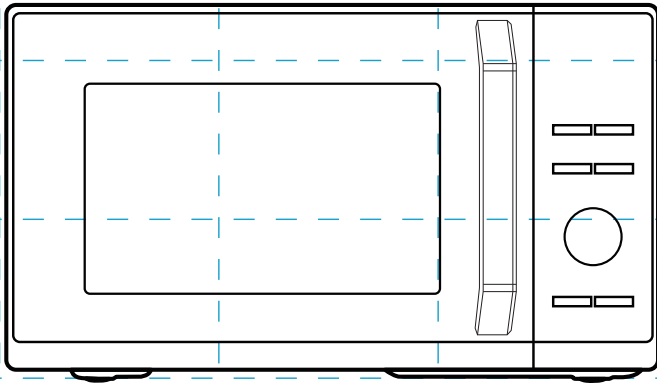

 **TOSHIBA**

# INHALT

## PRODUKTSICHERHEIT

Sicherheitshinweise zum Vermeiden einer möglichen Exposition wegen übermäßiger Mikrowellenenergie .....	DE-01
Technische Daten .....	DE-02
Wichtige Sicherheitshinweise .....	DE-03
Zur Verringerung des Verletzungsrisikos für Personen, die die Installation erten .....	DE-08
Reinigung .....	DE-10
Utensilien .....	DE-11
Materialien, die Sie in der Mikrowelle benutzen können .....	DE-12
Materialien, die nicht im Mikrowellenofen verwendet werden dürfen .....	DE-14

## PRODUKT EINSTELLEN

Aufstellen Ihres Mikrowellenofens .....	DE-15
---	-------

## BEDIENUNGSANLEITUNG

Vor Erstgebrauch .....	DE-18
Betrieb .....	DE-19
Bedienfeld und Funktionen .....	DE-19
1. Uhrzeit einstellen .....	DE-20
2. Einstellen des Küchentimers .....	DE-21
3. Garen im Mikrowellenofen .....	DE-21
4. Grillen .....	DE-22
5. Kombiniertes Kochen .....	DE-23
6. Auftauen nach Zeit .....	DE-24
7. Auftauen nach Gewicht .....	DE-24
8. Schnelles Kochen .....	DE-25
9. Mehrstufiges Garen .....	DE-25

10. Auto-Menü .....	DE-26
11. Kindersicherung .....	DE-28
12. Abfragefunktion .....	DE-28

## REINIGUNG UND PFLEGE

Reinigung .....	DE-29
Problembehebung .....	DE-31



### HINWEIS

LESEN, VERSTEHEN UND BEFOLGEN SIE DIESE ANLEITUNGEN, BEVOR SIE DIESES PRODUKT IN BETRIEB NEHMEN.  
BEWAHREN SIE DIESES HANDBUCH ZUM ZUKÜNFTIGEN NACHSCHLAGEN AUF.

# PRODUKTSICHERHEIT

## SICHERHEITSHINWEISE ZUM VERMEIDEN MÖGLICHER EXPOSITION DURCH ÜBERHÖHTE MIKROWELLENENERGIE

---

(a). Versuchen Sie nicht, den Backofen mit geöffneter Tür zu betreiben, weil Sie dadurch gefährlicher Mikrowellenstrahlung ausgesetzt werden können. Die Sicherheitsverriegelungen dürfen weder umgangen noch modifiziert werden.

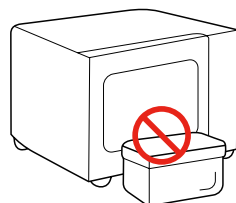

(b). Geben Sie keine Gegenstände in den Bereich zwischen Garraum und Backofentür und verhindern Sie, dass sich Schmutz und/oder Reinigungsmittelrückstände auf der Dichtung ansammeln.

(c). **WARNUNG:** Wenn die Tür oder die Türdichtungen beschädigt sind, darf die Mikrowelle solange nicht betrieben werden, bis sie durch eine kompetente Person repariert wurde.

### ANHANG

---

Wenn das Gerät nicht in einem sauberen Zustand gehalten wird, kann seine Oberfläche beschädigt und die Lebensdauer des Geräts verkürzt werden und möglicherweise können gefährliche Situationen entstehen.

## TECHNISCHE DATEN

---

MODELL	MW3-AG25PFI(MG)
SPANNUNG/FREQUENZ	230-240 V~ 50 Hz
MIKROWELLEN-EINGANGSLEISTUNG	1400 W
MIKROWELLEN-AUSGANGSLEISTUNG	900 W
NENNEINGANGSLEISTUNG (GRILL)	1000-1100 W



### HINWEIS

Alle Bilder in diesem Handbuch dienen nur zur Veranschaulichung. Diese können sich geringfügig von den gekauften Geräten unterscheiden. Bitte beziehen Sie sich auf das tatsächliche Produkt.

# WICHTIGE SICHERHEITSHINWEISE



## WARNUNG

Befolgen Sie bei der Benutzung des Geräts die nachstehend aufgeführten allgemeinen Sicherheitshinweise, um die Gefahr von Feuer, Stromschlag, Verletzungen oder übermäßiger Mikrowellenstrahlung ausgesetzt zu werden, zu reduzieren:



Lesen und befolgen Sie insbesondere:

**„SICHERHEITSHINWEISE  
ZUM VERMEIDEN  
MÖGLICHER EXPOSITION  
DURCH ÜBERHÖHTE  
MIKROWELLENENERGIE“.**



Dieses Gerät kann von Kindern ab 8 Jahren und Personen mit eingeschränkten physischen, sensorischen oder geistigen Fähigkeiten oder unzureichenden Erfahrungen und Kenntnissen benutzt werden, wenn sie beaufsichtigt werden oder sie in die sichere Benutzung des Gerätes eingewiesen worden sind und die mit der Benutzung verbundenen Gefahren verstehen. Kinder dürfen nicht mit dem Gerät spielen. Reinigung und

Benutzerwartung dürfen nicht von Kindern ohne Aufsicht durchgeführt werden.



Halten Sie sowohl das Gerät als auch sein Kabel außerhalb der Reichweite von Kindern unter 8 Jahren.

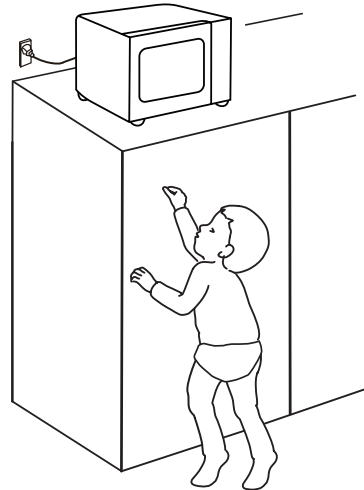

Wenn das Netzkabel beschädigt wurde, muss es entweder vom Hersteller,

# WICHTIGE SICHERHEITSHINWEISE

einem autorisierten Kundendienst oder ähnlich qualifiziertem Personal ausgetauscht werden, um Gefahren vorzubeugen.

---

 **WARNUNG:** Vergewissern Sie sich, dass das Gerät ausgeschaltet ist, bevor Sie die Innenbeleuchtung der Mikrowelle wechseln, um Stromschlag vorzubeugen.

---

 **WARNUNG:** Für Nichtfachleute ist die Ausführung von Wartungs- und Reparaturarbeiten gefährlich, wenn eine vor Mikrowellenstrahlung schützende Abdeckung entfernt wird.

---

 **WARNUNG:** Flüssigkeiten und andere Lebensmittel dürfen nicht in versiegelten Behältern erhitzt werden, da sie explodieren können.

 Lassen Sie den Backofen nicht unbeaufsichtigt, wenn Sie Speisen in Kunststoff- oder Papierbehältern erhitzen, weil diese sich entzünden können.

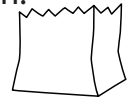

 Benutzen Sie nur für Mikrowellen geeignetes Zubehör.

---

 Wenn Rauch entsteht, schalten Sie das Gerät aus, trennen Sie es vom Stromnetz und lassen Sie die Gerätetür geschlossen, um die Flammen zu ersticken.

---

 Das Erhitzen von Getränken in einer Mikrowelle kann zu einem verzögerten plötzlichen Sieden führen. Seien Sie deshalb bei der Handhabung des Behälters vorsichtig.

---

 Der Inhalt von Nuckelflaschen und Babynahrung in Gläsern muss umgerührt oder geschüttelt werden. Überprüfen Sie vor dem

# WICHTIGE SICHERHEITSHINWEISE

Füttern die Temperatur der Babynahrung, um Verbrennungen vorzubeugen.

 Reinigen Sie die Mikrowelle regelmäßig und entfernen Sie dabei alle Speisereste. Bitte halten Sie den Wellenleiterbereich sauber. Verwenden Sie ein weiches, feuchtes Tuch, um es zu reinigen, wenn sich Speisereste auf dem Wellenleiterbereich oder der Kavität befinden. Wenn Lebensmittelrückstände nicht gereinigt werden, kann dies zu unschädlichen Funkenbildung oder etwas Rauch im Mikrowellenhohlraum führen. Es kann auch zu Verfärbungen des Hohlraums kommen.

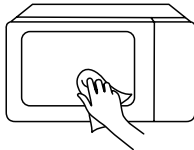

 Verschmutzung kann zur Zerstörung der Oberflächenbeschichtung und in Folge dessen zu einer verkürzten

Lebensdauer des Geräts und damit zu gefährlichen Situationen führen.

 Verwenden Sie nur das für diese Mikrowelle empfohlene Fleischthermometer. (Für Mikrowellen, bei denen ein Temperaturfühler benutzt werden kann.)

 Die Mikrowelle muss mit geöffneter Ziertür betrieben werden. (Für Mikrowellen mit Ziertür.)

 Dieses Gerät ist für die Benutzung im Haushalt und ähnlichen Anwendungen bestimmt, wie beispielsweise:

1. Mitarbeiter-Küchenbereiche in Geschäften, Büros und anderen Arbeitsumgebungen;
2. Durch Kunden in Hotels, Motels und anderen Wohnumgebungen;
3. Bauernhäusern;
4. Umgebungen vom Typ Bed and Breakfast.



# WICHTIGE SICHERHEITSHINWEISE

 Die Mikrowelle ist für das Erhitzen von Speisen und Getränken bestimmt. Das Trocknen von Speisen und Kleidung und das Erhitzen von Wärmekissen, Hausschuhen, Schwämmen, feuchten Tüchern usw. kann zu Verletzungen, Feuer oder Funkenbildung führen.

---

 Die Rückseite des Geräts muss einer Wand zugewandt sein.

---

 Die erreichbaren Oberflächen können während der Benutzung des Geräts heiß sein.

---

 **WARNUNG:** Wenn das Gerät im Modus Kombiniertes Garen betrieben wird, dürfen Kinder den Backofen wegen der entstehenden Temperaturen nur unter Aufsicht von Erwachsenen benutzen.

 Das Gerät ist für eine freistehende Benutzung bestimmt.

---

 Ungeschälte und hartgekochte Eier dürfen nicht in der Mikrowelle erhitzt werden, weil diese selbst dann noch explodieren können, wenn das Erhitzen bereits beendet ist.

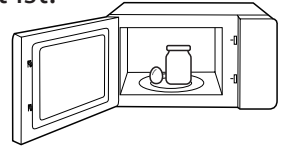

 Die Mikrowelle darf nicht in einen Schrank gestellt werden, es sei denn, sie wurde hierfür getestet.



---

 Speisen- und Getränkebehälter aus Metall dürfen nicht in der Mikrowelle benutzt werden.

---

 Das Gerät darf nicht mit einem Dampfreiniger gereinigt werden.

# WICHTIGE SICHERHEITSHINWEISE

-  Das Gerät ist nicht für den Betrieb mit einer externen Zeitschaltuhr oder einer separaten Fernbedienung vorgesehen.
-  Das Gerät darf nicht hinter einer Außentür eingebaut werden, um einer Überhitzung vorzubeugen. (Ausgenommen Geräte mit Ziertür.)

LESEN SIE ALLE HINWEISE  
AUFMERKSAM DURCH UND  
BEWAHREN SIE SIE FÜR  
ZUKÜNFTIGES NACHSCHLAGEN AUF

# ZUR VERRINGERUNG DES VERLETZUNGSRIKOS FÜR PERSONEN, DIE DIE INSTALLATION ERDEN

Dieses Gerät muss geerdet werden. Bei Kurzschluss verringert die Erdung das Risiko eines Stromschlags, indem sie dem Strom einen Ausweichpfad bietet.

Dieses Gerät ist mit einem Netzkabel ausgestattet, das sowohl einen Erdleiter als auch einen Schutzkontaktstecker besitzt. Der Netzstecker muss in eine Steckdose gesteckt werden, die ordnungsgemäß installiert und geerdet ist.

**WARNUNG** – Bei unsachgemäßer Erdung besteht Stromschlaggefahr. Wenden Sie sich an einen qualifizierten Elektrikerin oder Servicetechnikerin, wenn Sie die Erdungsanleitungen nicht vollständig verstanden haben oder Sie sich nicht sicher sind, ob das Gerät ordnungsgemäß geerdet ist. Wenn Sie ein Verlängerungskabel benutzen müssen, dann benutzen Sie nur ein 3-adriges Verlängerungskabel.



**GEFAHR**

**Stromschlaggefahr:**

Das Berühren einiger der internen Komponenten kann zu schweren oder tödlichen Verletzungen führen. Demontieren Sie das Gerät nicht.

# ZUR VERRINGERUNG DES VERLETZUNGSRIKOS FÜR PERSONEN, DIE DIE INSTALLATION ERDEN



**WARNUNG**

Stromschlaggefahr:

Unsachgemäßer Anschluss der Erdung kann zu Stromschlag führen. Stecken Sie den Netzstecker erst dann in eine Steckdose, wenn das Gerät ordnungsgemäß installiert und geerdet ist.

1. Für das Gerät wird nur ein kurzes Netzkabel mitgeliefert, um die Risiken langer Kabel wie Verheddern oder darüber stolpern zu reduzieren.
2. Wenn ein langes Kabel oder ein Verlängerungskabel verwendet wird:
  - (1). Der elektrische Nennwert des Netz- oder Verlängerungskabels muss mindestens so groß sein wie die elektrische Leistung des Geräts.
  - (2). Das Verlängerungskabel muss ein 3-adriges geerdetes Kabel sein.
  - (3). Ein langes Netzkabel muss so verlegt werden, dass es nicht über Arbeitsplatten oder Tische hängt, wo Kinder daran ziehen können oder man versehentlich darüber stolpern kann.

# REINIGUNG

Trennen Sie das Gerät immer vom Stromnetz, bevor Sie es reinigen.

1. Reinigen Sie den Garraum des Mikrowellenofens nach der Benutzung mit einem leicht angefeuchteten Tuch.
2. Reinigen Sie die Zubehörteile wie gewohnt in Seifenlauge.
3. Türrahmen, Türdichtung und benachbarte Teile müssen bei Verschmutzung sorgfältig mit einem angefeuchteten Tuch gereinigt werden.
4. Verwenden Sie keine scharfen, aggressiven Reiniger oder scharfe Metallkratzer, um das Glas der Tür zu reinigen, weil dadurch die Oberfläche zerkratzt werden kann und dies zum Zerspringen des Glases führen könnte.
5. Reinigungstipp --- Zur leichteren Reinigung der Wände im Garraum, die das gekochte Essen berühren kann: Legen Sie eine halbe Zitrone in eine Schüssel, geben Sie 300 ml Wasser hinzu und erhitzen Sie alles 10 Minuten lang mit 100 % Mikrowellenleistung. Wischen Sie die Mikrowelle anschließend mit einem weichen, trockenen Tuch sauber.

# UTENSILIEN



Verletzungsgefahr:

Für Nichtfachleute ist die Ausführung von Wartungs- und Reparaturarbeiten gefährlich, wenn eine vor Mikrowellenstrahlung schützende Abdeckung entfernt wird. Schlagen Sie unter **„Materialien, die Sie in der Mikrowelle benutzen können“** und **„Materialien, die Sie in der Mikrowelle nicht benutzen dürfen“** nach.

Es kann bestimmte nichtmetallische Gefäße geben, das für die Mikrowelle nicht sicher ist. Im Zweifelsfall können Sie das betreffende Utensil wie folgt testen.

## Utensilientest:



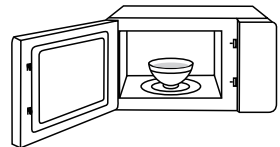



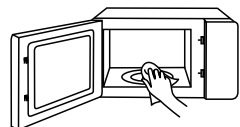









1. Füllen Sie einen mikrowellengeeignetes Behälter mit 1 Tasse kaltem Wasser (250 ml) und legen/stellen Sie das zu testende Kochutensil hinein.
2. Erhitzen Sie bei maximaler Leistung für 1 Minute.
3. Berühren Sie das Utensil vorsichtig. Wenn das Utensil warm ist, dann benutzen Sie es nicht zum Garen in der Mikrowelle.
4. Überschreiten Sie nicht 1 Minute.



HALTEN SIE DEN HOHLRAUM  
UND DEN  
WELLENLEITERBEREICH SAUBER



# MATERIALIEN, DIE SIE IN DER MIKROWELLE BENUTZEN KÖNNEN

UTENSILIEN	ANMERKUNGEN
 Bräter	Befolgen Sie die Anweisungen des Herstellers. Der Boden des Bräters muss sich mindestens 5 mm über dem Drehteller befinden. Bei unsachgemäßer Benutzung kann der Drehteller zerbrechen. 
 Essgeschirr	Nur mikrowellengeeignet. Befolgen Sie die Anweisungen des Herstellers. Benutzen Sie weder zerbrochenes noch gesprungenes Geschirr. 
 Glasbehälter	Entfernen Sie stets den Deckel. Benutzen Sie sie nur zum Aufwärmen von Gerichten. Die meisten Glasbehälter sind nicht hitzebeständig und können springen. 
 Glasgeschirr	Nur hitzebeständiges mikrowellengeeignetes Glasgeschirr. Vergewissern Sie sich, dass keine metallischen Verzierungen vorhanden sind. Benutzen Sie weder zerbrochenes noch gesprungenes Geschirr. 
 Kochbeutel	Befolgen Sie die Anweisungen des Herstellers. Verschließen Sie sie nicht mit Metallverschlüssen. Stechen Sie kleine Löcher in den Kochbeutel, damit entstehender Dampf entweichen kann. 
 Papierteller und -becher	Benutzen Sie sie nur für kurzzeitiges Garen/Aufwärmen. Lassen Sie die Mikrowelle während des Betriebs nicht unbeaufsichtigt. 
 Küchenrollen	Zum Abdecken von Lebensmitteln während des Aufwärmens und um Fett zu absorbieren benutzen. Benutzen Sie sie nur unter Aufsicht für kurzzeitiges Garen. 
 Backpapier	Benutzen Sie es zum Abdecken, um Spritzer zu vermeiden oder um Speisen zum Dünsten einzuwickeln. 

# MATERIALIEN, DIE SIE IN DER MIKROWELLE BENUTZEN KÖNNEN

## UTENSILIEN

## ANMERKUNGEN



Kunststoff

Nur mikrowellengeeignet. Befolgen Sie die Anleitungen des Herstellers. Muss als „mikrowellengeeignet“ gekennzeichnet sein. Einige Kunststoffbehälter werden weich, wenn das darin befindliche Gargut heiß wird. Kochbeutel und fest verschlossene Kunststoffbeutel müssen gemäß den Anleitungen auf der Verpackung geschlitzt, durchbohrt oder belüftet werden.



Frischhaltefolie

Nur mikrowellengeeignet. Benutzen Sie sie zum Abdecken der Speisen während des Garens, um Feuchtigkeit zurückzuhalten. Halten Sie Frischhaltefolie von den Speisen fern.

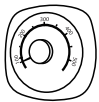

Thermometer

Nur mikrowellengeeignete (Fleisch- und Zuckerthermometer).



Wachspapier

Benutzen Sie es zum Abdecken, um Spritzer zu vermeiden oder Feuchtigkeit zurückzuhalten.





# MATERIALIEN, DIE NICHT IM MIKROWELLENOFEN VERWENDET WERDEN DÜRFEN

## UTENSILIEN

## ANMERKUNGEN



Aluschale

Funken können entstehen. Geben Sie die Speisen in eine mikrowelleneignete Schüssel bzw. auf einen Teller.



Verpackungen aus  
Pappe mit Metallgriff

Funken können entstehen. Geben Sie die Speisen in eine mikrowelleneignete Schüssel bzw. auf einen Teller.



Metallisches oder  
metallbeschichtetes Zubehör

Metall hält die Mikrowellenstrahlung von den Speisen fern. Metallische Verzerrungen können die Ursache für Funkenbildung sein.



Metallische Verschlüsse

Sie können Funken bilden und in der Mikrowelle einen Brand verursachen.



Papiertüten

Sie können sich in der Mikrowelle entzünden.



Schaumstoff

Wenn Schaumstoff hohen Temperaturen ausgesetzt wird, dann kann er schmelzen oder die darin befindliche Flüssigkeit verunreinigen.



Holz

Wenn Holz in der Mikrowelle verwendet wird, trocknet es aus und kann reißen oder sich spalten.



# PRODUKT EINSTELLEN

## AUFSTELLEN IHRES MIKROWELLENOFENS

### BAUTEILE DES MIKROWELLENOFENS UND ZUBEHÖR

Nehmen Sie die Mikrowelle und alle Materialien aus der Verpackung sowie aus dem Garraum der Mikrowelle heraus.

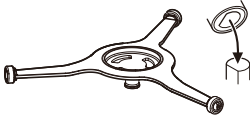

Drehteller

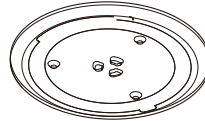

Glasdrehplatte

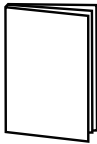

Bedienungsanleitung

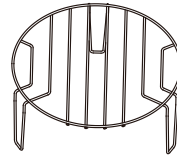

Grillrost (kann nicht in der Mikrowellenfunktion verwendet werden und muss auf die Glasscheibe gestellt werden)

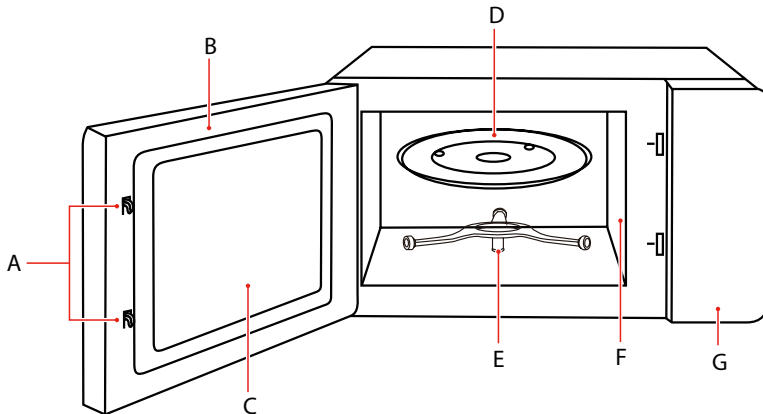

- A) Sicherheitsverriegelung
- B) Tür
- C) Sichtfenster
- D) Glasdrehplatte

- E) Drehteller
- F) Abdeckung Wellenleiter
- G) Bedienfeld



Bei Abweichungen zwischen dem Gerät und den Abbildungen in dieser Anleitung hat das Produkt Vorrang.

# AUFSTELLEN IHRES MIKROWELLENOFENS

## DREHTELLER EINSETZEN

Reinigen Sie den Garraum und setzen Sie den Drehteller ein.

Wenn Sie das Gerät erstmalig aufstellen, vergewissern Sie sich, dass von der Drehtellerwelle alle Verpackungsteile und Transportklebänder entfernt wurden.

Bevor Sie das Gerät das erste Mal für die Zubereitung von Speisen benutzen können, müssen Sie den Drehteller ordnungsgemäß einsetzen. Weiterhin müssen Sie den Garraum und die Zubehörteile reinigen. Sie können sie auch auf den Abschnitt Reinigung verweisen.

Drehteller ordnungsgemäß einsetzen:

1. Setzen Sie den Drehtellerring ② in die Aussparung im Garraum.
2. Setzen Sie den Glasteller ① auf den Drehtellerring ②.

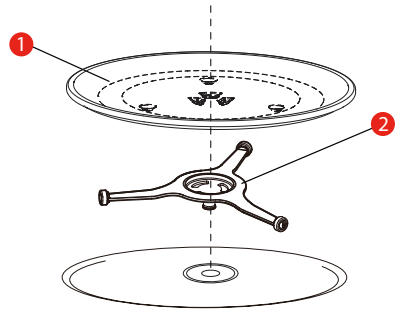

1) Glasdrehplatte  
2) Drehtellerring

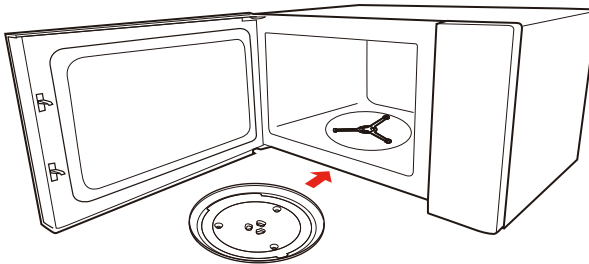

- Benutzen Sie das Gerät niemals ohne Drehteller. Vergewissern Sie sich, dass er ordnungsgemäß eingerastet ist. Der Drehteller kann sich im oder gegen den Uhrzeigersinn drehen.
- Setzen Sie den Drehteller keinesfalls verkehrt herum ein. Der Drehteller muss sich jederzeit frei bewegen können.
- Beim Garen müssen Drehteller und Drehring immer zusammen verwendet werden.
- Alle Nahrungsmittel und Lebensmittelbehältnisse müssen zum Garen auf den Drehteller gestellt/gelegt werden.
- Behindern Sie niemals die Bewegung des Drehtellers.
- Wenn der Drehteller oder der Drehring Risse aufweist oder bricht, wenden Sie sich an den autorisierten Kundendienst.

## AUFSTELLEN AUF DER ARBEITSPLATTE

Entfernen Sie alle Verpackungsmaterialien und Zubehörteile. Überprüfen Sie die Mikrowelle auf Beschädigungen wie Beulen oder eine beschädigte Tür. Stellen Sie die Mikrowelle nicht auf, wenn sie beschädigt ist.

Gehäuse: Entfernen Sie alle Schutzfolien auf dem Gehäuse des Mikrowellenofens. Entfernen Sie nicht die Hohlleiterabdeckung, die zum Schutz des Magnetrans im Garraum angebracht ist.

## AUFSTELLEN

1. Wählen Sie eine ebene Standfläche, die ausreichend Platz für die Lüftungsöffnungen bietet.
  - a. Die Mindestaufstellhöhe beträgt 85 cm.
  - b. Stellen Sie das Gerät mit der Rückseite an eine Wand und lassen Sie einen Mindestabstand von 30 cm über dem Mikrowellenofen. Zwischen dem Mikrowellenofen und angrenzenden Wänden ist ein Mindestabstand von 20 cm erforderlich.
  - c. Entfernen Sie nicht die Standfüße auf der Unterseite der Mikrowelle.
  - d. Das Blockieren der Ein- und/oder Auslassöffnungen kann zur Beschädigung der Mikrowelle führen.
  - e. Stellen Sie die Mikrowelle so weit wie möglich von Radio- und Fernsehgeräten entfernt auf. Der Betrieb der Mikrowelle kann zu Störungen des Radio- oder Fernsehempfangs führen.

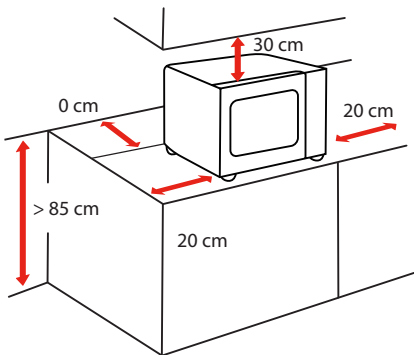

SEITE	ABSTAND CM
Oberseite	30 cm
Links	20 cm
Richtig	20 cm
Dahinter	0 cm
Vorn	Frei

2. Schließen Sie den Mikrowellenofen an einer normalen Haushaltssteckdose an. Vergewissern Sie sich, dass Netzspannung und Netzfrequenz mit den Angaben auf dem Typenschild übereinstimmen.



**HINWEIS**

- Stellen Sie den Mikrowellenofen nicht über einer Herdplatte oder einem anderen wärmeerzeugenden Gerät auf. Wenn Sie den Mikrowellenofen über oder in der Nähe von Wärmequellen aufstellen, kann er beschädigt werden und darüber hinaus erlischt auch die Garantie.

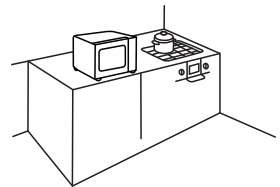

Die Oberfläche des Geräts kann während des Betriebs heiß werden

## VOR ERSTGEBRAUCH

**Es ist normal, dass der Mikrowellenofen unangenehme Gerüche erzeugt, wenn er zum ersten Mal benutzt wird.**

In diesem Abschnitt erfahren Sie, welche Schritte auszuführen sind, bevor Sie Ihre Mikrowelle zum ersten Mal zur Zubereitung von Speisen verwenden. Lesen Sie sich zunächst einmal den Abschnitt „**PRODUKTSICHERHEIT**“ aufmerksam durch.

Bevor Sie Ihr neues Gerät in Betrieb nehmen können, müssen Sie den Drehteller ordnungsgemäß auf dem Antrieb positionieren. Des Weiteren sind der Garraum und die Zubehörteile gründlich zu reinigen.



### HINWEIS

- Benutzen Sie das Gerät niemals ohne Drehteller.
- Vergewissern Sie sich, dass er ordnungsgemäß eingerastet ist. Der Drehteller kann sich im oder gegen den Uhrzeigersinn drehen.

# BETRIEB

## BEDIENFELD UND FUNKTIONEN

---

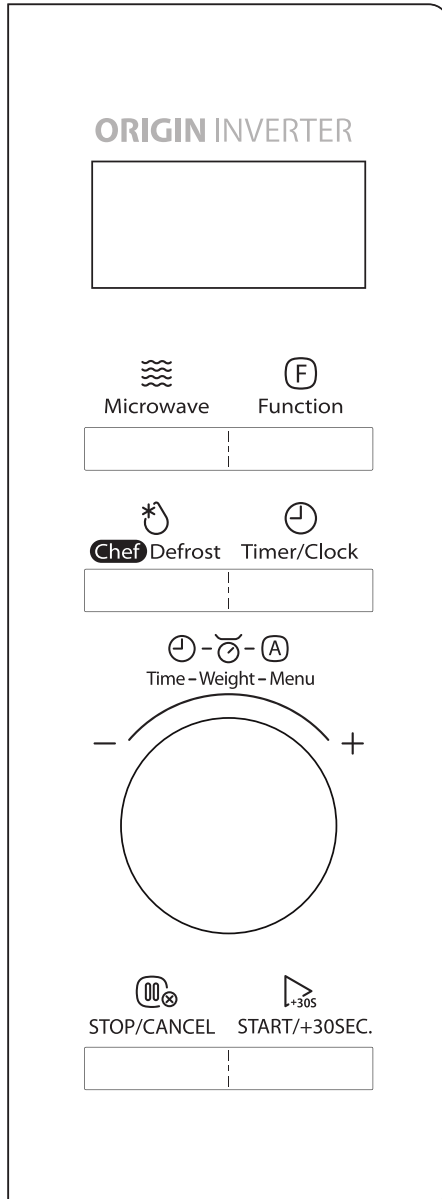

## 1. UHRZEIT EINSTELLEN



---

**a** Drücken Sie zweimal  Timer/Clock, „00:00“ wird angezeigt.

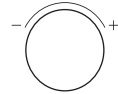

**b** Stellen Sie die Stunden mit dem Drehknopf ein.



**c** Drücken Sie  Timer/Clock oder  START/+30SEC. um die Stundenzahlen zu bestätigen.





oder

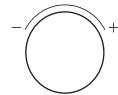

**d** Stellen Sie die Minuten mit dem Drehknopf ein.



**e** Drücken Sie  Timer/Clock oder  START/+30SEC. um zu bestätigen.  
Die Uhrzeit ist eingestellt.



oder



**HINWEIS**

- Die Uhr ist eine 24-Stunden-Anzeige. Wenn die Uhr nicht eingestellt ist, funktioniert sie nicht, wenn die Mikrowelle eingeschaltet ist.
- Um die Uhr zurückzusetzen, wiederholen Sie bitte die Schritte a bis e.

## 2. EINSTELLEN DES KÜCHENTIMERS

- a Drücken Sie einmal  Timer/Clock , „00:00“ wird angezeigt.



- b Stellen Sie mit dem Drehknopf die gewünschte Zeit ein.  
Der maximale Zeitwert ist „95:00“.

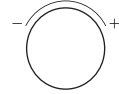

- c Drücken Sie  START/+30SEC. zur Bestätigung.  
Der Timer beginnt herunterzuzählen.



- Der Kurzzeitwecker ist ein Timer.
- Bei aktiviertem Küchentimer kann kein anderes Programm eingestellt werden.

## 3. GAREN IM MIKROWELLENOFEN

Es gibt 10 Leistungsstufen.

STUFE	LEISTUNG	ANZEIGE
1	100 %	P100
2	90 %	P90
3	80 %	P80
4	70 %	P70
5	60 %	P60
6	50 %	P50
7	40 %	P40
8	30 %	P30
9	20 %	P20
10	10 %	P10



Drücken Sie wiederholt  Microwave, um die Leistungsstufe zu wählen.

**a** oder



Drücken Sie einmal  Microwave und stellen Sie dann die Leistungsstufe mit dem Drehknopf ein. 10 Leistungsstufen sind verfügbar.



**b** Drücken Sie  START/+30SEC, um die Leistungsstufe zu bestätigen.



**c** Stellen Sie mit dem Drehknopf die Garzeit ein. Der maximale Zeitwert ist „95:00“.

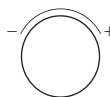

**d** Drücken Sie  START/+30SEC, um die Zubereitung zu starten.



## 4. GRILLEN

---

**a** Drücken Sie einmal  Function, „G-1“ wird angezeigt.



**b** Drücken Sie  START/+30SEC, um den Modus zu bestätigen.



**c** Stellen Sie mit dem Drehknopf die Garzeit ein. Der maximale Zeitwert ist „95:00“.

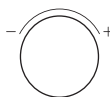

d Drücken Sie , um die Zubereitung zu starten.



**HINWEIS**  • Der Summer ertönt, um Sie daran zu erinnern, die Lebensmittel während des Auftauens zu wenden.  
Falls kein Vorgang stattfindet, setzt der Backofen den Betrieb fort.

## 5. KOMBINIERTES KOCHEN

a Drücken Sie wiederholt , um den gewünschten Zubereitungsmodus zu wählen. „C-1, C-2“ sind verfügbar.  
oder



Drücken Sie einmal  und stellen Sie dann den Zubereitungsmodus mit dem Drehknopf ein.



b Drücken Sie , um den Modus zu bestätigen.



c Stellen Sie mit dem Drehknopf die Garzeit ein.  
Der maximale Zeitwert ist „95:00“.

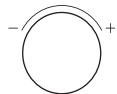

d Drücken Sie , um die Zubereitung zu starten.



### KOMBINIERTE GARTABELLE

FUNKTION	ANZEIGE	MIKROWELLENLEISTUNG	GRILLEISTUNG
Kombiniertes Garen 1	C-1	55 %	45 %
Kombiniertes Garen 2	C-2	36 %	64 %

## 6. AUFTAUEN NACH ZEIT

- a Drücken Sie einmal , damit wird „dEF1“ angezeigt.



- b Stellen Sie mit dem Drehknopf die gewünschte Auftauzeit ein.  
Der maximale Zeitwert ist „95:00“.

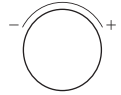

- c Drücken Sie , um das Auftauen zu starten.



**HINWEIS**

- Der Summer ertönt, um Sie daran zu erinnern, die Lebensmittel während des Auftauens umzudrehen. Falls kein Vorgang stattfindet, setzt der Backofen den Betrieb fort.
- Die Auftauleistung beträgt P30 und kann nicht geändert werden.

## 7. AUFTAUEN NACH GEWICHT

- a Drücken Sie  wiederholt, um die Art des Lebensmittels auszuwählen, und dann wird „dEF2“, „dEF3“ oder „dEF4“ angezeigt.



- b Stellen Sie mit dem Drehknopf das Gewicht der Lebensmittel ein, es sollte zwischen „100 g und 2000 g“ liegen.

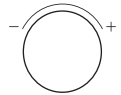

- c Drücken Sie , um das Auftauen zu starten.



LED-ANZEIGE	LEBENSMITTEL	GEWICHT
dEF2	Fleisch	100 g - 2000 g
dEF3	Hähnchen	100 g - 2000 g
dEF4	Fisch	100 g - 2000 g





**HINWEIS**

- Der Summer ertönt, um Sie daran zu erinnern, die Lebensmittel während des Auftauens umzudrehen. Falls kein Vorgang stattfindet, setzt der Backofen den Betrieb fort.

## 8. SCHNELLES KOCHEN

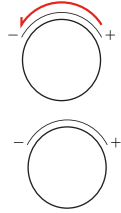
- a** Drehen Sie den Drehknopf nach links, um eine Garzeit bei 100 % Leistung einzustellen.
- b** Stellen Sie die Zubereitungszeit mit dem Drehknopf ein. Der maximale Zeitwert ist „95:00“.
- c** Drücken Sie  „START/+30SEC.“, um die Zubereitung zu starten.



- a** Drücken Sie  „START/+30SEC.“, um die Speisen 30 Sekunden mit 100 % Leistung zu garen. Mit jedem Tastendruck verlängern Sie die Zeit um 30 Sekunden, die Höchstzeit ist „95:00“.



## 9. MEHRSTUFIGES GAREN

Beispiel: Speisen für 5 Minuten auftauen und dann für 7 Minuten mit 80 % Mikrowellenleistung garen.

- a** Drücken Sie einmal  „Chef Defrost“, „dEF1“ wird angezeigt.



- b** Stellen Sie mit dem Drehknopf die gewünschte Auftauzeit auf 5 Minuten ein.



- c** Drücken Sie  „Microwave“ wiederholt, bis „P80“ angezeigt wird.



- d** Drücken Sie  „START/+30SEC.“, um die Leistungsstufe zu bestätigen.



- e Stellen Sie mit dem Drehknopf die Zubereitungszeit auf 7 Minuten ein.

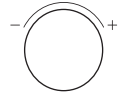

- f Drücken Sie  um die Zubereitung zu starten.



#### HINWEIS

- Zum mehrstufigen Garen können zwei Garstufen eingestellt werden.
- Wenn Sie die Auftaufunktion einstellen, wird sie automatisch in der ersten Stufe ausgeführt.
- Der Küchentimer, das Auto-Menü und die Schnellkochfunktion können nicht als eine von mehreren Stufen eingestellt werden.

## 10. AUTO-MENÜ

- a Drehen Sie im Standby-Modus den Drehknopf einmal nach rechts. Daraufhin wird „A-1“ angezeigt.

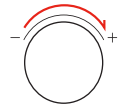

- b Wählen Sie das gewünschte Menü, indem Sie den Drehknopf mehrmals drehen. Es stehen 7 Auto-Menüs zur Verfügung.

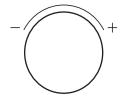

- c Drücken Sie  zur Bestätigung.



- d Stellen Sie mit dem Drehregler das Gewicht der Lebensmittel ein.

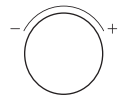

- e Drücken Sie  um die Zubereitung zu starten.



## AUTOMENÜ-TABELLE

MENÜ	GEWICHT/MENGE	ANZEIGE	LEISTUNGSSTUFE
A-1 Popcorn	50 g 100 g	50 g 100 g	P100
A-2 Kartoffeln	1 (230 g) 2 (460 g) 3 (690 g)	1 2 3	P100
A-3 Pizza	200 g 400 g	200 g 400 g	P100
A-4 Gefriergemüse	200 g 300 g 400 g	200 g 300 g 400 g	P100
A-5 Getränke	1 Tasse (120 ml) 2 Tassen (240 ml) 3 Tassen (360 ml)	1 2 3	P100
A-6 Mein Teller (Lunchteller)	250 g 350 g 500 g	250 g 350 g 500 g	P100
A-7 Fleisch (Schwein)	250 g 350 g 450 g	250 g 350 g 450 g	P80

## 11. KINDERSICHERUNG

---

Sie können diese Funktion benutzen, um zu verhindern, dass Kinder den Backofen versehentlich einschalten.

- a** Kindersicherung aktivieren:

Halten Sie im Standby-Modus  für 3 Sekunden gedrückt. Es ertönt ein Signalton und das Sperrsymbol wird angezeigt.



- b** Kindersicherung deaktivieren:

Berühren Und halten Sie  drei Sekunden lang gedrückt, wenn das Gerät gesperrt ist. Es ertönt ein Signalton.



## 12. ABFRAGEFUNKTION

---

- a** Wenn der Ofen gart, drücken Sie . Die aktuelle Uhrzeit wird für drei Sekunden auf dem Display angezeigt.



- b** Drücken Sie im Mikrowellenbetrieb  , um die Leistungsstufe abzufragen. Diese wird 3 Sekunden angezeigt.



- c** Drücken Sie im Betriebszustand Grillen und Kombiniertes Garen  , um den Garmodus abzufragen. Diese wird 3 Sekunden angezeigt.



# REINIGUNG UND PFLEGE

## REINIGUNG

Bei guter Pflege und regelmäßiger Reinigung bleibt Ihnen sowohl das Erscheinungsbild als auch die ordnungsgemäße Funktion Ihres Geräts erhalten. In diesem Kapitel erfahren Sie, wie Sie Ihr Gerät ordnungsgemäß reinigen und pflegen.



- Das zerkratzte Glas der Tür kann u. U. springen. Benutzen Sie weder Glasschaber noch scharfe oder scheuernde Reinigungshilfen oder Reinigungsmittel.
- Werden die Oberflächen des Geräts nicht regelmäßig gereinigt, können sie irreparabel beschädigt werden. Dies kann wiederum dazu führen, dass Mikrowellenenergie aus der Mikrowelle austritt. Unterziehen Sie das Gerät einer regelmäßigen Reinigung und entfernen Sie stets sofort sämtliche Lebensmittelreste aus dem Garraum.
- Tauchen Sie das Gerät nicht in Wasser oder andere Flüssigkeiten und reinigen Sie es nicht unter fließendem Wasser.

### Reinigungsmittel

Folgen Sie den Hinweisen in der Tabelle, damit die verschiedenen Oberflächen nicht durch die Benutzung eines falschen Reinigungsmittels beschädigt werden. Spülen Sie neue Schwämme oder Tücher vor der Benutzung gründlich durch.

**Verwenden Sie keines der nachstehend aufgeführten Mittel:**



Aggressive oder scheuernde  
Reinigungsmittel



Metall- oder Glasschaber zum  
Reinigen der Türverkleidung



Metall- oder Glasschaber zur  
Reinigung der Türdichtung



Harte Topfreiniger  
oder Schwämme



Reinigungsmittel mit  
hohem Alkoholgehalt

### VORDERSEITE DES GERÄTS

#### Heißes Spülwasser:

Reinigen Sie die Oberfläche mit einem leicht angefeuchteten Tuch und trocknen Sie sie anschließend mit einem weichen Tuch ab. Weder Glas- noch Metallschaber für die Reinigung benutzen.

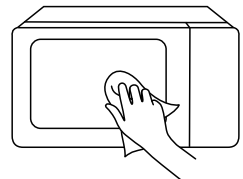



## GERÄTEFRONT MIT EDELSTAHL

---

### Heißes Spülwasser:

Reinigen Sie die Oberfläche mit einem leicht angefeuchteten Tuch und trocknen Sie sie anschließend mit einem weichen Tuch ab. Entfernen Sie Spritzer und Flecken von Kalk, Fett, Stärke und Eiweiß sofort. Oberflächen, die mit Flecken oder Spritzern dieser Art verunreinigt sind, können korrodieren. Weder Glasreiniger noch Glas- oder Metallschaber für die Reinigung benutzen.

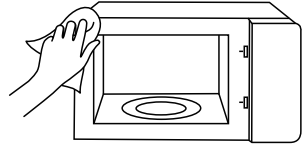

## GARRAUM AUS EDELSTAHL

---

### Heißes Spülwasser oder Essiglösung:

Reinigen Sie die Oberfläche mit einem leicht angefeuchteten Tuch und trocknen Sie sie anschließend mit einem weichen Tuch ab. Weder Ofenspray noch andere aggressive Ofenreiniger oder scheuernde Materialien benutzen. Topfreiniger, raue Schwämme und Pfannenreiniger sind genauso wenig geeignet. Mittel dieser Art führen lediglich zu Kratzern auf den Innenflächen. Lassen Sie die Innenflächen anschließend vollständig trocknen.

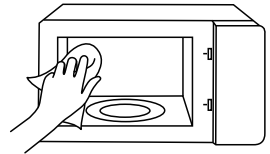

## VERTIEFUNG IM GARRAUM

---

### Angefeuchtetes Tuch:

Es darf unter keinen Umständen Wasser in den Antrieb des Drehtellers gelangen. Trocknen Sie den Antrieb mit einem Tuch ab.

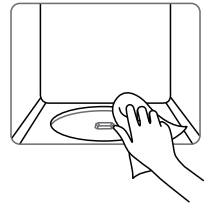

## DREHTELLER UND ROLLENRING

---

### Heißes Spülwasser:

Achten Sie darauf, dass der Drehteller beim Einsetzen in die Vertiefung ordnungsgemäß einrastet.

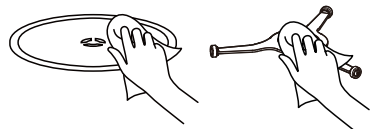

## SICHTSCHEIBE DER GARRAUMTÜR

---

### Glasreiniger:

Mit einem Tuch reinigen. Verwenden Sie keine Glasschaber.

# PROBLEMBEHEBUNG

Überprüfen Sie das Problem anhand der nachstehenden Tabelle und nutzen Sie die Lösungen für jedes Problem.

Wenn der Mikrowellenofen immer noch nicht einwandfrei funktioniert, wenden Sie sich an den autorisierten Kundendienst.

STÖRUNG	MÖGLICHE URSACHE	MÖGLICHE ABHILFE
Der Mikrowellenofen startet nicht	<ul style="list-style-type: none"> <li>a. Der Netzstecker des Mikrowellenofens steckt nicht in der Steckdose.</li> <li>b. Die Tür ist offen.</li> <li>c. Falscher Betrieb eingestellt.</li> </ul>	<ul style="list-style-type: none"> <li>a. Stecken Sie den Netzstecker in eine geeignete Steckdose.</li> <li>b. Schließen Sie die Tür und versuchen Sie es erneut.</li> <li>c. Lesen Sie die Anleitungen</li> </ul>
Lichtbogen- oder Funkenbildung	<ul style="list-style-type: none"> <li>a. Es wurden Materialien verwendet, die im Mikrowellenofen vermieden werden müssen.</li> <li>b. Der Mikrowellenofen wird leer betrieben.</li> <li>c. Verschüttete Lebensmittel bleiben im Garraum.</li> </ul>	<ul style="list-style-type: none"> <li>a. Verwenden Sie nur mikrowellengeeignetes Kochgeschirr.</li> <li>b. Mikrowellenofen nicht leer betreiben.</li> <li>c. Reinigen Sie den Hohlraum mit einem weichen, feuchten Tuch.</li> </ul>
Ungleichmäßig gegarte Speisen	<ul style="list-style-type: none"> <li>a. Es wurden Materialien verwendet, die im Mikrowellenofen vermieden werden müssen.</li> <li>b. Die Lebensmittel sind nicht vollständig aufgetaut.</li> <li>c. Zubereitungszeit, Leistungsstufe ist nicht geeignet.</li> <li>d. Die Speisen werden nicht gewendet oder umgerührt.</li> </ul>	<ul style="list-style-type: none"> <li>a. Verwenden Sie nur mikrowellengeeignetes Kochgeschirr.</li> <li>b. Tauen Sie die Lebensmittel vollständig auf.</li> <li>c. Verwenden Sie die korrekte Zubereitungszeit und Leistungsstufe.</li> <li>d. Wenden oder rühren Sie Lebensmittel um.</li> </ul>
Überkochte Lebensmittel	Zubereitungszeit, Leistungsstufe ist nicht geeignet.	Verwenden Sie die korrekte Zubereitungszeit und Leistungsstufe.
Nicht durchgegartete Speisen	<ul style="list-style-type: none"> <li>a. Es wurden Materialien verwendet, die im Mikrowellenofen vermieden werden müssen.</li> <li>b. Die Lebensmittel sind nicht vollständig aufgetaut.</li> <li>c. Die Belüftungsöffnungen des Mikrowellenofens sind blockiert.</li> <li>d. Zubereitungszeit, Leistungsstufe ist nicht geeignet.</li> </ul>	<ul style="list-style-type: none"> <li>a. Verwenden Sie nur mikrowellengeeignetes Kochgeschirr.</li> <li>b. Tauen Sie die Lebensmittel vollständig auf.</li> <li>c. Vergewissern Sie sich, dass die Lüftungsöffnungen des Mikrowellenofens nicht verschlossen sind.</li> <li>d. Verwenden Sie die korrekte Garzeit und Leistungsstufe</li> </ul>
Unsachgemäßes Auftauen	<ul style="list-style-type: none"> <li>a. Es wurden Materialien verwendet, die im Mikrowellenofen vermieden werden müssen.</li> <li>b. Zubereitungszeit, Leistungsstufe ist nicht geeignet.</li> <li>c. Die Speisen werden nicht gewendet oder umgerührt.</li> </ul>	<ul style="list-style-type: none"> <li>a. Verwenden Sie nur mikrowellengeeignetes Kochgeschirr.</li> <li>b. Verwenden Sie die korrekte Zubereitungszeit und Leistungsstufe.</li> <li>c. Wenden oder rühren Sie Lebensmittel um.</li> </ul>



Gemäß der Richtlinie über die Entsorgung elektrischer und elektronischer Altgeräte (WEEE) müssen diese getrennt gesammelt und entsorgt werden. Wenn Sie dieses Produkt später entsorgen müssen, entsorgen Sie es bitte NICHT über den gewöhnlichen Hausmüll. Bitte bringen Sie dieses Produkt nach Verfügbarkeit zu einer Recyclingstelle für elektrische und elektronische Altgeräte.



**#DetailsMatter**

MANUALE DI ISTRUZIONI

# FORNO A MICROONDE

MW3-AG25PFI(MG)

Rivedere il manuale di istruzioni prima dell'utilizzo.

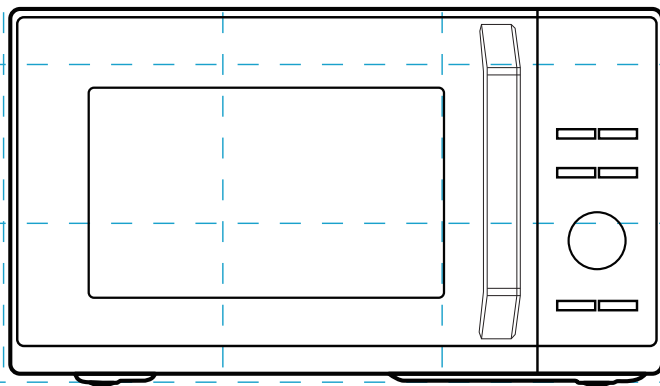

**TOSHIBA**

# INDICE

## SICUREZZA DEL PRODOTTO

Precauzioni per evitare possibili sovraesposizioni alle emissioni del microonde .....	IT-01
Specifiche.....	IT-02
Importanti istruzioni di sicurezza .....	IT-03
Garantire un'adeguata messa a terra dell'impianto per evitare il rischio di lesioni personali ..	IT-08
Pulizia .....	IT-10
Utensili .....	IT-11
Materiali da usare in un forno a microonde .....	IT-12
Materiali che non possono essere usati in un forno a microonde .....	IT-14

## IMPOSTAZIONE DEL PRODOTTO

Installazione del forno .....	IT-15
-------------------------------	-------

## ISTRUZIONI PER L'USO

Operazioni preliminari .....	IT-18
Funzionamento .....	IT-19
Pannello di controllo e caratteristiche .....	IT-19
1. Impostazione dell'orologio .....	IT-20
2. Impostazione del timer di cottura .....	IT-21
3. Cottura al microonde .....	IT-21
4. Cottura alla griglia .....	IT-22
5. Cottura combinata .....	IT-23
6. Scongelamento in base al tempo .....	IT-24
7. Scongelamento in base al peso .....	IT-24
8. Cottura rapida .....	IT-25
9. Cottura multifase .....	IT-25

10. Menu automatico .....	IT-26
11. Funzione di blocco per bambini .....	IT-28
12. Funzione di richiesta .....	IT-28

## **PULIZIA E MANUTENZIONE**

Pulizia .....	IT-29
Risoluzione dei problemi .....	IT-31



**NOTA**

PRIMA DI METTERE IN FUNZIONE IL PRODOTTO,  
LEGGERE, COMPRENDERE E SEGUIRE LE PRESENTI  
ISTRUZIONI.  
CONSERVARE QUESTO MANUALE PER FUTURE  
CONSULTAZIONI.

## SICUREZZA DEL PRODOTTO

### PRECAUZIONI PER EVITARE POSSIBILI ESPOSIZIONI A UNA ECCESSIVA ENERGIA DEL MICROONDE

---

- (a). Non tentare di far funzionare il forno con lo sportello aperto, in quanto ciò può comportare un'esposizione dannosa all'energia delle microonde. È di fondamentale importanza evitare di rompere o manomettere gli interblocchi di sicurezza.
- (b). Non posizionare oggetti tra la parte anteriore del forno e la porta ed evitare l'accumulo di residui e polvere sulle superfici delle guarnizioni.
- (c). **AVVERTENZA:** Se lo sportello o le guarnizioni dello sportello presentano danni, non utilizzare il forno fino a quando una persona qualificata non lo abbia riparato.

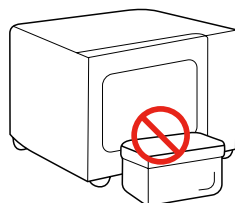

### APPENDICE

---

Se l'apparecchio non viene mantenuto in buone condizioni di pulizia, la sua superficie potrebbe deteriorarsi e compromettere la durata di vita utile dell'apparecchio e portare a situazioni pericolose.



## SPECIFICHE

---

MODELLO	MW3-AG25PFI(MG)
TENSIONE NOMINALE/FREQUENZA	230-240 V~ 50 Hz
POTENZA DI ENTRATA DEL MICROONDE	1400 W
POTENZA DI USCITA DEL MICROONDE	900 W
POTENZA IN INGRESSO (GRILL)	1000-1100 W



Tutte le immagini contenute nel presente manuale sono solo a scopo illustrativo; potrebbero differire leggermente dall'apparecchiatura acquistata; fare riferimento al prodotto effettivo.

# ISTRUZIONI IMPORTANTI SULLA SICUREZZA



## AVVERTENZA

Al fine di ridurre il rischio di incendio, scosse elettriche, lesioni alle persone o esposizione a un'eccessiva emissione di energia del forno a microonde quando si utilizza l'apparecchio, osservare le precauzioni di base, tra cui le seguenti:



Leggere e seguire le specifiche: **"PRECAUZIONI PER EVITARE POSSIBILI SOVRAESPOSIZIONI ALLE EMISSIONI DI MICROONDE"**.



Questo apparecchio può essere utilizzato dai bambini dagli 8 anni in su e da persone con capacità fisiche, sensoriali o mentali ridotte, o prive dell'esperienza o delle conoscenze necessarie, solo se supervisionati o istruiti in merito all'uso sicuro dell'apparecchio e se hanno compreso i rischi che ne derivano. Assicurarsi che i bambini non giochino con l'apparecchio. La pulizia e la manutenzione a carico dell'utente non devono essere eseguite da bambini senza la supervisione di un adulto.



Tenere l'apparecchio e il relativo cavo fuori dalla portata dei bambini di età inferiore a 8 anni.

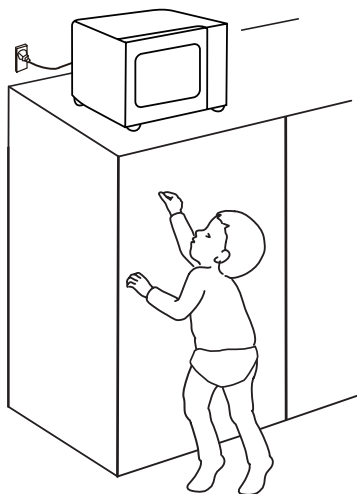

Se il cavo di alimentazione è danneggiato, esso va sostituito dal produttore, un suo agente di

# ISTRUZIONI IMPORTANTI SULLA SICUREZZA

assistenza autorizzato o altro personale qualificato per evitare pericoli.

---

 **AVVERTENZA:** Assicurarsi che l'apparecchio sia spento prima di sostituire la lampada per evitare la possibilità di scosse elettriche.

---

 **AVVERTENZA:** Qualsiasi persona non competente è esposta a pericoli derivanti da interventi di manutenzione o riparazione che implicano la rimozione di una copertura che protegge dall'esposizione alle microonde.

---

 **AVVERTENZA:** Liquidi e altri alimenti non devono essere riscaldati in contenitori sigillati, in quanto possono esplodere.

 Durante il riscaldamento di alimenti in contenitori di plastica o di carta, controllare il forno per evitare che prendano fuoco.

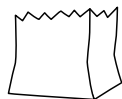

 Utilizzare esclusivamente utensili adatti per essere utilizzati con forni a microonde.

---

 In caso di emissione di fumo, spegnere o scollegare l'apparecchio e tenere lo sportello chiuso per soffocare eventuali fiamme.

---

 Il riscaldamento a microonde delle bevande può provocare un'ebollizione eruttiva ritardata, pertanto occorre prestare attenzione quando si maneggia il recipiente.

---

 Il contenuto di biberon e di vasetti per la pappa deve essere mescolato o agitato, mentre la temperatura

# ISTRUZIONI IMPORTANTI SULLA SICUREZZA

deve essere controllata prima del consumo al fine di evitare ustioni.

- 
-  Il forno deve essere pulito a intervalli regolari rimuovendo eventuali residui di alimenti. Si prega di mantenere pulita l'area della guida d'onda. Utilizzare un panno umido morbido per pulirlo quando ci sono residui di schizzi di cibo sull'area della guida d'onda o sulla cavità. La mancata pulizia dei residui di cibo può causare scintille innocue o fumo nella cavità del microonde, può anche verificarsi scolorimento della cavità.

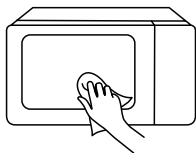

- 
-  Il mancato mantenimento del forno in condizioni pulite potrebbe portare a un deterioramento della superficie con conseguente compromissione della vita

utile dell'apparecchio e a possibili situazioni di pericolo.

- 
-  Usare esclusivamente la sonda di temperatura indicata per il forno. (per i forni predisposti all'utilizzo di una sonda per il rilevamento della temperatura.)

- 
-  Il forno a microonde deve essere utilizzato con il sportello decorativo aperto. (per forni dotati di pannello decorativo.)

- 
-  Questo dispositivo è pensato per uso domestico e per applicazioni simili, come ad esempio:
1. nelle aree cucina dei negozi, degli uffici e altri ambienti di lavoro;
  2. dai clienti di hotel, motel e altri edifici residenziali;
  3. fattorie;
  4. ambienti tipo bed and breakfast.

# ISTRUZIONI IMPORTANTI SULLA SICUREZZA

 Il forno a microonde è destinato al riscaldamento di alimenti e bevande. L'asciugatura di alimenti o indumenti e il riscaldamento di cuscini riscaldanti, pantofole, spugne, panni umidi e simili possono comportare il rischio di lesioni, innesco o incendio.

 La superficie posteriore degli apparecchi deve essere appoggiata a una parete.

 Quando l'apparecchio è in funzione, la temperatura delle superfici accessibili può essere molto alta.

 **AVVERTENZA:** Quando l'apparecchio funziona in modalità combinata, i bambini devono utilizzare il forno solo sotto la supervisione di un adulto a causa delle temperature generate.

 L'apparecchio è destinato ad essere usato in modo indipendente.

 Le uova con il guscio e le uova sode intere non devono essere riscaldate nei forni a microonde in quanto possono esplodere, anche al termine del riscaldamento a microonde.

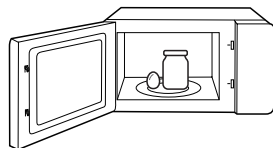



 Evitare di collocare il forno a microonde in un mobile, salvo il caso in cui sia stato testato per tale scopo.

 I recipienti metallici per alimenti e bevande non possono essere utilizzati durante la cottura a microonde.

 L'apparecchio non deve essere pulito con un pulitore a vapore.

# ISTRUZIONI IMPORTANTI SULLA SICUREZZA

 L'apparecchio non è progettato per funzionare con un timer esterno o con un altro sistema di controllo a distanza separato.

 Evitare di installare l'apparecchio dietro pannelli decorativi per evitare il surriscaldamento. (Tale precauzione non è applicabile per apparecchi dotati di pannelli decorativi.)

**LEGGERE ATTENTAMENTE E  
CONSERVARE PER RIFERIMENTI FUTURI**

# GARANTIRE UN'ADEGUATA MESSA A TERRA DELL'IMPIANTO PER EVITARE IL RISCHIO DI LESIONI PERSONALI

Questo elettrodomestico deve essere dotato di messa a terra. In caso di corto circuito elettrico, la messa a terra riduce il rischio di scosse elettriche, grazie alla presenza di un cavo di uscita per la corrente.

Questo elettrodomestico è dotato di cavo con filo e spina di messa a terra. La spina deve essere inserita in una presa correttamente installata e messa a terra.

**ATTENZIONE** - Un uso scorretto della messa a terra può causare il rischio di scosse elettriche. Rivolgersi a un elettricista o a un tecnico qualificato se le istruzioni per la messa a terra non sono state comprese completamente o in caso di dubbi sulla corretta messa a terra dell'apparecchio.

Qualora sia necessario utilizzare una prolunga, utilizzare solamente una prolunga a 3 fili.



**PERICOLO**

Pericolo di Scossa Elettrica:

Toccano i componenti interni, ci si espone al rischio di gravi lesioni personali anche mortali. Non smontare l'elettrodomestico.

# GARANTIRE UN'ADEGUATA MESSA A TERRA DELL'IMPIANTO PER EVITARE IL RISCHIO DI LESIONI PERSONALI



**AVVERTENZA**

Pericolo di Scossa Elettrica:

Un uso scorretto della messa a terra può causare il rischio di scosse elettriche. Non collegare l'elettrodomestico a una presa senza averlo correttamente installato e dotato di messa a terra.

1. Viene fornito un cavo di alimentazione corto per ridurre i rischi dovuti alla possibilità di rimanere impigliati o di inciampare su un cavo più lungo.
2. In caso di utilizzo di un cavo lungo o di una prolunga:
  - (1). La corrente elettrica nominale del cavo o della prolunga in uso deve essere almeno pari a quella nominale dell'elettrodomestico.
  - (2). La prolunga deve essere un cavo a 3 fili con messa a terra.
  - (3). Il cavo più lungo dovrà essere sistemato in modo da non avvolgersi al piano di lavoro o alla superficie del tavolo, dove potrebbe essere staccato da bambini o comunque scollegato involontariamente.



# PULIZIA

Assicurarsi di scollegare l'apparecchio dall'alimentazione.

1. Pulire la cavità del forno dopo l'uso con un panno leggermente umido.
2. Pulire gli accessori come di solito in acqua saponata.
3. Il telaio e la guarnizione dello sportello e le parti adiacenti devono essere puliti accuratamente con un panno umido quando sono sporchi.
4. Evitare l'uso di detergenti abrasivi o di raschietti metallici affilati per pulire il vetro dello sportello del forno, in quanto possono graffiare la superficie e provocare la rottura del vetro.
5. Suggerimento per la pulizia---Per facilitare la pulizia delle pareti della cavità che potrebbero entrare in contatto con gli alimenti cotti: Mettere mezzo limone in una ciotola, aggiungere 300 ml di acqua e riscaldare al 100% di potenza del microonde per 10 minuti. Pulire il forno con un panno morbido e asciutto.

# UTENSILI



## PRECAUZIONI

Rischio di Lesioni Personali:

Qualsiasi persona non competente è esposta a pericoli derivanti da interventi di manutenzione o riparazione che implicano la rimozione di una copertura che protegge dall'esposizione alle microonde. Osservare le istruzioni della sezione **"Materiali da usare in un forno a microonde"** o **"Materiali che non possono essere usati in un forno a microonde"**

Ci sono alcuni utensili non metallici che non possono essere usati con le microonde. In caso di dubbio, è possibile provare l'utensile in questione effettuando la seguente procedura.

## Test dell'utensile:

1. Riempire un recipiente per microonde con 1 tazza di acqua fredda (250 ml) e collocarvi dentro l'utensile.
2. Cuocere con la massima potenza per 1 min.
3. Toccare delicatamente l'utensile. Se l'utensile vuoto è caldo, evitarne l'uso per la cottura a microonde.
4. Non eccedere il tempo di cottura di 1 min.

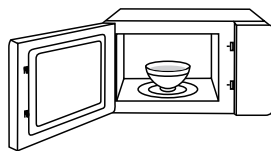





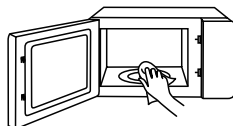











## NOTA

TENERE PULITA LA CAVITÀ E  
L'AREA DELLA GUIDA D'ONDA



# MATERIALI UTILIZZABILI NEL FRONO A MICROONDE

UTENSILI	NOTE
 Piatto di rosolatura	Seguire le istruzioni del produttore. Il fondo del piatto crisp deve trovarsi almeno 5 mm sopra la piattaforma girevole. Un uso scorretto può causare la rottura della piattaforma girevole. 
 Stoviglie	Esclusivamente per microonde. Seguire le istruzioni del produttore. Evitare l'uso di piatti incrinati o scheggiati. 
 Contenitori di vetro	Rimuovere sempre il coperchio. Utilizzare solamente per riscaldare gli alimenti fino a quando non saranno tiepidi. La maggior parte dei contenitori di vetro non sono resistenti al calore e potrebbero rompersi. 
 Oggetti di vetro	Utilizzare solamente oggetti in vetro da forno resistenti al calore. Assicurarsi che non vi siano finiture metalliche. Evitare l'uso di piatti incrinati o scheggiati. 
 Sacchetti per la cottura al forno	Seguire le istruzioni del produttore. Evitare di chiudere la linguetta metallica. Consentire la fuoriuscita del vapore tramite le fessure. 
 Piatti e bicchieri di carta	Usare solo per cuocere o riscaldare vivande per brevi durate. Non lasciare incustodito il forno durante la cottura. 
 Tovaglioli di carta	Coprire gli alimenti per riscaldarli e per l'assorbimento del grasso. Usare solo per cotture di breve durata tenute sotto controllo. 
 Carta da forno	Per la cottura a vapore utilizzare un coperchio o una pellicola per evitare schizzi. 

# MATERIALI UTILIZZABILI NEL FRONO A MICROONDE

## UTENSILI

## NOTE



Plastica

Esclusivamente per microonde. Seguire le istruzioni del produttore. I prodotti in plastica devono riportare la dicitura "Adatto per microonde". Alcuni contenitori in plastica si ammorbidiscono quando le vivande in essi contenute si riscaldano. I "sacchetti da bollitura" e i sacchetti di plastica a chiusura ermetica devono essere forati per garantirne la ventilazione, come indicato sull'etichetta della confezione.



Pellicola

Esclusivamente per microonde. Coprire gli alimenti durante la cottura per conservare l'umidità. Evitare che la pellicola alimentare tocchi gli alimenti.

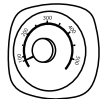

Termometri

Esclusivamente per microonde (termometri per carne e caramelle).



Carta cerata

Utilizzare un coperchio per evitare schizzi e per conservare l'umidità.



# MATERIALI NON UTILIZZABILI NEL FRONO A MICROONDE

## UTENSILI

## NOTE

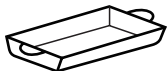

Vassoio di alluminio

Possono causare archi elettrici. Trasferire gli alimenti nel piatto per microonde.



Cartone per alimenti con manico in metallo

Possono causare archi elettrici. Trasferire gli alimenti nel piatto per microonde.



Utensili in metallo o con finiture metalliche

I metalli impediscono l'esposizione delle vivande all'emissione delle microonde. Le finiture metalliche possono causare archi elettrici.



Linguette metalliche flessibili

Potrebbe causare archi elettrici e provocare un incendio nel forno.

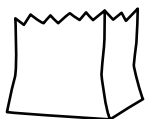

Sacchetti di carta

Ciò potrebbe provocare un incendio nel forno.



Schiuma plastica

La schiuma plastica potrebbe fondersi o contaminare il liquido all'interno se esposta ad alta temperatura.



Legno

Il legno si secca se usato nel forno a microonde e potrebbe spaccarsi o rompersi.



# IMPOSTAZIONE DEL PRODOTTO

## CONFIGURAZIONE DEL FORNO

### NOMI DELLE PARTI E DEGLI ACCESSORI DEL FORNO A MICROONDE -

Rimuovere il forno e tutti i materiali dal cartone e dalla cavità del forno.

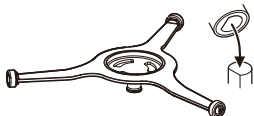

Complesso piattaforma girevole

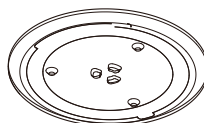

Vassoio di vetro

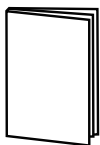

Manuale di istruzioni

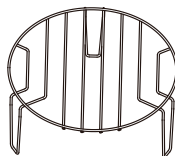

Cestello Griglia (Non può essere utilizzato con la funzione microonde e va collocato sul vassoio di vetro)

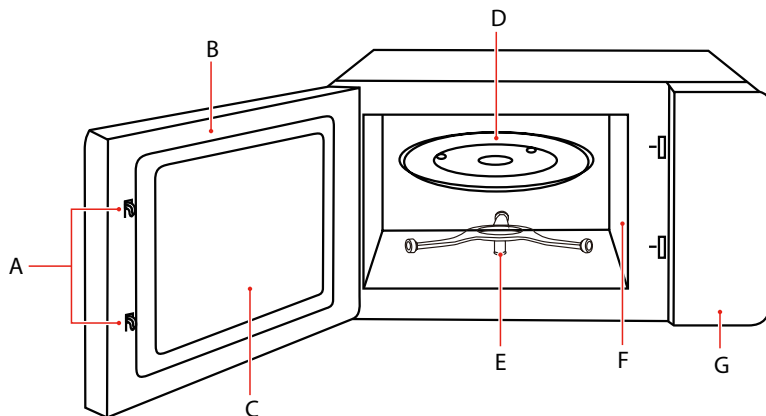

A) Sistema di interblocco di sicurezza

B) Assemblaggio dello sportello

C) Finestra di osservazione

D) Vassoio di vetro

E) Assemblaggio dell'anello del piano girevole

F) Copertura guida d'onda

G) Pannello di controllo



**NOTA**

In caso di divergenze tra l'apparecchio e le immagini nel presente manuale, farà fede il prodotto effettivo.

# CONFIGURAZIONE DEL FORNO

## INSTALLAZIONE PIATTAFORMA GIREVOLE

Pulire il vano di cottura e posizionare la piattaforma girevole.

Per i nuovi impianti, verificare che tutti i materiali di imballaggio e gli adesivi della confezione siano stati rimossi dall'albero del piatto rotante.

Prima di usare per la prima volta l'elettrodomestico per la cottura del cibo, sistemare correttamente il piatto rotante. Pulire il vano di cottura e gli accessori. È possibile anche consultare la sezione dedicata alla loro pulizia.

Sistemazione del piatto rotante:

1. Sistemare il complesso del piatto rotante ② nell'incasso del vano di cottura.
2. Sistemare il vassoio di vetro ① sul complesso del piatto rotante ②.

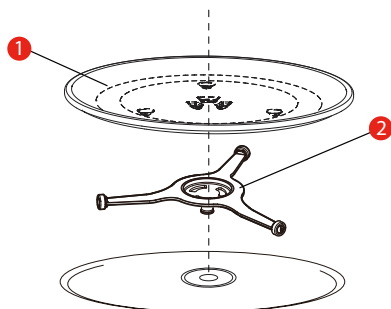

1) Vassoio in vetro

2) Complesso piattaforma girevole

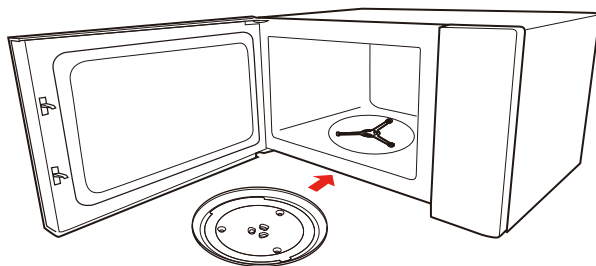

**NOTA**

- Non usare mai l'elettrodomestico senza piatto rotante. Assicurarsi che sia saldamente agganciato. Il piatto può ruotare in senso orario e antiorario.
- Non capovolgere mai il vassoio di vetro. Il vassoio di vetro non deve mai essere ristretto.
- Sia il vassoio di vetro che il complesso della piattaforma girevole devono essere sempre usati durante la cottura.
- Tutti gli alimenti e i loro contenitori devono essere collocati sul vassoio di vetro durante la cottura.
- Non limitare mai i movimenti del piatto rotante.
- Se il vassoio di vetro o il complesso della piattaforma girevole si rompono, contattare immediatamente il centro di assistenza autorizzato più vicino.

## INSTALLAZIONE SUL PIANO DI LAVORO

Rimuovere tutto il materiale di imballaggio e gli accessori. Verificare che il forno non presenti danni come ammaccature o sportello rotto. Evitare l'installazione se il forno è danneggiato.

Mobile: Rimuovere eventuali pellicole protettive presenti sulla superficie del vano del forno a microonde. Non rimuovere il coperchio della guida d'onda che è applicato sulla cavità del forno per proteggerne il magnetrone.

## INSTALLAZIONE

1. Scegliere una superficie piana che fornisca spazio sufficiente per le aperture di aspirazione e/o di scarico dell'aria.
  - a. L'altezza minima di installazione è di 85 cm.
  - b. La superficie posteriore dell'apparecchio deve essere appoggiata a una parete. Lasciare uno spazio di almeno 30 cm al di sopra del forno. Tra il forno e le pareti adiacenti deve essere lasciata uno spazio minimo di 20 cm.
  - c. Non rimuovere le gambe dalla parte inferiore del forno.
  - d. L'ostruzione delle aperture di aspirazione e scarico potrebbe danneggiare il forno.
  - e. Collocare il forno alla massima distanza possibile da radio e televisioni. L'utilizzo del forno a microonde può causare interferenze alla ricezione di radio e televisione.

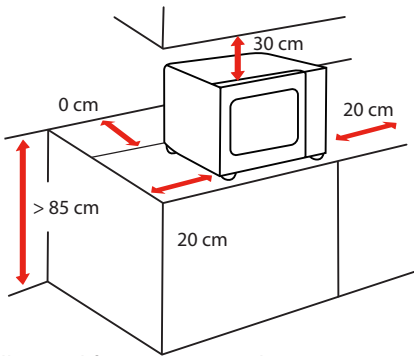

LATO	DISTANZA CM
Parte superiore	30 cm
Sinistra	20 cm
Destra	20 cm
Dietro	0 cm
Anteriore	Aperto

2. Collegare il forno a microonde a una presa elettrica domestica standard. Assicurarsi che la tensione e la frequenza siano uguali alla tensione e alla frequenza sull'etichetta dei dati nominali.



**NOTA**

• Non installare il forno su un piano di cottura o su altri elettrodomestici che producono calore.

Se il forno venisse installato in prossimità di una fonte di calore, potrebbe danneggiarsi e la garanzia non sarebbe più valida.

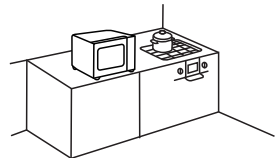

La superficie di accesso potrebbe surriscaldarsi durante il funzionamento



# ISTRUZIONI PER L'USO

## OPERAZIONI PRELIMINARI

**È normale che il forno produca odori sgradevoli al primo utilizzo.**

Questo paragrafo spiega cosa è necessario fare prima di utilizzare il forno a microonde per la prima volta per preparare del cibo. Leggere prima la sezione intitolata "**SICUREZZA DEL PRODOTTO**".

Prima di poter utilizzare il nuovo apparecchio, è necessario posizionare correttamente il piatto rotante. È inoltre necessario pulire il vano cottura e gli accessori.



**NOTA**

- Non usare mai l'elettrodomestico senza piatto rotante.
- Assicurarsi che sia saldamente agganciato. Il piatto può ruotare in senso orario e antiorario.

# FUNZIONAMENTO

## PANNELLO DI CONTROLLO E FUNZIONI

---

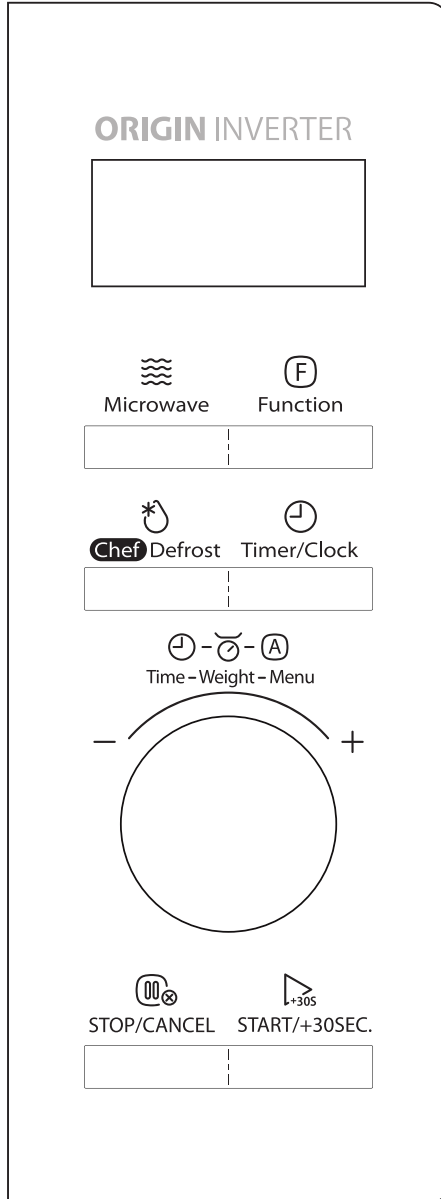

## 1. IMPOSTAZIONE DELL'OROLOGIO

- a** Premere due volte  Timer/Clock, sul display viene visualizzato "00:00".



- b** Ruotare la manopola per impostare le cifre delle ore.

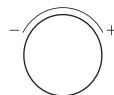

- c** Premere  Timer/Clock o  START/+30SEC. per confermare le cifre dell'ora.





oppure

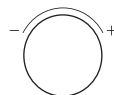

- d** Ruotare la manopola per impostare le cifre dei minuti.



- e** Premere  Timer/Clock o  START/+30SEC. per confermare. L'orologio è stato impostato.



oppure



**NOTA**

- L'orologio viene visualizzato con il formato a 24 ore. Se l'orologio non è impostato, non funzionerà dopo l'accensione.
- Per resettare l'orologio, ripetere dal passaggio a al passaggio e.

## 2. IMPOSTAZIONE DEL TIMER DI COTTURA

**a** Premere una volta  Timer/Clock, "00:00" verrà visualizzato.



**b** Ruotare la manopola per impostare il tempo desiderato. Il massimo valore ammesso è "95:00".

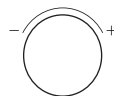

**c** Premere "  START/+30SEC. " per confermare. Il timer inizia il conto alla rovescia.



**NOTA**

- Il Timer di cottura è un conto alla rovescia.
- Non è possibile impostare altri programmi durante il timer di cottura.

## 3. COTTURA AL MICROONDE

Sono disponibili 10 livelli di potenza.

LIVELLO	POTENZA	DISPLAY
1	100%	P100
2	90%	P90
3	80%	P80
4	70%	P70
5	60%	P60
6	50%	P50
7	40%	P40
8	30%	P30
9	20%	P20
10	10%	P10

**a** Premere  Microwave ripetutamente per scegliere il livello di potenza.



**a** oppure  
Premere una volta  Microwave e ruotare la manopola per impostare il livello di potenza.  
Sono disponibili 10 livelli di potenza.



**b** Premere  START/+30SEC. per confermare il livello di potenza.



**c** Ruotare la manopola per impostare il tempo di cottura, il valore di tempo massimo è "95:00".

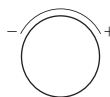

**d** Premere  START/+30SEC. per avviare la cottura.



## 4. COTTURA ALLA GRIGLIA

**a** Premere una volta,  Function "G-1" verrà visualizzato.



**b** Premere  START/+30SEC. per confermare la modalità.



**c** Ruotare la manopola per impostare il tempo di cottura, il valore di tempo massimo è "95:00".

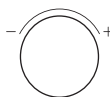

**d** Premere  per avviare la cottura.

  
START/+30SEC.



**NOTA**

• Il cicalino suonerà per ricordare di girare gli alimenti durante la cottura.  
Se non si eseguono operazioni, il forno continua a funzionare.

## 5. COTTURA COMBINATA

**a** Premere  ripetutamente per scegliere la modalità di cottura voluta. "C-1, C-2" sono disponibili.

  
Function

oppure  
Premere una volta , quindi ruotare la manopola per scegliere la modalità di cottura.

  
Function



**b** Premere  per confermare la modalità.

  
START/+30SEC.

**c** Ruotare la manopola per impostare il tempo di cottura, il valore di tempo massimo è "95:00".

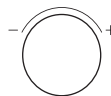

**d** Premere  per avviare la cottura.

  
START/+30SEC.

### TABELLA DI COTTURA COMBINATA

FUNZIONI	DISPLAY	POTENZA DEL MICROONDE	POTENZA GRIGLIA
Combi. 1	C-1	55%	45%
Combi. 2	C-2	36%	64%

## 6. SCONGELAMENTO IN BASE AL TEMPO

**a** Premere una volta  e poi "dEF1" verrà visualizzato sul display.



**b** Ruotare la manopola per impostare il tempo di scongelamento desiderato, il valore di tempo massimo è "95:00".

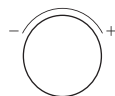

**c** Premere  per avviare lo scongelamento.



**NOTA**

- Il cicalino suonerà per ricordare di girare gli alimenti durante lo scongelamento. Se non si eseguono operazioni, il forno continua a funzionare.
- La potenza di scongelamento è P30 e non può essere modificata.

## 7. SCONGELAMENTO IN BASE AL PESO

**a** Premere  ripetutamente per scegliere il tipo di alimento, quindi verrà visualizzato "dEF2", "dEF3" o "dEF4".



**b** Ruotare la manopola per impostare il peso degli alimenti entro l'intervallo "100 g-2000 g".

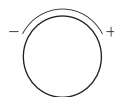

**c** Premere  per avviare lo scongelamento.



DISPLAY LED	CIBO	PESO
dEF2	Carne	100 g-2000 g
dEF3	Pollo	100 g-2000 g
dEF4	Pesce	100 g-2000 g



**NOTA**

- Il cicalino suonerà per ricordare di girare gli alimenti durante lo scongelamento. Se non si eseguono operazioni, il forno continua a funzionare.

## 8. COTTURA VELOCE

- a** Ruotare la manopola verso sinistra per impostare il tempo di cottura con il 100% di potenza.

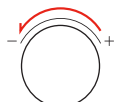

- b** Continuare a ruotare la manopola per regolare il tempo di cottura, il valore di tempo massimo è "95:00".



- c** Premere  per avviare la cottura.

 START/+30SEC.

- a** Premere  per cuocere gli alimenti con il 100% di potenza per 30 secondi. Ad ogni pressione dello stesso tasto l'incremento è di 30 secondi mentre il valore di tempo massimo è di "95:00".

 START/+30SEC.

## 9. COTTURA IN PIÙ FASI

Esempio: Scongelerare gli alimenti per 5 minuti e poi cuocere al microonde all'80% di potenza per 7 minuti.

- a** Premere una volta  "Chef Defrost" e "dEF1" viene visualizzato sul display.

 Chef Defrost

- b** Ruotare la manopola per impostare il tempo di scongelamento di 5 minuti.



- c** Premere  ripetutamente fino a visualizzare "P80".

 Microwave

- d** Premere  per confermare il livello di potenza.

 START/+30SEC.



- e Ruotare la manopola per impostare il tempo di cottura di 7 minuti.

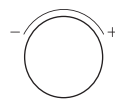

- f Premere  per avviare la cottura.



**NOTA**

- Nella cottura multifase è possibile impostare due fasi di cottura.
- Se si imposta la funzione di scongelamento, quest'ultima verrà attivata automaticamente nella prima fase.
- Il timer di cottura, il menu automatico e la cottura rapida non possono essere impostati come una delle fasi multiple.

## 10. MENU AUTOMATICO

---

- a In modalità standby, ruotando una volta la manopola a destra, comparirà "A-1".

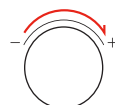

- b Ruotare ripetutamente la manopola per scegliere il menu desiderato. Sono disponibili 7 menu automatici.



- c Premere "  " per confermare.



- d Ruotare la manopola per impostare il peso degli alimenti.

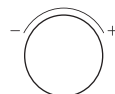

- e Premere  per avviare la cottura.



## TABELLA DEL MENU AUTOMATICO

MENU	PESO/QUANTITÀ	DISPLAY	LIVELLO DI POTENZA
A-1 Popcorn	50 g 100 g	50 g 100 g	P100
A-2 Patate	1 (230 g) 2 (460 g) 3 (690 g)	1 2 3	P100
A-3 Pizza	200 g 400 g	200 g 400 g	P100
A-4 Verdura surgelata	200 g 300 g 400 g	200 g 300 g 400 g	P100
A-5 Bevande	1 tazza (120 ml) 2 tazze (240 ml) 3 tazze (360 ml)	1 2 3	P100
A-6 Il mio piatto (Piatto piano)	250 g 350 g 500 g	250 g 350 g 500 g	P100
A-7 Carne (maiale)	250 g 350 g 450 g	250 g 350 g 450 g	P80

## 11. FUNZIONE DI BLOCCO PER BAMBINI

---

È possibile utilizzare tale funzione per impedire ai bambini di accendere accidentalmente il forno.

**a** Per attivare il blocco:

In modalità standby, tenere premuto  STOP/CANCEL per tre secondi.

Viene emesso un suono acustico e verrà visualizzata l'icona del blocco.



**b** Per disattivare il blocco:

In stato di blocco, tenere premuto  STOP/CANCEL per tre secondi. Viene emesso un suono acustico.



## 12. FUNZIONE DI RICHIESTA

---

**a** Quando il forno è in fase di cottura, premere  Timer/Clock per visualizzare l'ora corrente sul display per tre secondi.



**b** Nello stato di cottura al microonde, premere  Microwave per conoscere il livello di potenza. Verrà visualizzato per tre secondi.



**c** Nella griglia e nello stato di cottura combinata, premere  Function per chiedere informazioni sulla modalità di cottura. Verrà visualizzato per tre secondi.



# PULIZIA E MANUTENZIONE

## PULIZIA

Una buona cura e pulizia consentiranno all'apparecchio di mantenere il suo aspetto e di rimanere perfettamente funzionante per molto tempo. Qui spieghiamo come prendersi cura e pulire correttamente l'apparecchio.



**AVVERTENZA**

- Eventuali graffi sul vetro dello sportello dell'apparecchio possono trasformarsi in crepe.  
Non usare un raschietto per vetri, prodotti per la pulizia taglienti o abrasivi.
- La superficie dell'apparecchio può subire danni se non viene pulita correttamente Causando la fuoriuscita di energia a microonde.  
Pulire regolarmente l'apparecchio e rimuovere immediatamente i resti di cibo.
- Non immergere l'apparecchio in acqua né pulirlo sotto un getto d'acqua.

### Prodotti per la pulizia

Affinché le diverse superfici non vengano danneggiate dall'uso di un detergente inappropriato, osservare le indicazioni della tabella. Lavare bene le spugne nuove prima dell'uso.

#### Non utilizzare:



Detergenti aggressivi o abrasivi



Raschietti per metallo o vetro per pulire i pannelli dello sportello



Raschietti per metallo o vetro per pulire la guarnizione dello sportello



Pagliette o spugnette abrasive



Detergenti ad alto contenuto alcolico

### SPORTELLO DELL'APPARECCHIO

#### Acqua calda e sapone:

Pulire con uno strofinaccio e poi asciugare con un panno morbido. Non usare raschietti di metallo o di vetro per la pulizia.

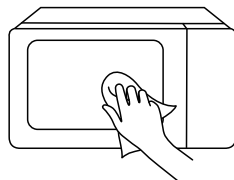

## PARTE ANTERIORE DELL'APPARECCHIO IN ACCIAIO INOX

---

### Acqua calda e sapone:

Pulire con uno strofinaccio e poi asciugare con un panno morbido.

Rimuovere immediatamente schizzi e macchie di calcare, grasso, amido e albumina. La superficie sotto queste macchie o schizzi può corrodersi. Non usare detersivi per vetro o raschietti per metallo o vetro per la pulizia.

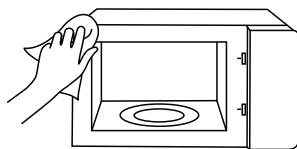

## VANO COTTURA IN ACCIAIO INOX

---

### Acqua calda e sapone o soluzione di aceto:

Pulire con uno strofinaccio e poi asciugare con un panno morbido. Non usare spray per il forno o altri detersivi aggressivi per forno o materiali abrasivi. Non utilizzare pagliette, spugne abrasive e prodotti per la pulizia delle pentole in quanto non idonei. Questi prodotti graffiano la superficie dell'apparecchio. Lasciare asciugare completamente le superfici interne.

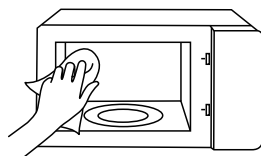

## CAVITÀ DEL VANO COTTURA

---

### Panno umido:

L'acqua non deve penetrare nel meccanismo di rotazione dell'apparecchio. Asciugare il meccanismo di rotazione con un panno.

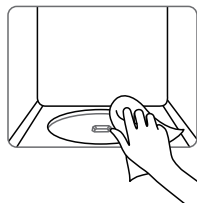

## PIATTO E ANELLO ROTANTE

---

### Acqua calda e sapone:

Quando si rimette il piatto rotante nella sua sede, assicurarsi che si innesti correttamente.

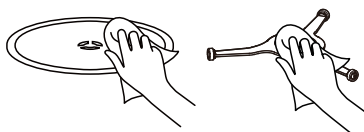

## PANNELLO DELLO SPORTELLO

---

### Detersivo per vetri:

Pulire con uno strofinaccio. Non utilizzare raschietti per vetri.

# RISOLUZIONE DEI PROBLEMI

Controlla il problema utilizzando la tabella sottostante e prova le soluzioni per ognuno di essi.  
Se il forno a microonde continua a non funzionare correttamente, contattare il centro di assistenza autorizzato più vicino.

PROBLEMA	POSSIBILE CAUSA	POSSIBILE RIMEDIO
Il forno non si avvia	a. Il cavo elettrico per il forno non è collegato. b. Lo sportello è aperto. c. È impostato un funzionamento errato.	a. Collegare la spina alla presa. b. Chiudere lo sportello e riprovare. c. Controllare le istruzioni
Archi o scintille	a. Materiali da non utilizzare nel forno a microonde. b. Il forno viene azionato quando è vuoto. c. Il cibo versato rimane nella cavità.	a. Utilizzare solo pentole adatte al microonde. b. Non operare con il forno vuoto. c. Pulire la cavità con un panno umido morbido.
Alimenti cotti in modo non uniforme	a. Materiali da non utilizzare nel forno a microonde. b. Il cibo non viene scongelato completamente. c. Tempo di cottura, livello di potenza non adatto. d. Il cibo non viene girato o mescolato.	a. Utilizzare solo pentole adatte al microonde. b. Scongelare completamente il cibo. c. Utilizzare il tempo di cottura corretto, il livello di potenza. d. Girare o mescolare il cibo.
Alimenti troppo cotti	Tempo di cottura, il livello di potenza non è adatto.	Utilizzare il tempo di cottura corretto, il livello di potenza.
Alimenti poco cotti	a. Materiali da non utilizzare nel forno a microonde. b. Il cibo non viene scongelato completamente. c. Le aperture di ventilazione del forno sono ostruite. d. Tempo di cottura, il livello di potenza non è adatto.	a. Utilizzare solo pentole adatte al microonde. b. Scongelare completamente il cibo. c. Verificare che le aperture di ventilazione del forno non siano ostruite. d. Utilizzare il tempo di cottura corretto, il livello di potenza
Scongelamento improprio	a. Materiali da non utilizzare nel forno a microonde. b. Tempo di cottura, livello di potenza non adatto. c. Il cibo non viene girato o mescolato.	a. Utilizzare solo pentole adatte al microonde. b. Utilizzare il tempo di cottura corretto, il livello di potenza. c. Girare o mescolare il cibo.



Conformemente alla direttiva RAEE (Rifiuti di apparecchiature elettriche ed elettroniche), i RAEE devono essere raccolti e smaltiti separatamente. In caso di necessità futura di smaltire tale prodotto, EVITARE di smaltirlo insieme ai rifiuti domestici. Consegnare il prodotto presso i punti di raccolta RAEE ove presenti.



**#DetailsMatter**



MANUEL D'INSTRUCTIONS

# FOUR À MICRO-ONDES

MW3-AG25PFI(MG)

Consultez le présent guide d'utilisation avant tout emploi.

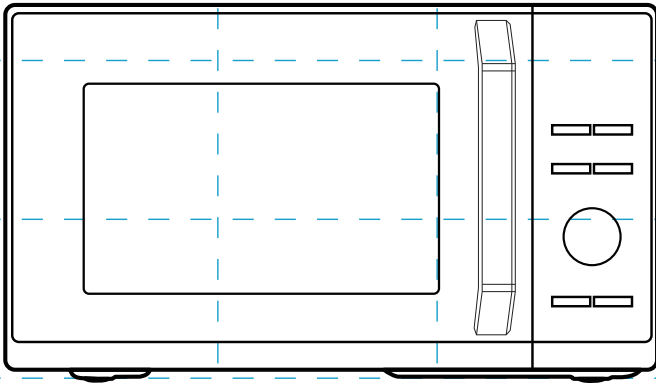

**TOSHIBA**

# SOMMAIRE

## SÉCURITÉ DU PRODUIT

Précautions pour éviter une possible exposition à une énergie excessive des micro-ondes	FR-01
Spécifications	FR-02
Consignes de sécurité importantes	FR-03
Pour réduire le risque de blessure corporelle, connecter l'installation à la terre	FR-08
Nettoyage	FR-10
Ustensiles	FR-11
Matériaux que vous pouvez utiliser dans un four à micro-ondes	FR-12
Matériaux non utilisables dans un four à micro-ondes	FR-14

## RÉGLAGES DU PRODUIT

Installation du four	FR-15
----------------------	-------

## INSTRUCTIONS D'UTILISATION

Avant la première utilisation	FR-18
Fonctionnement	FR-19
Panneau de commande et caractéristiques	FR-19
1. Réglage de l'horloge	FR-20
2. Réglage de la minuterie de cuisine	FR-21
3. Cuisson au micro-ondes	FR-21
4. Cuisson au gril	FR-22
5. Cuisson combinée	FR-23
6. Décongélation par le temps	FR-24
7. Décongélation par le poids	FR-24
8. Cuisson rapide	FR-25
9. Cuisson en plusieurs étapes	FR-25

10. Menu Automatique .....FR-26

11. Fonction de verrouillage pour enfants .....FR-28

12. Fonction d'information .....FR-28

## NETTOYAGE ET ENTRETIEN

Nettoyage .....FR-29

Dépannage .....FR-31



### REMARQUE

AVANT DE FAIRE FONCTIONNER CE PRODUIT, LIRE, COMPRENDRE ET SUIVRE CES INSTRUCTIONS. S'ASSURER DE SAUVEGARDE CE MANUEL POUR Y FAIRE RÉFÉRENCE DANS LE FUTUR.

# SÉCURITÉ DU PRODUIT

## PRÉCAUTIONS POUR ÉVITER L'EXPOSITION POSSIBLE À L'ÉNERGIE MICROONDE EXCESSIVE

---

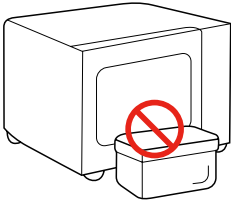
- (a). Ne pas essayer de faire fonctionner ce four avec la porte ouverte, car cela peut entraîner une exposition nocive à l'énergie des micro-ondes. Il est important de ne pas casser ou modifier les interverrouillages de sécurité.
- (b). Ne pas placer un objet entre la face avant et la porte, ou laisser de la saleté ou des résidus de nettoyage s'accumuler sur les surfaces du joint.  
Le diagramme illustre un four à micro-ondes avec sa porte ouverte. Un objet rectangulaire est placé devant la porte, empêchant sa fermeture. Un grand 'X' rouge est superposé sur l'objet, indiquant que cette action est interdite.
- (c). **AVERTISSEMENT** : Si la porte ou les joints de porte sont endommagés, le four ne doit pas être utilisé jusqu'à ce qu'ils aient été réparés par une personne compétente.

### ADDITIF

---

Si l'appareil n'est maintenu en bon état de propreté, ses surfaces peuvent se dégrader, affecter sa durée de vie et entraîner une situation dangereuse.

## SPÉCIFICATIONS

---

MODÈLE	MW3-AG25PFI(MG)
TENSION/FRÉQUENCE NOMINALE	230-240 V~50 Hz
PUISSANCE D'ENTRÉE DU MICRO-ONDES	1400 W
PUISSANCE DE SORTIE DU MICRO-ONDES	900 W
ENTRÉE NOMINALE (GRIL)	1000-1100 W



### REMARQUE

Toutes les images de ce manuel sont fournies à titre indicatif uniquement et peuvent être légèrement différentes de l'équipement acheté, il faut toujours se reporter au produit réel.

# CONSIGNES DE SÉCURITÉ IMPORTANTES



## AVERTISSEMENT

Pour réduire le risque d'incendie, de décharge électrique, blessures ou exposition à une énergie excessive aux micro-ondes lors de l'utilisation de votre appareil, suivez les précautions de sécurité de base, notamment les suivantes :



Lisez et suivez les spécificités :  
« **PRÉCAUTIONS POUR ÉVITER L'EXPOSITION POSSIBLE À L'ÉNERGIE MICROONDE EXCESSIVE** »



Cet appareil peut être utilisé par des enfants de moins de 8 ans ainsi que par des personnes ayant des capacités corporelles, sensorielles ou mentales restreintes ou manquant de connaissances ou d'expériences si elles sont surveillées ou formées sur l'utilisation sûre de l'appareil et sont conscientes des risques encourus. Les enfants ne doivent pas jouer avec l'appareil. Le nettoyage et la maintenance de l'utilisateur ne doivent pas être effectués par des enfants sans supervision.



Gardez l'appareil et son cordon hors de portée des enfants âgés de moins de 8 ans.

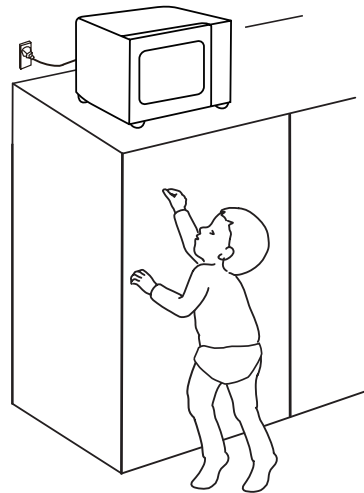

Si le cordon d'alimentation est endommagé, il doit être remplacé par le fabricant, son représentant ou une

# CONSIGNES DE SÉCURITÉ IMPORTANTES

personne qualifiée afin d'éviter tout danger.

---

 **AVERTISSEMENT :** Assurez-vous que l'appareil est éteint avant de remplacer la lampe pour éviter tout risque d'électrocution.

---

 **AVERTISSEMENT :** Les travaux d'inspection ou de réparation qui impliquent la dépose d'un capot qui protège l'exposition aux micro-ondes ne doivent être effectués que par une personne compétente.

---

 **AVERTISSEMENT :** Les liquides et autres aliments ne doivent pas être chauffés dans des récipients fermés, car ces derniers sont susceptibles d'exploser.

---

 Lorsque vous réchauffez des aliments dans des récipients en plastique ou en papier, ayez un regard sur le fourcar il y a risque d'inflammation.

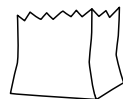

---

 N'utilisez que des ustensiles adaptés aux fours à micro-ondes.

---

 Si de la fumée est émise, éteignez ou débranchez l'appareil et gardez la porte fermée afin d'étouffer les flammes.

---

 Le chauffage par micro-ondes des boissons peut entraîner une ébullition éruptive retardée, c'est pourquoi des précautions doivent être prises lors de la manipulation du récipient.

---

 Le contenu des biberons et des pots pour bébé doit être agité ou secoué et la température contrôlée

# CONSIGNES DE SÉCURITÉ IMPORTANTES

avant consommation, afin d'éviter les brûlures.

 Le four doit être nettoyé régulièrement et tout dépôt d'aliments enlevé. Veillez à ce que la surface du guide d'ondes reste propre. Utilisez un chiffon doux et humide pour nettoyer lorsqu'il y a des résidus de nourriture sur la surface du guide d'ondes ou sur la cavité. Si vous ne nettoyez pas les résidus alimentaires, vous risquez de provoquer des étincelles inoffensives ou de la fumée dans la cavité du four à micro-ondes, ainsi qu'une décoloration de la cavité.

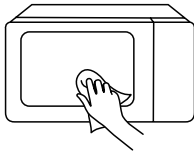

 Ne pas maintenir le four dans un état propre pourrait entraîner une détérioration de la surface qui pourrait nuire à la durée de vie de l'appareil

et éventuellement entraîner une situation dangereuse.

 N'utilisez que la sonde de température recommandée pour ce four. (Pour les fours pourvus d'une possibilité d'utiliser une sonde de détection de température.)

 Le four à micro-ondes doit être utilisé avec la porte décorative ouverte. (Pour les fours avec une porte décorative.)

 Cet appareil est conçu pour une utilisation domestique et des applications similaires, telles que :

1. espaces cuisine dans des magasins, bureaux et autres environnements de travail ;
2. par les clients d'hôtels, de motels et d'autres types de résidences ;
3. exploitations agricoles ;
4. environnements de type chambres d'hôtes.





# CONSIGNES DE SÉCURITÉ IMPORTANTES

 Le four à micro-ondes est conçu pour chauffer des aliments et des boissons. Le séchage d'aliments ou vêtements et le chauffage des coussins chauffants, pantoufles, éponges, chiffons humides et autres peuvent entraîner des risques de blessures, d'inflammation ou d'incendie.

 La surface arrière des appareils doit être placée contre un mur.

 La température des surfaces accessibles peut être élevée lorsque l'appareil est allumé.

 **AVERTISSEMENT :** Lorsque l'appareil fonctionne en mode combiné, les enfants ne doivent utiliser le four que sous la surveillance d'un adulte en raison des températures générées.

 L'appareil est destiné à être utilisé en position autonome.

 Ne chauffez pas les œufs dans leur coquille et es œufs durs entiers dans un four à micro-ondes, le risque de leur éclatement existe même après la cuisson.

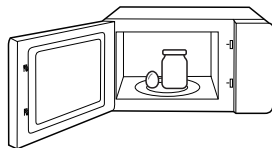



 Le four à micro-ondes ne doit pas être placé dans une armoire à moins d'y avoir été testé.

 Les récipients métalliques destinés à la nourriture et les boissons ne sont pas autorisés pendant la cuisson au four à micro-ondes.

 L'appareil ne doit pas être nettoyé avec un nettoyeur à vapeur.

# CONSIGNES DE SÉCURITÉ IMPORTANTES

 L'appareil n'est pas destiné à être utilisé au moyen d'une minuterie externe ou d'un système de télécommande séparé.

 L'appareil ne doit pas être installé derrière une porte décorative afin d'éviter toute surchauffe.  
(Ceci ne s'applique pas aux appareils doté d'une porte décorative.)

LISEZ-LE ATTENTIVEMENT ET  
CONSERVEZ-LE POUR TOUTE  
RÉFÉRENCE FUTURE

# POUR RÉDUIRE LE RISQUE DE BLESSURE CORPORELLE, CONNECTER L'INSTALLATION À LA TERRE

Cet appareil doit être mis à la terre. En cas de court-circuit, la mise à la terre réduit le risque de décharge électrique en fournissant un fil de courant vers la terre.

Cet appareil est équipé avec un cordon ayant un conducteur de mise à la terre. La fiche doit être branchée dans une prise correctement installée et mise à la terre.

**ATTENTION** — Une mauvaise utilisation de la mise à la terre peut entraîner un risque d'électrocution. Consultez un électricien qualifié ou un réparateur si les consignes de mise à la terre ne sont pas parfaitement comprises ou si un doute plane quant à la bonne mise à la terre de l'appareil.

S'il est nécessaire d'utiliser une rallonge, n'en utiliser qu'une de 3 fils.



Danger d'électrocution :  
Toucher des composants internes peut causer de graves blessures corporelles ou le décès. Il ne faut pas démonter cet appareil.

# POUR RÉDUIRE LE RISQUE DE BLESSURE CORPORELLE, CONNECTER L'INSTALLATION À LA TERRE



## AVERTISSEMENT

Danger d'électrocution :

La mauvaise utilisation de la terre peut entraîner une décharge électrique. Ne pas brancher à une prise de courant tant que l'appareil n'est pas installé correctement et mis à la terre.

1. Le fil d'alimentation est court pour réduire le risque de le coincer ou de trébucher dessus s'il est plus long.
2. Si vous utilisez un long cordon ou une rallonge :
  - (1). La capacité électrique du fil ou de la rallonge doit être au moins aussi grande que la capacité de l'appareil.
  - (2). La rallonge doit être à 3 fils avec une mise à la terre.
  - (3). Un long fil d'alimentation doit être mis de façon à ne pas dépasser du comptoir ou de la table d'où il peut être tiré par des enfants ou faire trébucher.

# NETTOYAGE

S'assurer de débrancher l'appareil de la prise de courant.

1. Nettoyer l'intérieur du four après l'utilisation d'un chiffon humide.
2. Nettoyer les accessoires de la façon habituelle dans l'eau savonneuse.
3. Le châssis de porte et le joint, ainsi que les parties environnantes doivent être soigneusement nettoyés avec un chiffon mouillé quand ils sont sales.
4. Ne pas utiliser de nettoyeurs abrasifs ou de grattoir métallique pour nettoyer la vitre du four, car cela peut rayer la surface ce qui peut fendre le verre.
5. Conseil de nettoyage - Pour nettoyer plus facilement les parois que les aliments ont touchées : Placez un demi-citron dans un bol, ajoutez 300 ml (1/2 pinte) d'eau et chauffez à 100% de puissance au micro-ondes pendant 10 minutes. Essuyez le four avec un chiffon doux et sec.

# USTENSILES



Danger de blessure corporelle :  
Les travaux d'inspection ou de réparation qui impliquent la dépose d'un capot qui protège l'exposition aux micro-ondes ne doivent être effectués que par une personne compétente. Voir les instructions dans « **Matériaux que vous pouvez utiliser dans un four à micro-ondes** » ou « **Matériaux non utilisables dans un four à micro-ondes** ».

Certains ustensiles non métalliques ne peuvent pas être utilisés en toute sécurité au micro-ondes. En cas de doute, vous pouvez tester l'ustensile en question en procédant de la façon suivante.

## Test d'ustensile :



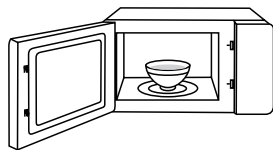



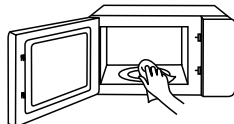









1. Remplir un conteneur à microonde avec 250 ml d'eau froide et y déposer l'ustensile.
2. Cuisson à puissance maximale pendant 1 minute.
3. Toucher doucement l'ustensile. Si l'ustensile vide est chaud, il ne faut pas l'utiliser pour la cuisson aux micro-ondes.
4. Ne dépassez pas 1 minute de cuisson.



MAINTENEZ LA CAVITÉ ET  
LA SURFACE DU GUIDE  
D'ONDES PROPRES

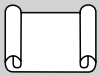

# MATÉRIAUX QUE VOUS POUVEZ UTILISER DANS UN FOUR À MICRO-ONDES

USTENSILES	REMARQUES	
 Plat à rôtir	Suivre les instructions du fabricant. Le fond du plat doit être à au moins 3/16 pouce (5 mm) au-dessus du plateau tournant. Un mauvais usage peut briser le plateau.	
 Vaisselle	Compatible avec les micro-ondes uniquement. Suivre les instructions du fabricant. N'utilisez pas de plats fissurés ou abimés.	
 Pots en verre	Retirez toujours le couvercle. Utilisez uniquement pour réchauffer les aliments. La plupart des pots en verre ne résistent pas à la chaleur et peuvent se briser.	
 Verrerie	Verrerie de four résistante à la chaleur uniquement. Assurez-vous qu'ils n'ont pas de garniture métallique. N'utilisez pas de plats fissurés ou abimés.	
 Sacs de cuisson pour four	Suivre les instructions du fabricant. Ne pas fermer avec un couvercle métallique. Faites des fentes pour permettre l'échappement de la vapeur.	
 Assiettes et tasses en papier	N'utiliser que pour la cuisson ou réchauffage court. Ne pas laisser la cuisson sans surveillance.	
 Serviettes en papier	Sert à couvrir les aliments pour les réchauffer et absorber les graisses. À utiliser sous surveillance pour une cuisson courte.	
 Papier parchemin	À utiliser comme couvercle pour éviter les éclaboussures ou comme enveloppe pour la cuisson à la vapeur.	

# MATÉRIAUX QUE VOUS POUVEZ UTILISER DANS UN FOUR À MICRO-ONDES

## USTENSILES

## REMARQUES



Plastique

Compatible avec les micro-ondes uniquement. Suivre les instructions du fabricant. Doit être étiqueté « Micro-ondes sans risque ». Certains conteneurs en plastique s'amollissent quand les aliments deviennent chauds. Les sacs à bouillir et les sacs en plastique fermés doivent être fendus, percés ou ventilés comme indiqué sur l'emballage.



Enveloppe en plastique

Compatible avec les micro-ondes uniquement. À utiliser pour couvrir les aliments pendant la cuisson pour retenir l'humidité. Ne laissez l'emballage plastique toucher les aliments.

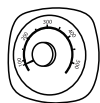

Thermomètres

Uniquement compatible avec les micro-ondes(thermomètres à viande ou bonbons).













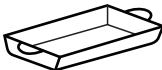



Papier ciré

Sert de couverture pour éviter les éclaboussures et conserver l'humidité.

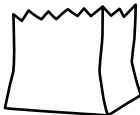



# MATÉRIAUX NON UTILISABLES DANS UN FOUR À MICRO-ONDES

USTENSILES	REMARQUES	
 Plateau en aluminium	Peut provoquer un arc électrique. Il faut transférer les aliments dans un plat allant aux micro-ondes.	
 Carton alimentaire avec poignée métallique	Peut provoquer un arc électrique. Il faut transférer les aliments dans un plat allant aux micro-ondes.	
 Ustensiles en métal ou parés de métal	Le métal protège les aliments contre l'énergie dégagée par le micro-ondes. Les garnitures métalliques provoquent les arcs.	
 Attaches torsadées en métal	Peut provoquer un arc électrique et entraîner un incendie dans le four.	
 Sacs en papier	Peut provoquer un incendie dans le four.	
 Mousse en plastique	La mousse plastique peut fondre ou contaminer le liquide à l'intérieur lorsqu'elle est exposée à des températures élevées.	
 Bois	Le bois séchera quand il est utilisé dans le four à micro-ondes et peut être fragmenté ou craquer.	

# RÉGLAGES DU PRODUIT

## INSTALLATION DU FOUR

### NOMS DES PIÈCES ET ACCESSOIRES DU FOUR À MICRO-ONDES

Retirez le four et tous les matériaux du carton, également de sa cavité .

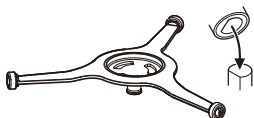

Assemblage De L'Anneau Du Plateau Tournant

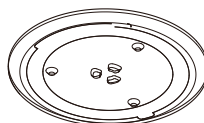

Plateau en verre

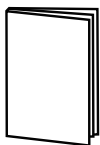

Manuel d'instructions

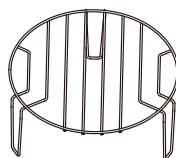

Grille (ne peut pas être utilisée avec la fonction micro-ondes et doit être placée sur le plateau en verre)

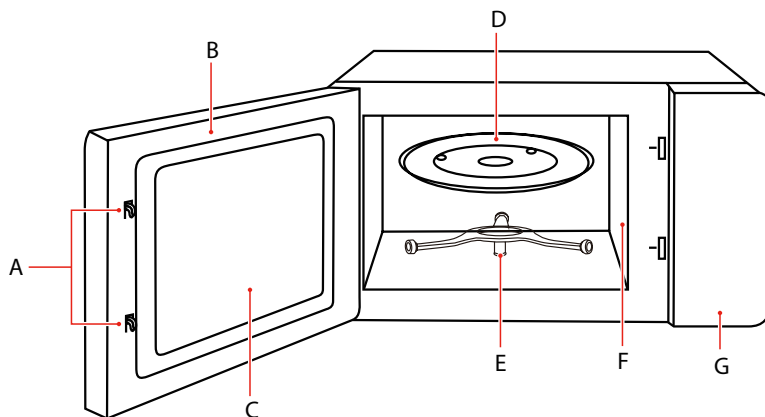

- A) Système de verrouillage de sécurité
- B) Assemblage de la porte
- C) Fenêtre d'observation
- D) Plateau en verre

- E) Assemblage de l'anneau du plateau tournant
- F) Couverture du guide d'ondes
- G) Panneau de commande

  
**REMARQUE**

En cas de différences entre l'appareil et les images dans ce manuel, l'appareil prévaut.

# INSTALLATION DU FOUR

## INSTALLATION DU PLATEAU TOURNANT

Nettoyez le compartiment de cuisson et placez le plateau tournant.

Pour les nouvelles installations, s'assurer que tous les éléments emballages et le ruban d'expédition ont été retirés de l'arbre du plateau tournant.

Avant d'utiliser l'appareil pour préparer des aliments et à la première utilisation, mettre correctement en place le plateau tournant. Nettoyer le compartiment de cuisson et les accessoires. Vous pouvez également les renvoyer à la section «nettoyage».

Mise en place du plateau tournant :

1. Placez l'assemblage de l'anneau du plateau tournant ② dans son emplacement de l'espace de cuisson.
2. Placer le plateau en verre ① sur l'ensemble de l'anneau du plateau tournant ②.

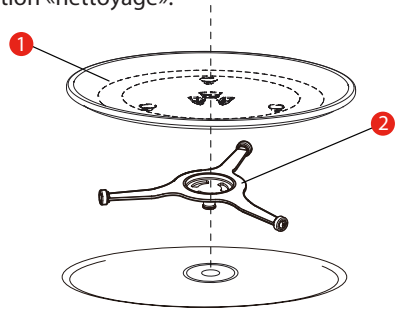

1) Plateau en verre

2) Ensemble anneau du plateau tournant

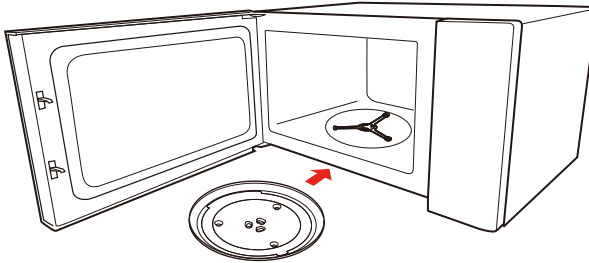

- Ne jamais utiliser l'appareil sans le plateau tournant. S'assurer qu'il est correctement en place. Le plateau tourne dans le sens horaire ou antihoraire.
- Ne placez jamais le plateau en verre à l'envers. Le plateau en verre ne doit jamais être limité.
- Le plateau en verre et l'anneau du plateau tournant doivent toujours être utilisés pendant la cuisson.
- Tous les aliments et récipients doivent toujours être placés sur le plateau en verre pour la cuisson.
- Ne pas coincer le mouvement du plateau tournant.
- Si le plateau en verre ou l'anneau rotatif se fissure ou se brise, contactez le centre de service agréé le plus proche.

## INSTALLATION SUR COMPTOIR

Retirez tous les matériaux d'emballage et les accessoires. Examinez le four pour les dommages tels que bosses ou porte cassée. Il ne faut pas installer le four s'il est endommagé.

Armoire : Retirez tout film protecteur sur la surface de l'armoire du four à micro-ondes. Ne pas retirer le couvercle du guide d'ondes qui est fixé à la cavité du four pour protéger le magnétron.

## INSTALLATION

- Sélectionner une surface de niveau ayant assez d'espace pour les événements d'entrée ou de sortie.
  - La hauteur minimale d'installation est 85 cm.
  - La surface arrière de l'appareil doit être placée contre un mur, en laissant un espace minimum de 30 cm au-dessus du four. Un espace minimal de 20cm est requis entre le four et tout mur adjacent.
  - Ne pas retirer les pieds de la base du four.
  - Le blocage des ouvertures d'entrée ou de sortie peut endommager le four.
  - Placez le four aussi loin possible des postes radio et télé. Les opérations du four à micro-ondes peuvent interférer avec la réception de radio ou télé.

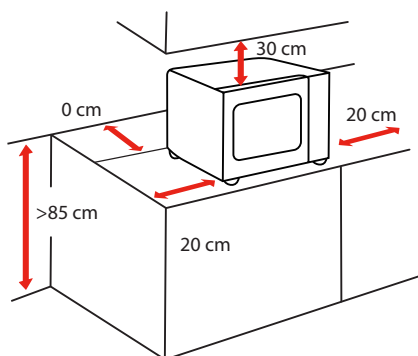

CÔTÉ	DISTANCE (CM)
Haut	30 cm
Gauche	20 cm
Droite	20 cm
Derrière	0 cm
Avant	Ouvrir

- Branchez le four à micro-ondes dans une prise secteur. Assurez-vous que la tension et la fréquence sont les mêmes que celles sur la plaque signalétique.



- N'installez pas le four au-dessus d'une plaque de cuisson ou d'un autre appareil produisant de la chaleur. S'il est installé à proximité ou au-dessus d'une source de chaleur, le four pourrait être endommagé et la garantie annulée.

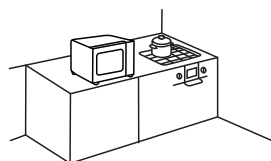

La surface accessible peut être chaude pendant les opérations

# INSTRUCTIONS D'UTILISATION

## AVANT LA PREMIÈRE UTILISATION

**Il est normal que le four dégage des odeurs désagréables lors de sa première utilisation.**

Cette section vous explique ce que vous devez faire avant d'utiliser votre four à micro-ondes lors de préparation des aliments pour la première fois. Lisez au préalable la section « **SÉCURITÉ DU PRODUIT** ».

Avant de pouvoir utiliser votre nouvel appareil, vous devez mettre le plateau tournant correctement en place. Vous devez également nettoyer le compartiment de cuisson et les accessoires.



### REMARQUE

- Ne jamais utiliser l'appareil sans le plateau tournant.
- S'assurer qu'il est correctement en place. Le plateau tourne dans le sens horaire ou antihoraire.

# FONCTIONNEMENT

## PANNEAU DE COMMANDE ET CARACTÉRISTIQUES

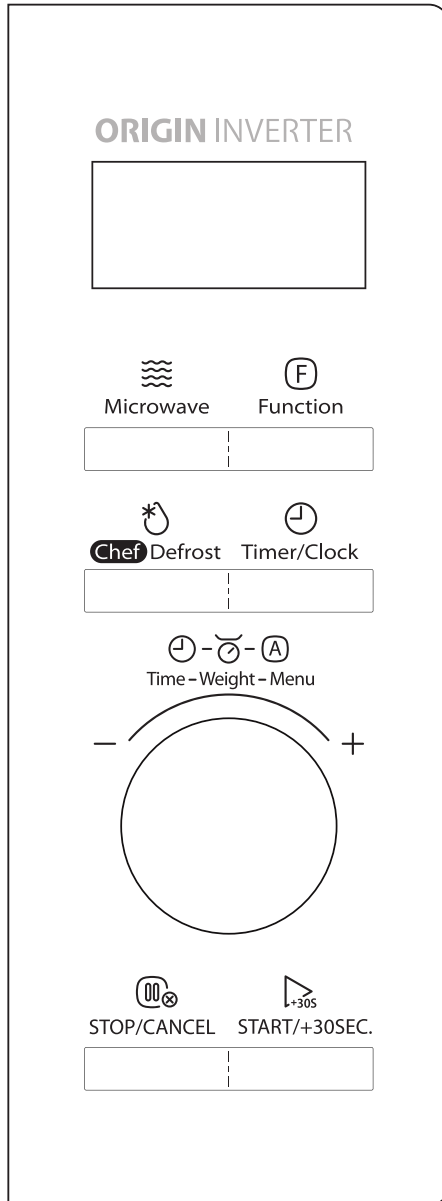

## 1. RÉGLAGE DE L'HORLOGE

---

**a** Appuyez deux fois sur  Timer/Clock, « 00:00 » apparaîtra.



**b** Tournez le bouton pour régler les heures.

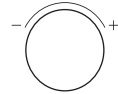

**c** Appuyez sur  Timer/Clock ou  START/+30SEC. pour confirmer les chiffres de l'heure.



ou



**d** Tournez le bouton pour régler les minutes.

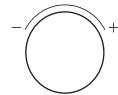

**e** Appuyez sur  Timer/Clock ou  START/+30SEC. pour confirmer. L'horloge est réglée.



ou



- L'horloge a un format d'affichage de 24 heures. Si l'horloge n'est pas réglée, l'appareil ne fonctionnera pas lorsqu'il sera alimenté.
- Pour réinitialiser l'horloge, répétez les étapes a à e.

## 2. RÉGLAGE DE LA MINUTERIE DE CUISINE

a Appuyez une fois sur  Timer/Clock, « 00:00 » apparaîtra.



b Tournez le bouton pour régler la durée souhaitée.  
La durée maximale est « 95:00 ».

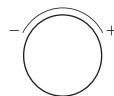

c Appuyez sur  START/+30SEC. pour confirmer. Le minuteur commence un compte à rebours.



- Le minuteur de cuisine est un minuteur.
- Aucun autre programme ne peut être réglé pendant la minuterie de cuisine.

## 3. CUISSON AU MICRO-ONDES

10 niveaux de puissance sont disponibles.

NIVEAU	PUISSANCE	AFFICHAGE
1	100%	P100
2	90%	P90
3	80%	P80
4	70%	P70
5	60%	P60
6	50%	P50
7	40%	P40
8	30%	P30
9	20%	P20
10	10%	P10



**a** Appuyez à plusieurs reprises sur  Microwave pour choisir le niveau de puissance.

**ou**

Appuyez une fois sur  Microwave et tournez le bouton pour régler le niveau de puissance. 10 niveaux de puissance sont disponibles.



**b** Appuyez sur  START/+30SEC. pour confirmer le niveau de puissance.



**c** Tournez le bouton pour régler le temps de cuisson, la valeur maximale du temps est « 95:00 ».

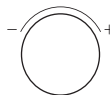

**d** Appuyez sur la touche  START/+30SEC. pour démarrer la cuisson.



## 4. CUISSON AU GRIL

---

**a** Appuyez une fois sur  Function, « G-1 » apparaîtra.



**b** Appuyez sur  START/+30SEC. pour confirmer le mode.



**c** Tournez le bouton pour régler le temps de cuisson, la valeur maximale du temps est « 95:00 ».



**d** Appuyez sur la touche  pour démarrer la cuisson.



• L'avertisseur sonore retentira pour vous rappeler de retourner les aliments pendant la cuisson.  
S'il n'y a pas d'opération, le four continue de fonctionner.

## 5. CUISSON COMBINÉE

**a** Appuyez sur  à plusieurs reprises pour choisir le mode de cuisson souhaité. « C-1, C-2 » sont disponibles.



**ou**  
Appuyez une fois sur , et tournez le bouton pour choisir le mode de cuisson.



**b** Appuyez sur  pour confirmer le mode.



**c** Tournez le bouton pour régler le temps de cuisson, la valeur maximale du temps est « 95:00 ».

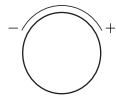

**d** Appuyez sur la touche  pour démarrer la cuisson.



### GRAPHIQUE DE CUISSON COMBINÉE

FUNCTION	AFFICHAGE	PUISSANCE DU MICRO-ONDES	PUISSANCE DU GRIL
Combi. 1	C-1	55%	45%
Combi. 2	C-2	36%	64%

## 6. DÉCONGÉLATION PAR LE TEMPS

**a** Appuyez une fois sur  ' ensuite « dEF1 » apparaîtra.



**b** Tournez le bouton pour régler le temps de dégivrage souhaité, la valeur maximale du temps est « 95:00 ».

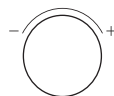

**c** Appuyez sur la touche  pour démarrer la décongélation.



### REMARQUE

- L'avertisseur sonore sonnera deux fois pour vous rappeler de retourner les aliments pendant la décongélation. S'il n'y a pas d'opération, le four continue de fonctionner.
- La puissance de décongélation est de P30, et ne peut être modifiée.

## 7. DÉCONGÉLATION PAR LE POIDS

**a** Appuyez sur  à plusieurs reprises pour choisir le type d'aliment, puis « dEF2 », « dEF3 » ou « dEF4 » s'affichera.



**b** Tournez le bouton pour régler le poids des aliments qui doit être compris entre « 100 g - 2000 g ».

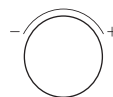

**c** Appuyez sur la touche  pour démarrer la décongélation.



AFFICHAGE LED	ALIMENT	POIDS
dEF2	Viande	100 g-2000 g
dEF3	Poulet	100 g-2000 g
dEF4	Poisson	100 g-2000 g





### REMARQUE

- L'avertisseur sonore sonnera deux fois pour vous rappeler de retourner les aliments pendant la décongélation. S'il n'y a pas d'opération, le four continue de fonctionner.

## 8. CUISSON RAPIDE

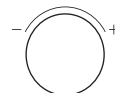
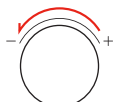
- a** Tournez le bouton vers la gauche pour régler un temps de cuisson avec une puissance de 100%.
- b** Continuez à tourner le bouton pour régler le temps de cuisson. La valeur maximale du temps est « 95:00 ».
- c** Appuyez sur la touche  pour démarrer la cuisson.





- a** Appuyez sur  pour cuire les aliments avec un niveau de puissance de 100% pendant 30 secondes. Chaque pression sur la même touche augmente le temps de 30 secondes dont le maximum est de « 95 :00 ».



## 9. CUISSON EN PLUSIEURS ÉTAPES

Exemple : pour décongeler pendant 5 minutes puis cuire aux micro-ondes à 80% pendant 7 minutes.

- a** Appuyez une fois sur , « DEF1 » apparaîtra.
- b** Tournez le bouton pour régler le temps de décongélation souhaité de 5 minutes.
- c** Appuyez sur  à plusieurs reprises jusqu'à ce que « P80 » s'affiche.
- d** Appuyez sur  pour confirmer le niveau de puissance.

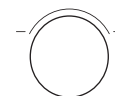

- e Tournez le bouton pour choisir le temps de cuisson de 7 minutes.

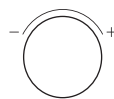

- f Appuyez sur la touche  pour démarrer la cuisson.



**REMARQUE** 

- La cuisson à deux étapes peut être réglée dans la cuisson à plusieurs étapes.
- Si vous réglez la fonction décongélation, elle fonctionnera automatiquement dans la première étape.
- La minuterie de cuisine, le menu automatique et la cuisson rapide ne peuvent pas être réglés comme cuisson à plusieurs étapes.

## 10. MENU AUTOMATIQUE

- a En mode veille, tournez le bouton vers la droite une fois, puis « A-1 » s'affichera.

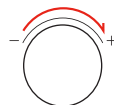

- b Tournez le bouton à plusieurs reprises pour choisir le menu dont vous avez besoin. Les 7 menus automatiques sont disponibles.



- c Appuyez sur  pour confirmer.



- d Tournez le bouton pour choisir le poids des aliments.

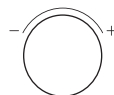

- e Appuyez sur la touche  pour démarrer la cuisson.



## GRAPHIQUE DU MENU AUTOMATIQUE

MENU	POIDS/QUANTITÉ	AFFICHAGE	NIVEAU DE PUISSANCE
A-1 Pop-corn	50 g 100 g	50 g 100 g	P100
A-2 Pommes de terre	1 (230 g) 2 (460 g) 3 (690 g)	1 2 3	P100
A-3 Pizza	200 g 400 g	200 g 400 g	P100
A-4 Légumes congelés	200 g 300 g 400 g	200 g 300 g 400 g	P100
A-5 Boisson	1 tasse (120 ml) 2 tasses (240 ml) 3 tasses (360 ml)	1 2 3	P100
A-6 Mon assiette (assiette de dîner)	250 g 350 g 500 g	250 g 350 g 500 g	P100
A-7 Viande (porc)	250 g 350 g 450 g	250 g 350 g 450 g	P80

## 11. FONCTION DE VERROUILLAGE POUR ENFANTS

---

Cette fonction peut être utilisée pour empêcher les enfants d'allumer accidentellement le four.

- a** Pour activer le verrouillage :

En mode veille, appuyez sur  STOP/CANCEL et maintenez-le enfoncé pendant trois secondes. Un signal sonore est émis et l'icône de verrouillage apparaîtra.



- b** Pour désactiver le verrouillage :

En mode verrouillage, appuyez sur  STOP/CANCEL et maintenez-le enfoncé pendant trois secondes. Un signal sonore retentit.



## 12. FONCTION D'INFORMATION

---

- a** Lorsque le four est en cours de cuisson, appuyez sur  Timer/Clock l'heure en cours s'affichera pendant trois secondes à l'écran.



- b** En mode de cuisson au micro-ondes, appuyez sur  Microwave pour vous renseigner sur le niveau de puissance. Il s'affichera pendant trois secondes.



- c** À l'état de gril et de cuisson combinée, appuyez sur  Function pour vous renseigner sur le mode de cuisson. Il s'affichera pendant trois secondes.



# NETTOYAGE ET ENTRETIEN

## NETTOYAGE

Avec un bon entretien et un bon nettoyage, votre appareil conserve son aspect et reste complètement fonctionnel pendant une longue durée. Nous allons vous expliquer ici comment entretenir et nettoyer correctement votre appareil.



### AVERTISSEMENT

- Le verre rayé de la porte de l'appareil peut se fissurer. N'utilisez pas de grattoir à vitre, de produits de nettoyage corrosifs ou abrasifs ou de détergents.
- La surface de l'appareil peut être endommagée si elle n'est pas nettoyée correctement. L'énergie micro-ondes peut s'échapper. Nettoyez régulièrement l'appareil et enlevez immédiatement tout reste d'aliments.
- Ne plongez pas l'appareil dans l'eau et ne le nettoyez pas avec un jet d'eau.

### Produits de nettoyage

Pour avoir les différentes surfaces non endommagées par l'utilisation d'un mauvais produit de nettoyage, respectez les informations du tableau suivant. Lavez soigneusement les nouveaux chiffons éponge avant utilisation.

#### Ne pas utiliser :



Produits de nettoyage agressifs ou abrasifs



Grattoirs en métal ou à vitre pour nettoyer les panneaux de porte



Grattoirs en métal ou en verre pour nettoyer le joint de la porte



Tampons et éponges à récurer durs



Produits de nettoyage à haute teneur en alcool

### FACE AVANT DE L'APPAREIL

#### Eau chaude savonneuse :

À nettoyer avec un torchon et à sécher avec un chiffon doux. N'utilisez pas de raclette pour vitre ou en métal.

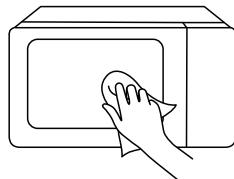



## FAÇADE DE L'APPAREIL EN ACIER INOXIDABLE

---

### Eau chaude savonneuse :

À nettoyer avec un torchon et à sécher avec un chiffon doux. Éliminez immédiatement toute éclaboussure et tache de calcaire, de graisse, d'amidon et d'albumine. De la corrosion peut se former sous ces taches et éclaboussures. Pour le nettoyage, n'utilisez pas de produits nettoyants pour vitres ou de raclette pour vitre ou en métal.

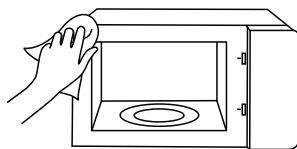

## COMPARTIMENT DE CUISSON EN INOX

---

### Eau chaude savonneuse ou solution vinaigrée :

À nettoyer avec un torchon et à sécher avec un chiffon doux. N'utilisez pas d'aérosol ou d'autres nettoyants agressifs ou abrasifs pour four. Les tampons à récurer, éponges rugueuses et nettoyants pour casseroles ne sont pas appropriés non plus. Ces produits laissent des rayures sur la surface. Laisser les surfaces intérieures sécher complètement.

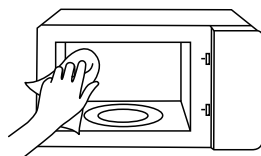

## CREUX DANS L'ESPACE DE CUISSON

---

### Chiffon humide :

L'eau ne doit pas s'écouler dans l'appareil par l'entraînement du plateau tournant. Séchez le plateau tournant avec un chiffon.

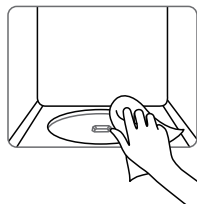

## PLATEAU TOURNANT ET ANNEAU ROTATIF

---

### Eau chaude savonneuse :

Lorsque vous remettez le plateau tournant sur l'anneau rotatif, il doit s'enclencher correctement.

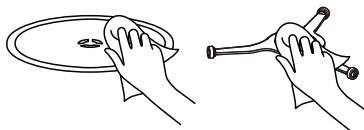

## PANNEAUX DE PORTE

---

### Nettoyants pour vitres :

À nettoyer avec un torchon. N'utilisez pas de grattoirs à vitre.

# DÉPANNAGE

Recherchez votre problème dans le tableau ci-dessous et essayez les solutions proposées pour le résoudre.

Si le four à micro-ondes ne fonctionne toujours pas correctement, contactez le centre de service agréé le plus proche.

PROBLÈME	CAUSE POSSIBLE	SOLUTION POSSIBLE
Le four ne démarre pas	<ul style="list-style-type: none"><li>a. Le cordon électrique du four n'est pas branché.</li><li>b. La porte est ouverte.</li><li>c. Mauvaise opération choisie.</li></ul>	<ul style="list-style-type: none"><li>a. Branchez l'appareil à une prise électrique.</li><li>b. Fermez la porte et réessayez.</li><li>c. Consultez le guide d'utilisation</li></ul>
Arc ou étincelle	<ul style="list-style-type: none"><li>a. Vous avez introduit des matériaux qu'il faut éviter d'utiliser dans un four à micro-ondes.</li><li>b. Le four est utilisé à vide.</li><li>c. La cavité contient de la nourriture renversée.</li></ul>	<ul style="list-style-type: none"><li>a. Utilisez uniquement des plats allant au four à micro-ondes.</li><li>b. N'utilisez pas le four à vide.</li><li>c. Nettoyez la cavité avec un chiffon doux et humide.</li></ul>
Aliments mal cuits	<ul style="list-style-type: none"><li>a. Vous avez introduit des matériaux qu'il faut éviter d'utiliser dans un four à micro-ondes.</li><li>b. Les aliments ne sont pas entièrement décongelés.</li><li>c. Temps de cuisson ou niveau de puissance inapproprié.</li><li>d. Les aliments ne sont ni retournés ni remués.</li></ul>	<ul style="list-style-type: none"><li>a. Utilisez uniquement des plats allant au four à micro-ondes.</li><li>b. Décongelez entièrement les aliments.</li><li>c. Utilisez un temps de cuisson ou un niveau de puissance approprié.</li><li>d. Retournez ou remuez les aliments.</li></ul>
Aliments trop cuits	Temps de cuisson ou niveau de puissance inapproprié.	Utilisez un temps de cuisson ou un niveau de puissance approprié.
Aliments insuffisamment cuits	<ul style="list-style-type: none"><li>a. Vous avez introduit des matériaux qu'il faut éviter d'utiliser dans un four à micro-ondes.</li><li>b. Les aliments ne sont pas entièrement décongelés.</li><li>c. Les orifices de ventilation du four sont obstrués.</li><li>d. Temps de cuisson ou niveau de puissance inapproprié.</li></ul>	<ul style="list-style-type: none"><li>a. Utilisez uniquement des plats allant au four à micro-ondes.</li><li>b. Décongelez entièrement les aliments.</li><li>c. Vérifiez que les orifices de ventilation du four ne sont pas obstrués.</li><li>d. Utilisez un temps de cuisson ou un niveau de puissance approprié</li></ul>
Décongélation incorrecte	<ul style="list-style-type: none"><li>a. Vous avez introduit des matériaux qu'il faut éviter d'utiliser dans un four à micro-ondes.</li><li>b. Temps de cuisson ou niveau de puissance inapproprié.</li><li>c. Les aliments ne sont ni retournés ni remués.</li></ul>	<ul style="list-style-type: none"><li>a. Utilisez uniquement des plats allant au four à micro-ondes.</li><li>b. Utilisez un temps de cuisson ou un niveau de puissance approprié.</li><li>c. Retournez ou remuez les aliments.</li></ul>



Conformément à la Directive sur les Déchets d'équipements électriques et électroniques (WEEE), les déchets doivent être triés, collectés et traités séparément. Si, dans le futur, vous devez vous débarrasser de ce produit, il NE faut PAS le jeter avec les ordures ménagères. Il faut apporter ce produit à un point de collecte WEEE disponible.



**FR**  
L'appareil, ses accessoires et son cordon d'alimentation sont recyclables

REPRISE  
À LA LIVRAISON

OU

À DÉPOSER  
EN MAGASIN

OU

À DÉPOSER  
EN DÉCHÈTERIE

A black bar containing a crossed-out trash bin icon on the left. The text 'FR' is in a small black box above the text 'L'appareil, ses accessoires et son cordon d'alimentation sont recyclables'. To the right are three options: 'REPRISE À LA LIVRAISON' with a person and cart icon, 'OU' with a shop icon, 'OU' with a recycling symbol icon, and 'À DÉPOSER EN DÉCHÈTERIE'.

Points de collecte sur [www.quefairedemesdechets.fr](http://www.quefairedemesdechets.fr)  
Privilégiez la réparation ou le don de votre appareil !

**#DetailsMatter**

MANUAL DE INSTRUCCIONES

# HORNO MICROONDAS

MW3-AG25PFI(MG)

Lea este manual de instrucciones antes de utilizar el aparato.

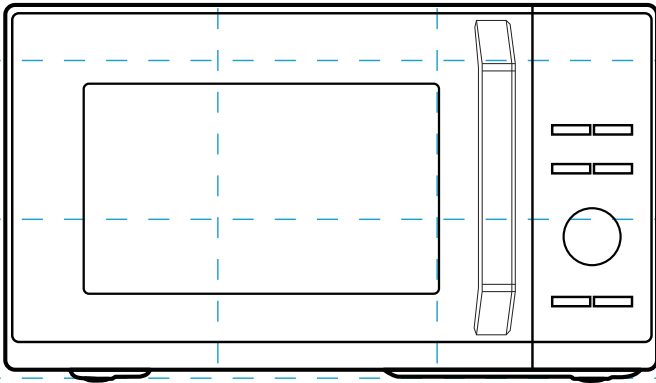

# CONTENIDO

## SEGURIDAD DEL PRODUCTO

Precauciones para evitar una posible exposición a una energía excesiva del microondas	ES-01
Especificaciones	ES-02
Instrucciones importantes de seguridad	ES-03
Para reducir el riesgo de lesiones a personas se requiere una instalación a tierra	ES-08
Limpieza	ES-10
Utensilios	ES-11
Materiales que puede usar en un horno microondas	ES-12
Materiales que no pueden usarse en un horno microondas	ES-14

## CONFIGURACIÓN DEL PRODUCTO

Preparación del horno	ES-15
-----------------------	-------

## INSTRUCCIONES DE USO

Antes de usarlo pro primera vez	ES-18
Funcionamiento	ES-19
Panel de control y características	ES-19
1. Configuración del reloj	ES-20
2. Configuración del temporizador de cocina	ES-21
3. Cocinar en el microondas	ES-21
4. Cocinar a la parrilla	ES-22
5. Cocción por combinación	ES-23
6. Descongelar por tiempo	ES-24
7. Descongelación por peso	ES-24
8. Cocina rápida	ES-25
9. Cocción multifase	ES-25

10. Menú automático .....	ES-26
11. Función de bloqueo para niños .....	ES-28
12. Función de pregunta .....	ES-28

## LIMPIEZA Y MANTENIMIENTO

Limpieza .....	ES-29
Solución de problemas .....	ES-31



### **NOTA**

ANTES DE PONER EN FUNCIONAMIENTO ESTE PRODUCTO, LEA, ENTIENDA Y SIGA ESTAS INSTRUCCIONES. ASEGÚRESE DE GUARDAR ESTE LIBRETO COMO REFERENCIA FUTURA.

## SEGURIDAD DEL PRODUCTO

### PRECAUCIONES PARA EVITAR UNA POSIBLE EXPOSICIÓN A UNA ENERGÍA EXCESIVA DEL MICROONDAS

---

(a). No intente operar este horno con la puerta abierta ya que esto puede provocar una exposición nociva a la energía del microondas. Es importante no romper o interferir en los cierres de seguridad.

(b). No coloque ningún objeto entre la cara delantera del horno y la puerta o permita que residuos de suelo o limpiador se acumulen en las superficies de sellado.

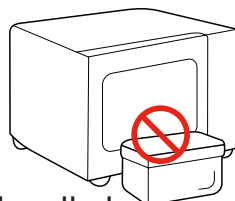

(c). **ADVERTENCIA:** Si la puerta o los sellos de la puerta presentan daños, no se debe operar el horno hasta que se haya reparado por parte de una persona competente.

#### APÉNDICE

---

Si el aparato no se mantiene en un buen estado de limpieza, su superficie puede degradarse y afectar la vida útil del aparato y provocar una situación peligrosa.



## ESPECIFICACIONES

---

MODELO	MW3-AG25PFI(MG)
VOLTAJE/FRECUENCIA NOMINAL	230-240 V~ 50 Hz
ENTRADA DE POTENCIA DE MICROONDAS	1400 W
POTENCIA DE SALIDA DE MICROONDAS	900 W
ENTRADA NOMINAL (PARRILLA)	1000-1100 W



### NOTA

Todas las imágenes de este manual tiene únicamente una finalidad ilustrativa; estas pueden ser ligeramente diferentes del equipo adquirido; remítase al producto real.

# INSTRUCCIONES IMPORTANTES DE SEGURIDAD



## ADVERTENCIA

Para reducir el riesgo de incendio, descarga eléctrica, lesiones a personas o exposición a una energía excesiva del horno microondas cuando use el aparato, siga precauciones básicas, incluyendo las siguientes:



Lea y siga estos puntos específicos:  
**«PRECAUCIONES PARA EVITAR UNA POSIBLE EXPOSICIÓN A UNA ENERGÍA EXCESIVA DEL MICROONDAS».**



Este aparato pueden usarlo niños a partir de 8 años y personas con capacidades físicas, sensoriales o mentales reducidas o con falta de experiencia o conocimientos, siempre y cuando se les haya supervisado o hayan recibido instrucciones sobre el uso del aparato de forma segura y entiendan los riesgos que conlleva. Los niños no deben jugar con el aparato. La limpieza y el mantenimiento del usuario no deben ser realizados por niños sin supervisión.



Mantenga el aparato y su cable alejado del alcance de los niños menores de 8 años.

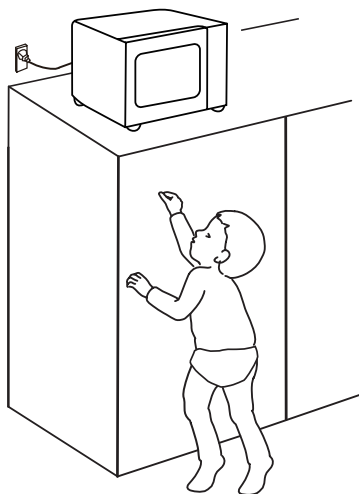

Si el cable de alimentación estuviera dañado, debe sustituirlo el fabricante, su agente de

# INSTRUCCIONES IMPORTANTES DE SEGURIDAD

servicio o una persona con cualificaciones similares para evitar riesgos.

---

 **ADVERTENCIA:** Asegúrese de que el aparato está apagado antes de sustituir la bombilla para evitar la posibilidad de una descarga eléctrica.

---

 **ADVERTENCIA:** Es peligroso para cualquiera excepto para una persona competente realizar ninguna operación de servicio o mantenimiento que implique la retirada de la carcasa que ofrece protección frente a la exposición de la energía del microondas.

---

 **ADVERTENCIA:** No se debe calentar líquidos u otros alimentos en recipientes cerrados, ya que pueden explotar.

 Cuando se calienten alimentos en recipientes de plástico o papel, vigílelos en el horno debido a la posibilidad de ignición.

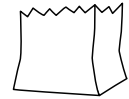

 Use únicamente utensilios que sean aptos para su uso en hornos microondas.

---

 Si se emite humo, apague o desenchufe el aparato y mantenga la puerta cerrada para contener cualquier llama.

---

 El calentamiento con el microondas de bebidas puede provocar un hervido eruptivo retardado y, por lo tanto, se debe tener cuidado cuando se maneje el recipiente.

---

 Los contenidos de biberones y jarras de alimentos infantiles deben agitarse o moverse y se debe comprobar la

# INSTRUCCIONES IMPORTANTES DE SEGURIDAD

temperatura antes de su consumo para evitar quemaduras.

 El horno debe limpiarse regularmente y eliminarse cualquier depósito de alimentos. Mantenga limpia la zona de la guía de ondas. Utilice un paño suave y húmedo para limpiarlo cuando haya restos de salpicaduras de alimentos en la zona de la guía de ondas o en la cavidad. Si no se limpian los restos de alimentos pueden producirse chispas inocuas o algo de humo en la cavidad del microondas, también puede producirse decoloración de la cavidad.

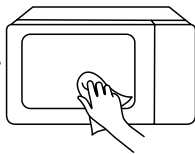

 En caso de no mantener el horno en condiciones de limpieza, se puede provocar un deterioro de la superficie que puede afectar de forma negativa

a la vida útil del aparato y probablemente provocar una situación peligrosa.

 Use únicamente la sonda de temperatura recomendada para este horno. (para hornos proporcionados con un servicio para usar una sonda sensible a la temperatura.)

 El horno microondas debe operarse con la puerta decorativa abierta. (Para hornos con una puerta decorativa.)

 Este aparato ha sido diseñado para uso doméstico y aplicaciones similares, como:

1. Zonas de cocina para el personal en tiendas, oficinas y otros entornos laborales;
2. Por parte de clientes en hoteles, moteles y otros entornos de tipo residencial;
3. Casas rurales;
4. Entornos de tipo pensión o albergue.

# INSTRUCCIONES IMPORTANTES DE SEGURIDAD

 El horno microondas está diseñado para el calentamiento de alimentos y bebidas. El secado de alimentos o ropa y el calentamiento de mantas eléctricas, zapatillas, esponjas, paños húmedos y similares puede provocar riesgo de lesiones, ignición o incendio.

 La superficie posterior del aparato debe colocarse contra una pared.

 La temperatura de las superficies accesibles puede ser alta cuando el aparato está en funcionamiento.

 **ADVERTENCIA:** Cuando el aparato está funcionando en el modo combinado, los niños solo deben usarlo bajo la supervisión de un adulto debido a las temperaturas generadas.

 El aparato está diseñado para usarse de forma independiente.

 Los huevos en su cáscara y los huevos cocidos no deben calentarse en hornos microondas ya que pueden explotar incluso después de que haya finalizado el calentamiento en el microondas.

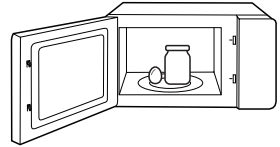



 El horno microondas no debe colocarse en un armario salvo que se haya probado dentro del mismo.

 No se permiten recipientes metálicos para alimentos y bebidas durante la cocción con el microondas.

 El aparato no debe limpiarse con un limpiador a vapor.

# INSTRUCCIONES IMPORTANTES DE SEGURIDAD

 Los aparatos no están diseñados para operarse por medio de un temporizador externo o un sistema de mando a distancia separado.

 El aparato no se debe instalar tras puertas decorativas para evitar sobrecalentamientos. (Esto no es aplicable a aparatos con una puerta decorativa.)

LÉALO DETENIDAMENTE Y GUÁRDELO  
COMO REFERENCIA FUTURA

# PARA REDUCIR EL RIESGO DE LESIONES A PERSONAS SE REQUIERE UNA INSTALACIÓN A TIERRA

Este aparato debe conectarse a tierra. En caso de que se produzca un cortocircuito eléctrico, la toma a tierra reduce el riesgo de descarga eléctrica ofreciendo un cable de escape para la corriente eléctrica.

Este aparato está equipado con un cable que tiene un cable a tierra con un enchufe a tierra. El enchufe debe conectarse a una toma que esté debidamente instalada y conectada a tierra.

**ADVERTENCIA** - Un uso inadecuado de la toma a tierra puede provocar un riesgo de descarga eléctrica. Consulte con un electricista cualificado o un reparado si no comprende totalmente las instrucciones a tierra o si tiene dudas de si el aparato está debidamente conectado a tierra.

Si es necesario utilizar un cable eléctrico de extensión, utilice únicamente un cable de 3 hilos.



**PELIGRO**

Riesgo de descarga eléctrica:

Tocar alguno de los componentes internos puede provocar graves lesiones personales o la muerte.

No desmonte este aparato.

# PARA REDUCIR EL RIESGO DE LESIONES A PERSONAS SE REQUIERE UNA INSTALACIÓN A TIERRA



## ADVERTENCIA

Riesgo de descarga eléctrica:

Un uso inadecuado de la toma a tierra puede provocar una descarga eléctrica. No lo enchufe en una toma hasta que el aparato esté debidamente instalado y conectado a tierra.

1. Se proporciona un cable de alimentación corto para reducir los riesgos que se derivan de que se enrede o que se tropiecen con él como con un cable largo.
2. Si se usa un cable de extensión o un cable largo:
  - (1). La clasificación eléctrica que aparece marcada en el juego de cables o el cable de extensión debe ser como mínimo igual que la clasificación eléctrica del aparato.
  - (2). El cable de extensión debe ser de tipo a tierra de 3 cables.
  - (3). El cable más largo debe colocarse de modo que no cuelgue sobre el mostrador o la mesa donde los niños puedan tirar de él o tropezarse sin querer.



# LIMPIEZA

Asegúrese de desenchufar el aparato de la alimentación.

1. Limpie la cavidad del horno tras usarlo con un paño ligeramente húmedo.
2. Limpie los accesorios de la forma habitual con agua jabonosa.
3. El marco de la puerta y el sello y las piezas cercanas deben limpiarse con cuidado con un paño húmedo cuando estén sucias.
4. No use limpiadores abrasivos duros o ralladores metálicos afilados para limpiar el cristal de la puerta del microondas, ya que pueden arañar la superficie, lo que puede provocar que se destruya el cristal.
5. Consejo de limpieza --- Para una limpieza más sencilla de las paredes de la cavidad que los alimentos cocinados pueden tocar: Coloque la mitad de un limón en un bol, añada 300 ml de agua y caliéntelo al 100 % de la potencia del microondas durante 10 minutos. Limpie el horno usando un paño suave y seco.

# UTENSILIOS



## PRECAUCIÓN

Riesgo de lesiones personales:

Es peligroso para cualquiera excepto para una persona competente realizar ninguna operación de servicio o mantenimiento que implique la retirada de la carcasa que ofrece protección frente a la exposición de la energía del microondas. Consulte las instrucciones en «**Materiales que pueden usarse en un horno microondas**» o «**Materiales que no pueden usarse en un horno microondas**».

Puede ser que ciertos utensilios no metálicos no sean seguros para usar en el microondas. Si tiene cualquier duda, puede probar el utensilio en cuestión siguiendo el procedimiento que aparece debajo.

## Prueba de utensilios:

1. Llene un recipiente para microondas con 1 tapa de agua fría (250 ml) conjuntamente con el utensilio en cuestión.
2. Cocine a máxima potencia durante 1 minuto.
3. Toque con cuidado el utensilio. Si el utensilio vacío está caliente, no lo use para cocinar en el microondas.
4. No supere el tiempo de cocción de 1 minuto.

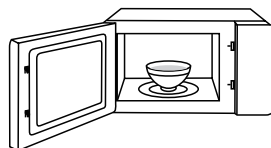





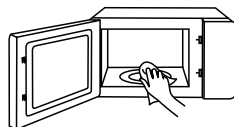











## NOTA

MANTENER LIMPIAS LA CAVIDAD Y LA ZONA DE LA GUÍA DE ONDAS

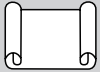

# MATERIALES QUE PUEDE USAR EN UN HORNO MICROONDAS

UTENSILIOS	COMENTARIOS
 Plato para dorar	Siga las instrucciones del fabricante. El fondo del plato para dorar debe de estar al menos 5 mm (3/16 pulgadas) por encima del plato giratorio. Un uso incorrecto puede provocar que se rompa el plato giratorio. 
 Platos y cubiertos	Solo para microondas. Siga las instrucciones del fabricante. No use platos rajados o astillados. 
 Jarras de cristal	Retire siempre la tapa. Úselo únicamente para calentar alimentos hasta que estén calientes. La mayoría de las jarras de cristal no son resistentes al calor y pueden romperse. 
 Cristalería	Utilice únicamente vidrio resistente al calor del horno. Asegúrese de que no tiene un borde metálico. No use platos rajados o astillados. 
 Bolsas para cocina en horno	Siga las instrucciones del fabricante. No lo cierre con un lazo metálico. Realice rajaduras para permitir que escape el vapor. 
 Platos y tazas de papel	Úselo únicamente para cocinar/calentar a corto plazo. No lo deje sin atender mientras cocina. 
 Toallitas de papel	Use una cubierta alimentaria para recalentar y absorber la grasa. Úselo con supervisión para la cocina a corto plazo solo. 
 Papel de pergamino	Úselo como una tapa para evitar salpicaduras o como un envoltorio para el vapor. 

# MATERIALES QUE PUEDE USAR EN UN HORNO MICROONDAS

## UTENSILIOS

## COMENTARIOS



Plástico

Solo para microondas. Siga las instrucciones del fabricante. Deben estar etiquetados como «Seguros para microondas». Algunos recipientes de plástico se ablandan, a medida de que los alimentos en su interior se calientan. Las «bolsas de cocción» y las bolsas de plástico debe tener ranuras, estar agujereadas o con ventilación tal y como diga el envase.



Envoltorio de plástico

Solo para microondas. Úselo para cubrir los alimentos durante la cocción para retener la humedad. No deje que el envoltorio plástico toque los alimentos.

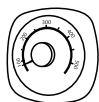

Termómetros

Únicamente seguros para el microondas (termómetros de carne y dulces).



Papel de cera

Úselo como una tapa para evitar salpicaduras y retener la humedad.



# MATERIALES QUE NO PUEDEN USARSE EN UN HORNO MICROONDAS

## UTENSILIOS

## COMENTARIOS



Bandeja de aluminio

Puede provocar que se arquee. Transfiera alimentos a un plato apto para microondas.



Cartón alimentario con asa de madera

Puede provocar que se arquee. Transfiera alimentos a un plato apto para microondas.



Utensilios de metal o con adornos de metal

El metal protege los alimentos de la energía del microondas. El reborde metálico puede causar que se arquee.



Ataduras de alambre

Pueden provocar que se arqueen y causar un incendio en el horno.

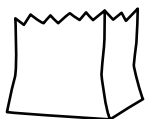

Bolsas de papel

Pueden causar un incendio en el horno.



Espuma de plástico

La espuma de plástico puede fundirse o contaminar el líquido en el interior cuando se expone a altas temperaturas.



Madera

La madera se secará cuando se use en el microondas y se puede dividir o agrietar.



# CONFIGURACIÓN DEL PRODUCTO

## PREPARACIÓN DEL HORNO

### NOMBRE DE LOS COMPONENTES Y ACCESORIOS DEL HORNO MICROONDAS

Retire el horno y todos los materiales del cartón y de la cavidad del horno.

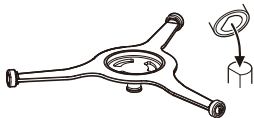

Conjunto de Anillo de Plato Giratorio

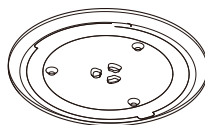

Bandeja de cristal

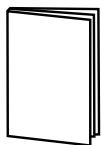

Manual de instrucciones

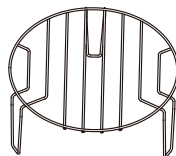

Rejilla del grill (no puede usarse en la función microondas y debe colocarse en la bandeja de cristal)

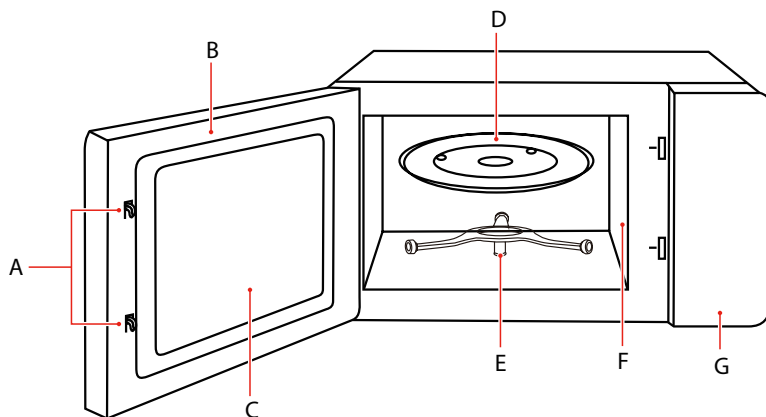

- A) Sistema de bloqueo de seguridad
- B) Montaje de la puerta
- C) Ventana de observación
- D) Bandeja de cristal

- E) Conjunto de anillo de plato giratorio
- F) Cubierta de la guía de ondas
- G) Panel de control



En caso de existir diferencias entre el aparato y las imágenes de este manual, prevalecerá el producto.

# PREPARACIÓN DEL HORNO

## INSTALACIÓN DEL PLATO GIRATORIO

Limpie el compartimento de cocción y coloque el plato giratorio.

Para las instalaciones nuevas, asegúrese de que todo el embalaje y la cinta hayan sido extraídos del eje del plato giratorio.

Antes de usar el aparato para cocinar alimentos por primera vez, deberá colocar correctamente el plato giratorio en posición. Debe limpiar el compartimento de cocción y los accesorios.

También puede consultar la sección de limpieza.

Cómo colocar el plato giratorio en posición:

1. Coloque el conjunto del aro del plato giratorio ② en el recoveco del compartimento de cocción.
2. Coloque la bandeja de cristal ① en el conjunto del aro del plato giratorio ②.

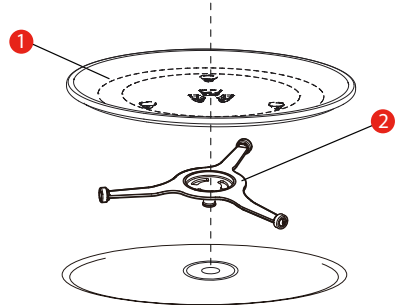

- 1) Bandeja de cristal  
2) Anillo giratorio

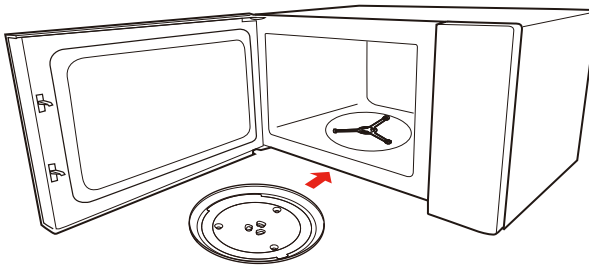

**NOTA**

- Nunca use el aparato sin el plato giratorio. Asegúrese de que se encuentra instalado correctamente. El plato giratorio puede girar en sentido horario y antihorario.
- Nunca coloque la bandeja de cristal boca abajo. La bandeja de cristal nunca debe confinarse.
- Tanto la bandeja de cristal como el anillo del plato giratorio deben usarse siempre al cocinar.
- Todos los alimentos y recipientes de alimentos se colocan siempre en la bandeja de cristal para cocinarlos.
- Nunca limite el movimiento del plato giratorio.
- Si la bandeja de cristal o el anillo del plato giratorio se agrietan o rompen, póngase en contacto con su centro de servicio autorizado más cercano.

## INSTALACIÓN EN LA ENCIMERA

Retire todos los materiales del envase y accesorios. Examine el horno en busca de cualquier daño como melladuras o la puerta rota. No instale el horno si está dañado.

Carcasa: Retire cualquier película protectora que se encuentre en la superficie de la carcasa del horno microondas. No retire la cubierta que está fijada a la cavidad del horno para proteger el magnetrón.

## INSTALACIÓN

1. Seleccione una superficie plana que ofrezca suficiente espacio abierto para las ventilaciones de admisión y/o salida.
  - a. La altura mínima de instalación es de 85cm.
  - b. La parte trasera del aparato debe colocarse contra la pared. Deje un espacio libre mínimo de 30 cm por encima del horno. Es necesario un espacio mínimo de 20cm entre el horno y cualquier pared adyacente.
  - c. No retire las patas de la parte inferior del horno.
  - d. Bloquear las aperturas de entrada y/o salida puede dañar el horno.
  - e. Coloque el horno tan alejado como sea posible de radio y TV. El funcionamiento del horno microondas puede causar interferencias con la recepción de su radio o TV.

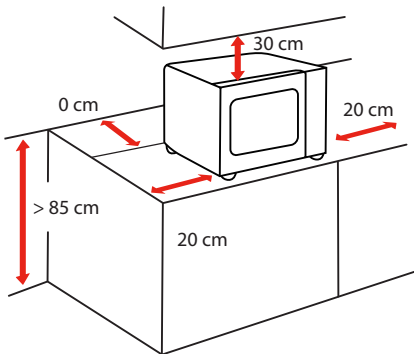

LATERAL	DISTANCIA CM
Parte superior	30 cm
Izquierdo	20 cm
Derecha	20 cm
Detrás	0 cm
Delantero	Abierto

2. Enchufe el horno microondas a una toma doméstica estándar. Asegúrese de que la tensión y la frecuencia son las mismas que la tensión y la frecuencia de la etiqueta de calificación.



**NOTA**

- No instale el horno sobre una cocina u otros aparatos que produzcan calor. Si se instala cerca o sobre una fuente de calor, se puede dañar el horno y quedará anulada la garantía.

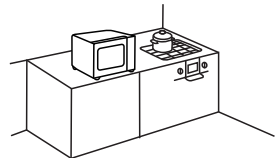

La superficie accesible puede estar caliente durante su funcionamiento



# INSTRUCCIONES DE USO

## ANTES DE USARLO POR PRIMERA VEZ

**Es normal que el horno produzca malos olores desagradable cuando se use por primera vez.**

Esta sección le dice lo que necesita hacer antes de usar el microondas para preparar alimentos por primera vez. Lea antes la sección titulada «**SEGURIDAD DEL PRODUCTO**».

Antes de que pueda usar el nuevo aparato, será necesario que coloque correctamente en su lugar el plato giratorio. Asimismo, debe limpiar el compartimento de cocción y sus accesorios.



**NOTA**

- Nunca use el aparato sin el plato giratorio.
- Asegúrese de que se encuentra instalado correctamente. El plato giratorio puede girar en sentido horario y antihorario.

# FUNCIONAMIENTO

## PANEL DE CONTROL Y CARACTERÍSTICAS

---

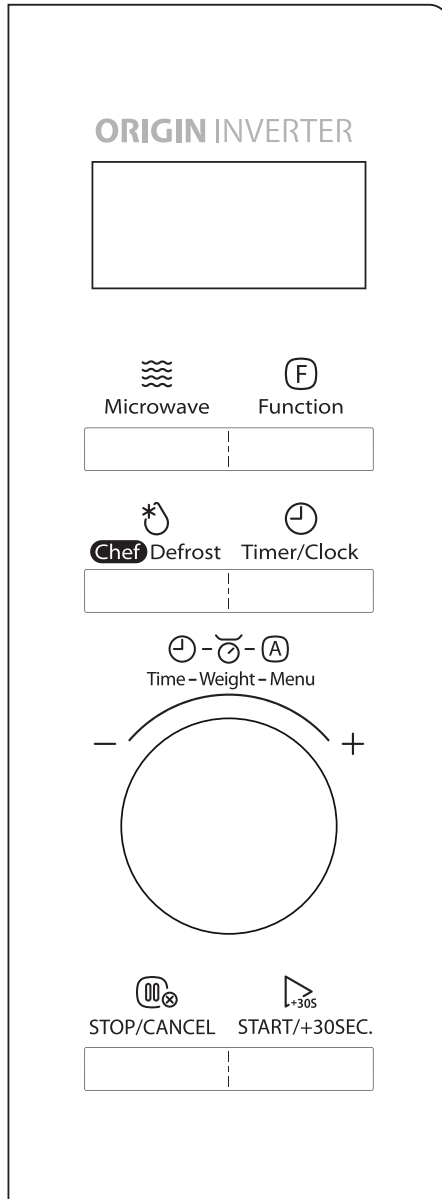



## 1. CONFIGURACIÓN DEL RELOJ

**a** Pulse  Timer/Clock dos veces y aparecerá «00:00».

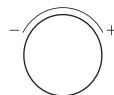

**b** Gire el botón regulador para establecer la hora.



**c** Pulse  Timer/Clock o  START/+30SEC. para confirmar las cifras de las horas.





o

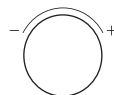

**d** Gire el botón regulador para establecer los minutos.



**e** Pulse  Timer/Clock o  START/+30SEC. para confirmarlo. El reloj quedará configurado.



o



**NOTA**

- El reloj es de 24 horas. Si el reloj no está configurado, no funcionará cuando se encienda.
- Para reiniciar el reloj, repita los pasos del a al e.

## 2. CONFIGURACIÓN DEL TEMPORIZADOR DE COCINA

a Pulse  una vez y aparecerá «00:00».



b Gire el botón regulador para establecer el tiempo deseado. El valor máximo de tiempo es "95:00".

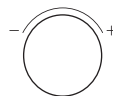

c Pulse  para confirmarlo. El temporizador empezará una cuenta atrás.







**NOTA**



- El temporizador de la cocina es un temporizador.
- No es posible configurar ningún otro programa mientras esté activado el temporizador de cocina.

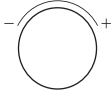

## 3. COCINAR EN EL MICROONDAS

Dispone de diez niveles de potencia.

NIVEL	POTENCIA	PANTALLA
1	100 %	P100
2	90 %	P90
3	80 %	P80
4	70 %	P70
5	60 %	P60
6	50 %	P50
7	40 %	P40
8	30 %	P30
9	20 %	P20
10	10 %	P10

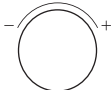



- a** Pulse  Microwave más tiempo para elegir el nivel de potencia. 
- a** **O** Pulse  Microwave una vez y después gire el mando giratorio para establecer el nivel de potencia.  
- Hay 10 niveles de potencia disponibles.

- b** Pulse  START/+30SEC. para confirmar el nivel de potencia. 
- c** Gire el mando giratorio para ajustar el tiempo de cocción; el valor máximo de tiempo es de «95:00». 

- d** Pulse  START/+30SEC. para empezar a cocinar. 

## 4. COCINAR A LA PARRILLA

---

- a** Pulse  Function una vez y aparecerá «G-1». 
- b** Pulse  START/+30SEC. para confirmar el modo. 
- c** Gire el mando giratorio para ajustar el tiempo de cocción; el valor máximo de tiempo es de «95:00». 

d Pulse  para empezar a cocinar.



**NOTA**

- Sonará el pitido para recordarle que dé la vuelta a los alimentos durante la cocción.  
Si no hay ninguna operación, el horno continuará funcionando.

## 5. COCCIÓN POR COMBINACIÓN

a Pulse  más tiempo para elegir el modo de cocción que desee. «C-1, C-2» están disponibles.



Pulse  una vez y después gire el mando giratorio para elegir el modo de cocción.



b Pulse  para confirmar el modo.



c Gire el mando giratorio para ajustar el tiempo de cocción; el valor máximo de tiempo es de «95:00».

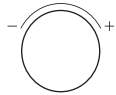

d Pulse  para empezar a cocinar.



### CUADRO DE COCCIÓN POR COMBINACIÓN

FUNCIÓN	PANTALLA	POTENCIA DEL MICROONDAS	POTENCIA DE LA PARRILLA
Combi. 1	C-1	55 %	45 %
Combi. 2	C-2	36 %	64 %

## 6. DESCONGELAR POR TIEMPO

**a** Pulse  una vez y luego aparecerá «dEF1».



**b** Gire el mando giratorio para ajustar el tiempo de descongelación deseado; el valor máximo de tiempo es de «95:00».

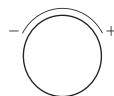

**c** Pulse  para empezar a descongelar.



**NOTA**

- Sonará el pitido para recordarle que dé la vuelta a los alimentos durante la descongelación. Si no hay ninguna operación, el horno continuará funcionando.
- La potencia de descongelación es de P30 y no puede modificarse.

## 7. DESCONGELACIÓN POR PESO

**a** Pulse  más tiempo para elegir el tipo de comida y, a continuación, aparecerá «dEF2», «dEF3» o «dEF4».



**b** Gire el mando giratorio para establecer el peso de los alimentos; debe estar entre «100 g-2000 g».

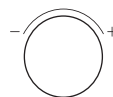

**c** Pulse  para empezar a descongelar.



PANTALLA LED	ALIMENTO	PESO
dEF2	Carne	100 g-2000 g
dEF3	Pollo	100 g-2000 g
dEF4	Pescado	100 g-2000 g





**NOTA**

- Sonará el pitido para recordarle que dé la vuelta a los alimentos durante la descongelación. Si no hay ninguna operación, el horno continuará funcionando.

## 8. COCINA RÁPIDA

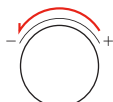
- a** Gire el mando giratorio a la izquierda para establecer el tiempo de cocción al 100 % de potencia.
- b** Continúe girando el mando giratorio para ajustar el tiempo de cocción; el valor máximo de tiempo es de «95:00».
- c** Pulse  para empezar a cocinar.



- a** Pulse  para cocinar los alimentos al 100 % de potencia durante 30 segundos. Cada vez que pulse el mismo botón, añadirá 30 segundos y el valor máximo es «95:00».



## 9. COCCIÓN MULTIFASE

Ejemplo: Descongele la comida durante 5 minutos y luego cocínela al 80 % de potencia del microondas durante 7 minutos.

- a** Pulse  una vez y aparecerá «dEF1».



- b** Gire el mando giratorio para establecer el tiempo de descongelación deseado a 5 minutos.



- c** Pulse  más tiempo hasta que aparezca «P80».





- d** Pulse  para confirmar el nivel de potencia.



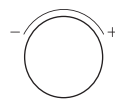

- e Gire el mando giratorio para establecer el tiempo de cocción a 7 minutos.



- f Pulse  para empezar a cocinar.

 START/+30SEC.



**NOTA**

- Con el cocinado multifase se pueden establecer dos fases de cocinado.
- Si establece la función de descongelación, se iniciará automáticamente en la primera fase.
- No se pueden configurar el temporizador de cocina, el menú automático ni la cocción rápida como una de las multifases.

## 10. MENÚ AUTOMÁTICO

- a En modo de espera, gire el mando giratorio a la derecha una vez hasta que aparezca «A-1».

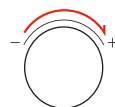

- b Gire el mando giratorio repetidamente para elegir la opción del menú que necesite. Los 7 menús automáticos están disponibles.

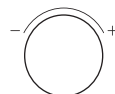

- c Pulse  para confirmarlo.

 START/+30SEC.

- d Gire el mando giratorio para fijar el peso de los alimentos.

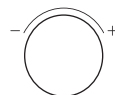

- e Pulse  para empezar a cocinar.

 START/+30SEC.

## CUADRO DE MENÚ AUTOMÁTICO

MENÚ	PESO/CANTIDAD	PANTALLA	NIVEL DE ALIMENTACIÓN
A-1 Palomitas	50 g 100 g	50 g 100 g	P100
A-2 Patata	1 (230 g) 2 (460 g) 3 (690 g)	1 2 3	P100
A-3 Pizza	200 g 400 g	200 g 400 g	P100
A-4 Vegetales congelados	200 g 300 g 400 g	200 g 300 g 400 g	P100
A-5 Bebidas	1 taza (120 ml) 2 tazas (240 ml) 3 tazas (360 ml)	1 2 3	P100
A-6 Mi plato (Plato de la cena)	250 g 350 g 500 g	250 g 350 g 500 g	P100
A-7 Carne (cerdo)	250 g 350 g 450 g	250 g 350 g 450 g	P80

## 11. FUNCIÓN DE BLOQUEO PARA NIÑOS

---

Puede usar esta función para evitar que los niños enciendan el horno por accidente.

- a** Para activar el bloqueo:

En modo de espera, mantenga pulsado  STOP/CANCEL durante tres segundos. Escuchará un pitido y se mostrará el icono de un candado.



- b** Para desactivar el bloqueo:

En estado de bloqueo, mantenga pulsado  STOP/CANCEL durante tres segundos. Suenan tres pitidos.



## 12. FUNCIÓN DE PREGUNTA

---

- a** Cuando el horno esté cocinando, pulse  Timer/Clock y aparecerá el tiempo actual durante tres segundos en la pantalla.



- b** En el estado de cocción en el microondas, pulse  Microwave para ver información sobre el nivel de potencia. Se mostrará durante tres segundos.



- c** En el estado de asado y cocción por combinación, pulse  Function para ver información sobre el modo de cocción. Se mostrará durante tres segundos.



# LIMPIEZA Y MANTENIMIENTO

## LIMPIEZA

Con un buen cuidado y limpieza, el aparato mantendrá su apariencia y seguirá funcionando perfectamente durante un periodo prolongado de tiempo. Aquí explicaremos cómo debe cuidar correctamente y limpiar el aparato.



### ADVERTENCIA

- Un vidrio rallado en la puerta del aparato puede desarrollarse en una grieta.  
No use un rascador de vidrio, productos de limpieza afilados o abrasivos o detergentes.
- La superficie del aparato puede dañarse si no se limpia adecuadamente. Se puede escapar la energía del microondas.  
Limpie el aparato de forma regular y retire inmediatamente cualquier resto de alimentos.
- No sumerja el aparato en agua o lo limpie bajo un chorro de agua.

## Agente de limpieza

Para asegurar que no se dañan las diferentes superficies usando el agente de limpieza erróneo, observe la información de la tabla. Lave las nuevas bayetas bien antes de usarlas.

### No use:



Agentes de limpieza abrasivos o ásperos



Rasquetas metálicas o de vidrio para limpiar los paneles de la puerta



Rasquetas metálicas o de vidrio para limpiar el sello de la puerta



Estropajos o esponjas duras



Agente de limpieza con alto contenido en alcohol

## PARTE DELANTERA DEL APARATO

### Agua caliente jabonosa:

Límpielo usando un paño de platos y después séquelos con un paño suave.

No use rasquetas metálicas o de vidrio para la limpieza.

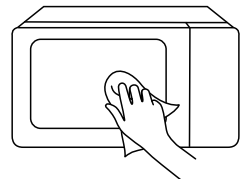

## PARTE DELANTERA DEL ELECTRODOMÉSTICO CON ACERO INOXIDABLE

---

### Agua caliente jabonosa:

Límpielo usando un paño de platos y después séquelos con un paño suave.  
Retire las salpicaduras y zonas de cal, grasa, almidón y albúmina inmediatamente. Se puede formar corrosión bajo estas zonas o salpicaduras. No use limpiadores de vidrio o metal ni rasquetas de vidrio para la limpieza.

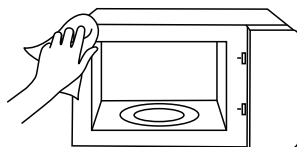

## COMPARTIMENTO DE COCCIÓN FABRICADO EN ACERO INOXIDABLE

---

### Agua jabonosa caliente o solución de vinagre:

Límpielo usando un paño de platos y después séquelos con un paño suave. No use spray para horno o ningún otro limpiador agresivo ni materiales abrasivos. Tampoco son aptos estropajos, bayetas, salvauñas y limpiadores de cazuelas. Estos elementos rallan la superficie. Deje que las superficies interiores se sequen completamente.

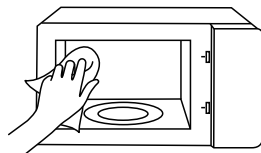

## RECOVECO EN EL COMPARTIMENTO DE COCCIÓN

---

### Paño húmedo:

No se debe permitir que el agua corra por el aparato a través de la propulsión del plato giratorio. Limpie la propulsión del plato giratorio con un paño.

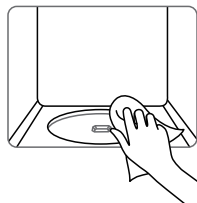

## PLATO GIRATORIO Y ANILLO DEL RODILLO

---

### Agua caliente jabonosa:

Cuando vuelva a colocar el plato giratorio en su recoveco, debe colocarse correctamente.

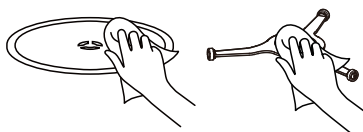

## PANEL DE LA PUERTA

---

### Limpiador de vidrio:

Límpielo con una bayeta. No use rasquetas de vidrio.

# SOLUCIÓN DE PROBLEMAS

Verifique el problema utilizando la siguiente tabla y pruebe las soluciones para cada problema. Si el horno microondas aún no funciona correctamente, póngase en contacto con el centro de servicio autorizado más cercano.

PROBLEMA	POSIBLE CAUSA	POSIBLE SOLUCIÓN
El horno no enciende	<ul style="list-style-type: none"> <li>a. El cable eléctrico del horno no está enchufado.</li> <li>b. La puerta está abierta.</li> <li>c. Se estableció una operación incorrecta.</li> </ul>	<ul style="list-style-type: none"> <li>a. Conecte el horno al tomacorriente.</li> <li>b. Cierre la puerta e inténtelo de nuevo.</li> <li>c. Compruebe las instrucciones</li> </ul>
Arcos eléctricos y chispas	<ul style="list-style-type: none"> <li>a. Se utilizaron materiales no aptos para horno microondas.</li> <li>b. El horno funciona cuando está vacío.</li> <li>c. Quedan restos de comida en el interior del horno.</li> </ul>	<ul style="list-style-type: none"> <li>a. Utilice únicamente utensilios de cocina aptos para microondas.</li> <li>b. No utilice el horno microondas vacío.</li> <li>c. Limpie la cavidad con un paño suave húmedo.</li> </ul>
Alimentos cocidos de forma desigual	<ul style="list-style-type: none"> <li>a. Se utilizaron materiales no aptos para horno microondas.</li> <li>b. La comida no se descongela completamente.</li> <li>c. El tiempo de cocción y el nivel de potencia no son adecuados.</li> <li>d. La comida no se da vuelta ni se revuelve.</li> </ul>	<ul style="list-style-type: none"> <li>a. Utilice únicamente utensilios de cocina aptos para microondas.</li> <li>b. Descongele completamente los alimentos.</li> <li>c. Utilice el tiempo de cocción y el nivel de potencia adecuados.</li> <li>d. Voltee o revuelva los alimentos.</li> </ul>
Alimentos sobrecocidos	El tiempo de cocción y el nivel de potencia no son adecuados.	Utilice el tiempo de cocción y el nivel de potencia adecuados.
Alimentos mal cocidos	<ul style="list-style-type: none"> <li>a. Se utilizaron materiales no aptos para horno microondas.</li> <li>b. La comida no se descongela completamente.</li> <li>c. Los puertos de ventilación del horno están obstruidos.</li> <li>d. El tiempo de cocción y el nivel de potencia no son adecuados.</li> </ul>	<ul style="list-style-type: none"> <li>a. Utilice únicamente utensilios de cocina aptos para microondas.</li> <li>b. Descongele completamente los alimentos.</li> <li>c. Verifique que los puertos de ventilación del horno no estén obstruidos.</li> <li>d. Utilice el tiempo de cocción y el nivel de potencia adecuados</li> </ul>
Descongelación incorrecta	<ul style="list-style-type: none"> <li>a. Se utilizaron materiales no aptos para horno microondas.</li> <li>b. El tiempo de cocción y el nivel de potencia no son adecuados.</li> <li>c. La comida no se da vuelta ni se revuelve.</li> </ul>	<ul style="list-style-type: none"> <li>a. Utilice únicamente utensilios de cocina aptos para microondas.</li> <li>b. Utilice el tiempo de cocción y el nivel de potencia adecuados.</li> <li>c. Voltee o revuelva los alimentos.</li> </ul>



Según la directiva sobre Eliminación de Equipos Eléctricos y Electrónicos (WEEE), WEEE deben recogerse y tratarse de forma separada. Si en cualquier momento en el futuro necesita deshacerse de este producto NO se deshaga de este producto como un residuo doméstico. Envíe este producto a puntos de recogida WEEE siempre que estén disponibles.



**#DetailsMatter**



# BRUGERVEJLEDNING

## MIKROBØLGEOVN

MW3-AG25PFI(MG)

Læs vejledningen, før du bruger apparatet.

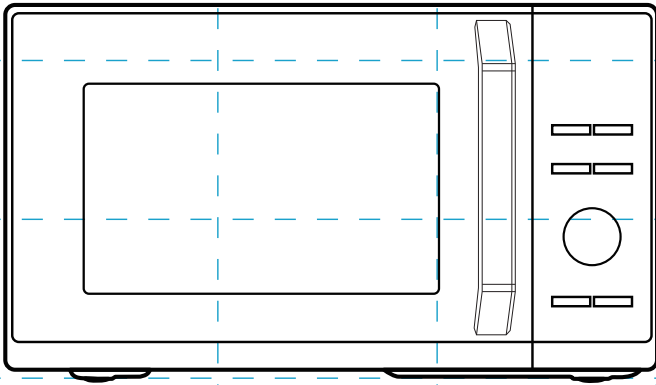

# INDHOLD

## PRODUKTSIKKERHED

Forholdsregler for at undgå mulig eksponering for kraftig mikrobølgeenergi .....	DA-01
Specifikationer .....	DA-02
Vigtige sikkerhedsanvisninger .....	DA-03
Installation med jordforbindelse for at undgå risiko for personskade .....	DA-08
Rengøring .....	DA-10
Køkkenredskaber .....	DA-11
Materialer som kan bruges i mikrobølgeovn .....	DA-12
Materialer, der ikke kan bruges i mikrobølgeovn .....	DA-14

## INDSTILLING AF PRODUKT

Opsætning af din ovn .....	DA-15
----------------------------	-------

## VEJLEDNING

Før første ibrugtagning .....	DA-18
Betjening .....	DA-19
Kontrolpanel og funktioner .....	DA-19
1. Indstilling af uret .....	DA-20
2. Indstilling af køkkentimeren .....	DA-21
3. Tilberedning med mikrobølger .....	DA-21
4. Tilberedning med grill .....	DA-22
5. Tilberedning med kombinationsprogram .....	DA-23
6. Optøning efter tid .....	DA-24
7. Optøning efter vægt .....	DA-24
8. Hurtig tilberedning .....	DA-25
9. Tilberedning i flere trin .....	DA-25

10. Automatisk menu .....	DA-26
11. Børnelås .....	DA-28
12. Oplysningsfunktion .....	DA-28

## RENGØRING OG VEDLIGEHOLDELSE

Rengøring .....	DA-29
Fejlfinding .....	DA-31



### **BEMÆRK**

FØR DU BRUGER APPARATET, SKAL DU LÆSE,  
FORSTÅ OG FØLGE VEJLEDNINGEN.  
SØRG FOR AT GEMME VEJLEDNINGEN TIL SENERE  
BRUG.

# PRODUKTSIKKERHED

## FORHOLDSREGLER FOR AT UNDGÅ MULIG EKSPONERING FOR KRAFTIG MIKROBØLGEENERGI

---

- (a). Brug ikke ovnen med åben dør, da det kan medføre skadelig eksponering for mikrobølgeenergi. Det er vigtigt ikke at bryde eller ændre sikkerhedslåsene.
- (b). Placér ikke genstande mellem ovnens forside og døren, og lad ikke snavs eller rester af rengøringsmiddel samle sig på overfladen af forseglingen.
- (c). **ADVARSEL:** Hvis døren eller dørtætningerne er beskadigede, må ovnen ikke bruges, før den er repareret af en kvalificeret person.

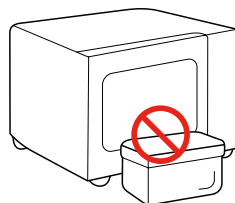

### TILLÆG

---

Hvis apparatet ikke rengøres grundigt, kan dets overflade ødelægges og påvirke apparatets levetid samt skabe en farlig situation.

## SPECIFIKATIONER

---

MODEL	MW3-AG25PFI(MG)
SPÆNDING/FREKVENNS	230-240 V~ 50 Hz
MIKROBØLGEINDGANGSEFFEKT	1.400 W
MIKROBØLGEUDGANGSEFFEKT	900 W
NOMINELT INPUT (GRILL)	1.000-1.100 W



### BEMÆRK

Alle billeder i vejledningen er kun til illustrative formål. Billederne kan variere lidt fra det købte udstyr. Se det faktiske produkt.

# VIGTIGE SIKKERHEDSANVISNINGER



## ADVARSEL

For at reducere risikoen for brand, elektrisk stød, personskade eller eksponering for kraftig mikrobølgeenergi ved brug af apparatet skal du overholde de grundlæggende forholdsregler, herunder følgende:



Læs, og følg:

**"FORHOLDSREGLER FOR AT UNDGÅ MULIG EKSPONERING FOR KRAFTIG MIKROBØLGEENERGI".**



Apparatet må bruges af børn på 8 år eller derover og personer med reducerede fysiske, sensoriske eller mentale evner, eller som mangler erfaring og viden, hvis de er under opsyn eller har modtaget instruktion i sikker brug af apparatet og forstår de involverede farer. Børn må ikke lege med apparatet. Rengøring og vedligeholdelse bør ikke udføres af børn uden overvågning.



Hold apparatet og ledningen uden for rækkevidden af børn under 8 år.

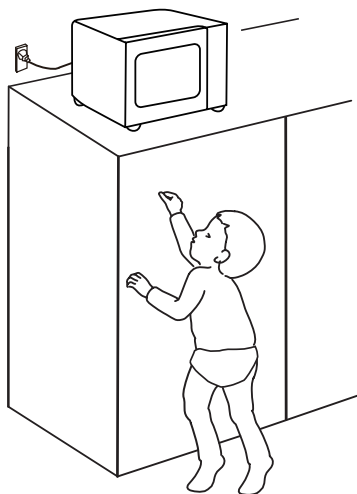

Hvis ledningen er beskadiget, skal den udskiftes af producenten,

# VIGTIGE SIKKERHEDSANVISNINGER

dennes serviceagent eller lignende kvalificerede personer for at undgå fare.

---

 **ADVARSEL:** Sørg for, at apparatet er slukket, før lampen udskiftes, for at undgå risikoen for elektrisk stød.

---

 **ADVARSEL:** Det er farligt for alle andre end kvalificerede personer at udføre service eller reparation, der indebærer fjernelse af et dæksel, der yder beskyttelse mod eksponering for mikrobølgeenergi.

---

 **ADVARSEL:** Væsker og andre fødevarer må ikke opvarmes i forseglede beholdere, da de kan eksplodere.

---

 Ved opvarmning af madvarer i plast- eller papbeholdere skal du holde øje med ovnen af hensyn til muligheden for antændelse.

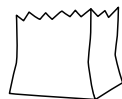

 Brug kun redskaber, der er egnede til brug i mikrobølgeovne.

---

 Hvis der udvikles røg, skal du slukke eller trække stikket ud af apparatet og holde døren lukket for at kvæle eventuelle flammer.

---

 Opvarmning af drikkevarer med mikrobølger kan medføre en forsinket pludselig opkogning. Der skal derfor udvises forsigtighed ved håndtering af beholderen.

---

 Indholdet i sutteflasker og glas med babymad skal omrøres eller rystes, og temperaturen skal

# VIGTIGE SIKKERHEDSANVISNINGER

kontrolleres for at undgå forbrændinger, før maden indtages.

 Ovnens skal rengøres regelmæssigt, og eventuelle madrester fjernes. Hold området omkring bølgeafdækningen rent. Brug en blød, fugtig klud til rengøring, når der er madrester i området omkring bølgeafdækningen eller i ovnrummet.

Manglende rengøring af madrester kan forårsage uskadelige gnister eller lidt røg i mikrobølgeovnrummet. Misfarvning af ovnrummet kan også forekomme.

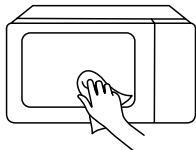

 Manglende rengøring af mikrobølgeovnen kan føre til ødelæggelse af overfladen, hvilket muligvis kan påvirke

ovnens levetid negativt og resultere i en farlig situation.

 Brug kun stegetemperaturspyddet, der anbefales til ovnen. (Gælder for ovne med en funktion til brug af stegetemperaturspyd).

 Når mikrobølgeovnen bruges, skal pyntedøren være åben. (gælder for ovne med pyntedør).

 Apparatet er beregnet til husholdningsbrug eller lignende anvendelse såsom:

1. Personalekøkkenområder i butikker, kontorer og andre arbejdsmiljøer.
2. Gæster på hoteller, moteller og andre beboelsesejendomme.
3. Landbrugsejendomme.
4. Gæsteboliger og pensionater.



# VIGTIGE SIKKERHEDSANVISNINGER

 Mikrobølgeovnen er beregnet til opvarmning af mad og drikkevarer. Tørring af madvarer eller beklædning og opvarmning af varmpuder, slippers, svampe, fugtige klude og lignende kan medføre risiko for personskade, antændelse eller ildebrand.

---

 Apparatets bagside skal placeres mod en væg.

---

 Temperaturen på tilgængelige overflader kan blive meget høj, når apparatet bruges.

---

 **ADVARSEL:** Når kombinationsprogrammet på apparatet bruges, må børn kun bruge ovnen under opsyn af en voksen på grund af de opnåede temperaturer.

 Apparatet er beregnet til at blive brugt fritstående.

---

 Hele æg med skal og hele hårdkogte æg må ikke opvarmes i mikrobølgeovnen, da de kan eksplodere, efter at opvarmningen med mikrobølger er afsluttet.

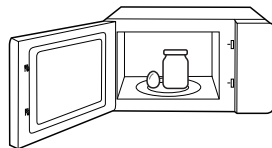

 Mikrobølgeovnen må ikke placeres i et skab, medmindre den er blevet testet i et skab.



---

 Metalbeholdere til mad og drikkevarer må ikke bruges under tilberedning med mikrobølger.

---

 Apparatet må ikke rengøres med damp.

# VIGTIGE SIKKERHEDSANVISNINGER

-  Apparatet er ikke beregnet til brug med en ekstern timer eller et separat fjernbetjeningssystem.
-  For at undgå overophedning må apparatet må ikke installeres bag en pyntedør. (Det gælder ikke for apparater med pyntedør).

LÆS BRUGERVEJLEDNINGEN  
OMHYGGELIGT, OG GEM DEN TIL  
SENERE BRUG

# INSTALLATION MED JORDFORBINDELSE FOR AT UNDGÅ RISIKO FOR PERSONSKADE

Apparatet skal jordforbindes. Jordforbindelsen reducerer risikoen for elektrisk stød ved at skabe en vej væk for strømmen i tilfælde af en elektrisk kortslutning.

Apparatet har en ledning med et jordstik. Stikket skal sættes i en stikkontakt, der er korrekt installeret og med jordforbindelse.

**ADVARSEL** – Ukorrekt brug af jordforbindelsen kan medføre fare for elektrisk stød. Kontakt en kvalificeret elektriker eller servicetekniker, hvis du ikke helt forstår anvisningerne om jordforbindelse, eller hvis du er tvivl om, hvorvidt apparatet er korrekt jordforbundet.

Hvis det er nødvendigt at bruge en forlængerledning, må du kun bruge en forlængerledning med tre ledninger.



**FARE**

Fare for elektrisk stød:

Det kan medføre alvorlig personskade eller død, hvis du rører ved nogle af de indvendige komponenter. Skil ikke apparatet ad.

# INSTALLATION MED JORDFORBINDELSE FOR AT UNDGÅ RISIKO FOR PERSONSKADE



## ADVARSEL

Fare for elektrisk stød:

Ukorrekt brug af jordforbindelsen kan medføre elektrisk stød. Sæt ikke stikket i en stikkontakt, før apparatet er korrekt installeret, og jordforbindelsen er etableret.

1. Den medfølgende ledning er gjort kort for at undgå risiko for en snoet ledning og forhindre, at personer kan snuble over ledningen.
2. Hvis der anvendes en lang ledning eller forlængerledning:
  - (1). Den angivne elektriske mærkning af ledningssættet eller forlængerledningen skal mindst svare til apparatets elektriske mærkning.
  - (2). Forlængerledningen skal have tre ledninger og skal jordforbindes.
  - (3). Den lange ledning skal være anbragt således, at den ikke hænger ud disken eller bordpladen, for at undgå, at børn kan trække i den, eller personer kan snuble over den.

# RENGØRING

Træk stikket ud af stikkontakten.

1. Rengør ovnrummet med en lettere fugtig klud.
2. Rengør tilbehøret med sæbevand.
3. Dørrammen og tætningen samt de tilstødende dele skal rengøres omhyggeligt med en fugtig klud, når de er snavsede.
4. Brug ikke skrappe, slibende rengøringsmidler eller skarpe metalskrabere til at rengøre glasset i ovndøren, da de kan ridse overfladen og medføre, at glasset splintrer.
5. Rengøringsråd – Nem rengøring af væggene i ovnrummet, som den tilberedte mad kan komme i kontakt med: Læg en halv citron i en skål, tilsæt 300 ml vand, og varm op på 100 % mikrobølgeeffekt i 10 minutter. Tør ovnen af med en blød, tør klud.

# KØKKENREDSKABER



**FORSIGTIG**

Fare for personskade:

Det er farligt for alle andre end kvalificerede personer at udføre service eller reparation, der indebærer fjernelse af et dæksel, der yder beskyttelse mod eksponering for mikrobølgeenergi. Se vejledningen om "**Materialer som kan bruges i mikrobølgeovn**" eller "**Materialer, der ikke kan bruges i mikrobølgeovn**".

Der kan være visse ikke-metalliske køkkenredskaber, som ikke er sikre at bruge i en mikrobølgeovn. Hvis du er i tvivl, kan du teste det pågældende køkkenredskab ved at følge nedenstående fremgangsmåde.

## Test af køkkenredskab:

1. Hæld en 1 kop koldt vand (250 ml) i en mikrobølgesikker beholder sammen med det pågældende redskab.
2. Kog på maksimal effekt i 1 minut.
3. Mærk forsigtigt på redskabet. Hvis det tomme køkkenredskab er varmt, må det ikke bruges til madlavning med mikrobølger.
4. Overskrid ikke kogetiden på 1 minut.

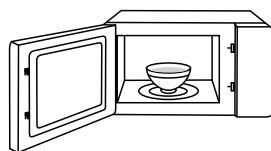

**BEMÆRK**

**HOLD OVNRUMMET OG  
OMRÅDET OMKRING  
BØLGEAFDÆKNINGEN RENT**

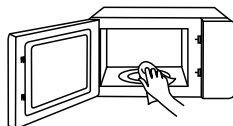

# MATERIALER SOM KAN BRUGES I MIKROBØLGEOVN

## KØKKENREDSKABER

## BEMÆRKNINGER



Bruningsfad

Følg producentens anvisninger.  
Bunden af bruningsfadet skal være mindst 5 mm over drejetallerkenen. Forkert brug kan medføre, at drejetallerkenen går i stykker.



Service

Kun service, der er mikrobølgesikkert.  
Følg producentens anvisninger.  
Brug ikke revnet eller skåret service.



Glaskrucker

Tag altid låget af. Brug kun til at opvarme mad, indtil den lige er varm. De fleste glaskrucker er ikke varmebestandige og kan gå i stykker.



Glasvarer

Kun varmebestandige glasvarer til ovn. Kontrollér, at der ikke er metallisk pynt. Brug ikke revnet eller skåret service.



Stegeposer

Følg producentens anvisninger. Må ikke lukkes med metalbånd.  
Skær revner, så dampen kan slippe ud.



Paptallerkner og kopper

Må kun anvendes til kortvarig madlavning/opvarmning. Lad ikke ovnen være uden opsyn under tilberedningen.



Køkkenrulle

Anvendes til at dække maden ved genopvarmning og til at opsuge fedt. Anvendes kun under opsyn til kortvarig madlavning.

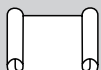

Pergamentpapir

Anvendes som låg for at forhindre stænk eller som indpakning til dampning.



# MATERIALER SOM KAN BRUGES I MIKROBØLGEOVN

## KØKKENREDSKABER

## BEMÆRKNINGER



Plast

Kun service, der er mikrobølgesikkert. Følg producentens anvisninger. Skal være mærket "Mikrobølgesikker". Nogle plastbeholdere bliver bløde, når maden i dem bliver varm. Der skal skæres eller stikkes hul i kogeposer og tæt tillukkede plastposer, eller de skal ventileres som beskrevet på emballagen.



Husholdningsfilm

Kun service, der er mikrobølgesikkert. Anvendes til at tildække maden under tilberedningen for at bevare væden. Husholdningsfilmen må ikke røre ved maden.

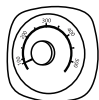

Termometre

Kun termometre, der er mikrobølgesikre (kød- og sliktermometre).



Vokspapir

Anvendes som låg for at forhindre stænk og holde på væden.





# MATERIALER, DER IKKE KAN BRUGES I MIKROBØLGEOVN

## KØKKENREDSKABER

## BEMÆRKNINGER

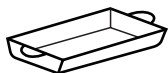

Aluminiumsbakke

Kan forårsage gnister. Flyt maden over på et mikrobølgesikkert fad.



Madkartoner med metalhåndtag

Kan forårsage gnister. Flyt maden over på et mikrobølgesikkert fad.



Metalredskaber eller redskaber med metalpynt

Metal afskærmer maden mod mikrobølgeenergi. Metalpynt kan forårsage gnister.



Metalbånd

Kan forårsage gnister og muligvis brand i ovnen.



Papirposer

Kan forårsage brand i ovnen.



Skumplast

Skumplast kan smelte eller forurene den indeholdte væske, når den udsættes for høj temperatur.



Træ

Træ tørrer ud, når det bruges i mikrobølgeovnen, og kan flække eller revne.



# INDSTILLING AF PRODUKT

## OPSÆTNING AF DIN OVN

### DELE OG TILBEHØR TIL MIKROBØLGEOVN

Tag ovnen og alle materialer ud af emballagen og af ovnrummet.

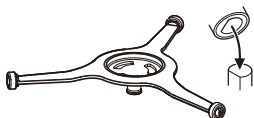

Enhed med ring til drejetallerken

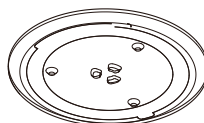

Drejetallerken af glas

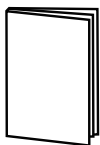

Brugervejledning

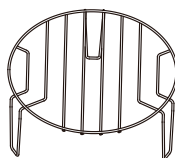

Grillrist (kan ikke bruges i mikrobølgeprogrammer og skal anbringes på drejetallerkenen af glas)

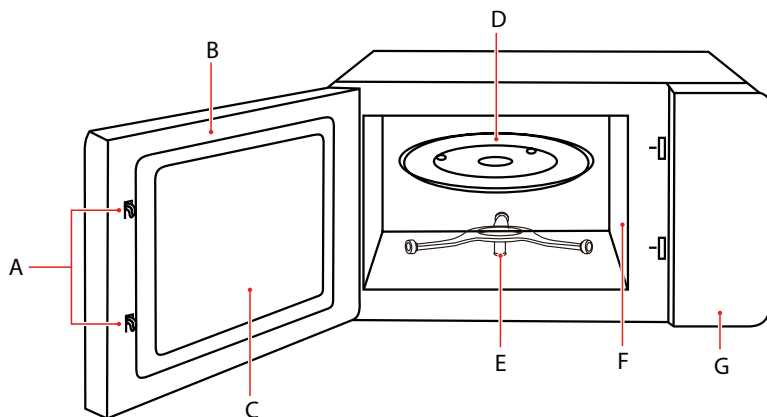

- A) Sikkerhedslåsesystem
- B) Dørnehed
- C) Inspektionsvindue
- D) Drejetallerken af glas

- E) Enhed med ring til drejetallerken
- F) Bølgeafdækning
- G) Kontrolpanel



I tilfælde af forskelle mellem apparatet og billederne i vejledningen gælder produktet.

# OPSÆTNING AF DIN OVN

## INSTALLATION AF DREJETALLERKEN

Rengør ovnrummet, og placér drejetallerkenen.

Ved nye installationer skal du sørge for, at al emballage og forsendelsestape er fjernet fra akslen til drejetallerkenen.

Før du første gang bruger apparatet til at tilberede mad, skal du sætte drejetallerkenen korrekt på plads. Du skal rengøre ovnrummet og tilbehøret. Du kan også henvise til rengøringsafsnittet.

Sådan sættes drejetallerkenen på plads:

1. Placér enheden med ringen til drejetallerkenen ② i fordybningen i ovnrummet.
2. Placér drejetallerkenen af glas ① på enheden med ringen til drejetallerken ②.

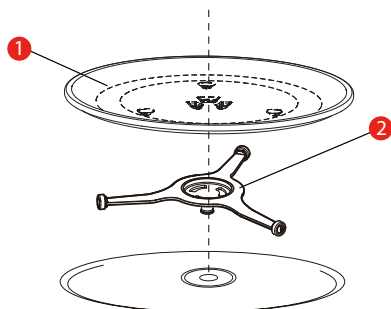

- 1) Drejetallerken af glas  
2) Enhed med ring til drejetallerken

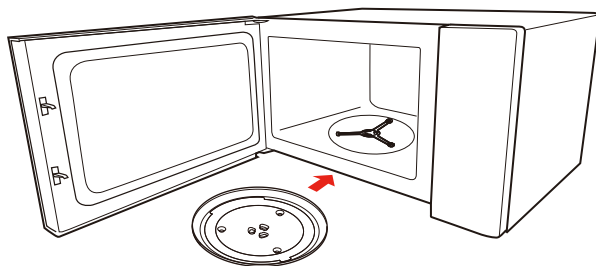

- Brug aldrig apparatet uden drejetallerkenen. Sørg for, at den er i korrekt indgreb. Drejetallerkenen kan dreje med eller mod uret.
- Vend aldrig drejetallerkenen af glas på hovedet. Drejetallerkenens rotation må aldrig begrænses.
- Både drejetallerkenen af glas og enheden med ring til drejetallerkenen skal altid bruges under tilberedningen.
- Al mad og beholdere med mad skal altid placeres på drejetallerkenen af glas for tilberedning.
- Begræns aldrig drejetallerkenens bevægelse.
- Kontakt dit nærmeste autoriserede servicecenter, hvis drejetallerkenen af glas eller enheden med ring til drejetallerkenen er revnet eller gået i stykker.

## INSTALLATION PÅ BORDPLADE

Fjern alt emballagemateriale og tilbehør. Undersøg ovnen for eventuelle skader såsom buler eller ødelagt dør. Installér ikke ovnen, hvis den er beskadiget.

Kabinettet: Fjern eventuel beskyttelsesfilm fra overfladen på kabinettet til mikrobølgeovnen. Fjern ikke bølgeafdækningen, der er fastgjort til ovnrummet for at beskytte magnetronen.

## INSTALLATION

1. Vælg en plan overflade med tilstrækkelig plads til indtogs- og/eller udtræksåbningerne.

a. Den mindste installationshøjde er 85 cm.

b. Apparatets bagside skal placeres mod en væg. Efterlad en afstand på mindst 30 cm over ovnen. Der kræves en afstand på mindst 20 cm mellem ovnen og eventuelle tilstødende vægge.

c. Fjern ikke benene fra bunden af ovnen.

d. Blokering af indtogs- og/eller udtræksåbninger kan beskadige ovnen.

e. Placér ovnen så langt væk fra radio- og tv-apparater som muligt. Brug af mikrobølgeovnen kan forårsage interferens i din radio- eller tv-modtagelse.

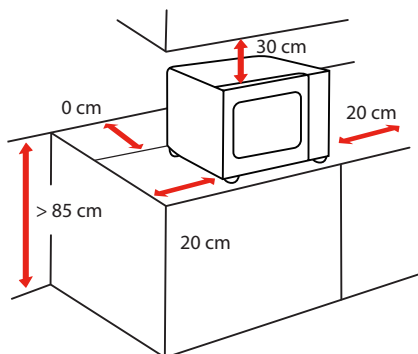

SIDE	AFSTAND CM
Top	30 cm
Venstre	20 cm
Højre	20 cm
Bagside	0 cm
Forside	Åbn

2. Sæt mikrobølgeovnen i en almindelig stikkontakt. Sørg for, at spændingen og frekvensen er den samme som spændingen og frekvensen på typemærkaten.



**BEMÆRK**

- Installér ikke mikrobølgeovnen over et komfur eller andre varmeproducerende apparater. Hvis den installeres i nærheden af eller over en varmekilde, kan ovnen blive beskadiget, og garantien ugyldiggøres.

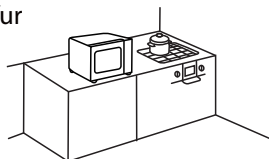

De tilgængelige overflader kan blive varme under brugen

## FØR FØRSTE IBRUGTAGNING

**Det er normalt, at ovnen udsender ubehagelige lugte, når den bruges første gang.**

Afsnittet beskriver, hvad du skal gøre, før du første gang bruger din mikrobølgeovn til at tilberede mad. Læs først afsnittet "**PRODUKTSIKKERHED**".

Før du kan bruge dit nye apparat, skal du sætte drejetallerkenen korrekt på plads. Du skal også rengøre ovnrummet og tilbehøret.



### BEMÆRK

- Brug aldrig apparatet uden drejetallerkenen.
- Sørg for, at den er i korrekt indgreb. Drejetallerkenen kan dreje med eller mod uret.

# BETJENING

## KONTROLPANEL OG FUNKTIONER

---

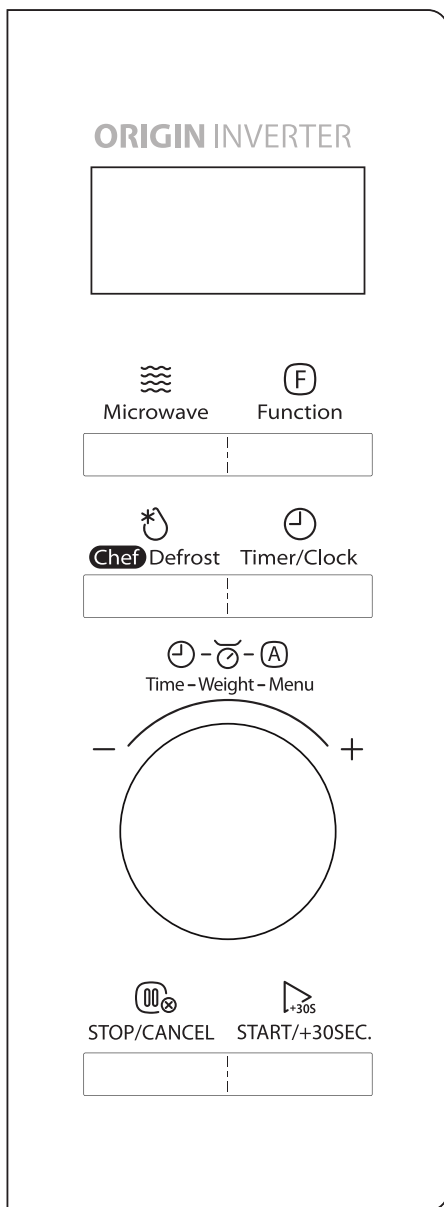

## 1. INDSTILLING AF URET

**a** Tryk to gange på  Timer/Clock. "00:00" vises.



**b** Drej knappen for at indstille timetallet.

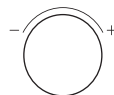

**c** Tryk på  Timer/Clock eller  START/+30SEC. for at bekræfte timetallet.





eller

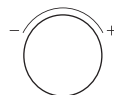

**d** Drej knappen for at indstille minuttallet.



**e** Tryk på  Timer/Clock eller  START/+30SEC. for at bekræfte. Uret er indstillet.



eller



### BEMÆRK

- Uret viser tiden i 24 timers format. Uret virker ikke, når apparatet tændes, hvis klokkeslættet ikke er indstillet.
- Gentag trin a-e for at nulstille uret.

## 2. INDSTILLING AF KØKKENTIMEREN

a Tryk på  Timer/Clock . "00:00" vises.



b Drej knappen for at indstille den ønskede tid.  
Den maksimale tid er "95:00".

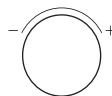

c Tryk på  START/+30SEC. for at bekræfte.  
Timeren begynder at tælle ned.



- Køkkentimeren er en timer.
- Ingen andre programmer kan indstilles under køkkentimeren.

## 3. TILBEREDNING MED MIKROBØLGER

Der findes 10 effektniveauer.

NIVEAU	EFFEKT	DISPLAY
1	100 %	P100
2	90 %	P90
3	80 %	P80
4	70 %	P70
5	60 %	P60
6	50 %	P50
7	40 %	P40
8	30 %	P30
9	20 %	P20
10	10 %	P10



**a** Tryk gentagne gange på  Microwave for at vælge effektniveau.



**eller**

Tryk på  Microwave, og drej derefter knappen for at indstille effektniveauet.





De 10 effekt niveauer er tilgængelige.

**b** Tryk på  START/+30SEC. for at bekræfte effektniveauet.

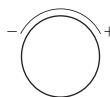

**c** Drej knappen for at indstille tilberedningstiden. Den maksimale tid er "95:00".



**d** Tryk på  START/+30SEC. for at starte tilberedningen.



## 4. TILBEREDNING MED GRILL

---

**a** Tryk på  Function. "G-1" vises.



**b** Tryk på  START/+30SEC. for at bekræfte programmet.



**c** Drej knappen for at indstille tilberedningstiden. Den maksimale tid er "95:00".

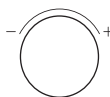

d Tryk på  for at starte tilberedningen.

  
START/+30SEC.



• Brummeren lyder for at minde dig om at vende maden under tilberedningen. Hvis du ikke foretager dig noget, fortsætter ovnen.

## 5. TILBEREDNING MED KOMBINATIONSPROGRAM

a Tryk gentagne gange på  for at vælge det ønskede tilberedningsprogram. "C-1" og "C-2" er tilgængelige.  
eller

  
Function

Tryk på , og drej derefter knappen for at vælge tilberedningsprogram.

  
Function



b Tryk på  for at bekræfte programmet.

  
START/+30SEC.

c Drej knappen for at indstille tilberedningstiden. Den maksimale tid er "95:00".

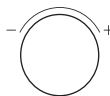

d Tryk på  for at starte tilberedningen.

  
START/+30SEC.

### DIAGRAM OVER KOMBINATIONSTILBEREDNING

PROGRAM	DISPLAY	MIKROBØLGEEFFEKT	GRILLEFFEKT
Kombination 1	C-1	55 %	45 %
Kombination 2	C-2	36 %	64 %

## 6. OPTØNING EFTER TID

- a Tryk på  "dEF1" vises.



- b Drej knappen for at indstille optøningstiden.  
Den maksimale tid er "95:00".

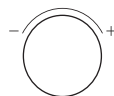

- c Tryk på  START/+30SEC. for at starte afrimningen.



### BEMÆRK

- Brummeren lyder for at minde dig om at vende maden under optøningen. Hvis du ikke foretager dig noget, fortsætter ovnen.
- Afrimningseffekten er P30, og den kan ikke ændres.

## 7. OPTØNING EFTER VÆGT

- a Tryk gentagne gange på  for at vælge type mad.  
Derefter vises "dEF2", "dEF3" eller "dEF4".



- b Drej knappen for at indstille vægten af maden.  
Den skal være inden for intervallet "100-2.000 g".

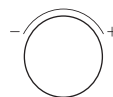

- c Tryk på  START/+30SEC. for at starte afrimningen.



LED-DISPLAY	MADVARE	VÆGT
dEF2	Kød	100-2.000 g
dEF3	Kylling	100-2.000 g
dEF4	Fisk	100-2.000 g



### BEMÆRK

- Brummeren lyder for at minde dig om at vende maden under optøningen. Hvis du ikke foretager dig noget, fortsætter ovnen.

## 8. HURTIG TILBEREDNING

**a** Drej knappen til venstre for at indstille en tilberedningstid med en effekt på 100 %.

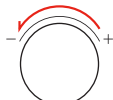

**b** Fortsæt med at dreje knappen for at indstille tilberedningstiden. Den maksimale tid er "95:00".



**c** Tryk på  for at starte tilberedningen.



**a** Tryk på  for at tilberede mad med 100 % effektniveau i 30 sekunder. Hvert tryk på den samme tast øger tiden med 30 sekunder, og den maksimale tid er "95:00".



## 9. TILBEREDNING I FLERE TRIN

Eksempel: Optø maden i fem minutter, og tilbered den derefter med 80 % mikrobølgeeffekt i syv minutter.

**a** Tryk på  "dEF1" vises.



**b** Drej knappen for at indstille den ønskede afrimningstid til fem minutter.



**c** Tryk gentagne gange på , indtil "P80" vises.



**d** Tryk på  for at bekræfte effektniveauet.



- e Drej knappen for at indstille tilberedningstiden til syv minutter.

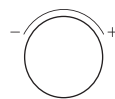

- f Tryk på  START/+30SEC. for at starte tilberedningen.



**BEMÆRK**

- Der kan indstilles to tilberedningstrin i tilberedelse i flere trin.
- Hvis du indstiller afrimningsfunktionen, fungerer den automatisk i første trin.
- Køkkentimeren, den automatiske menu og hurtigt tilberedelse kan ikke indstilles som et trin i tilberedelse i flere trin.

## 10. AUTOMATISK MENU

- a Drej knappen én gang til højre i standbytilstand, hvorefter "A-1" vises.

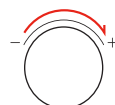

- b Drej knappen gentagne gange for at vælge menuen, som du har brug for. De syv automatiske menuer er tilgængelige.



- c Tryk på  START/+30SEC. for at bekræfte.



- d Drej knappen for at indstille vægten af maden.



- e Tryk på  START/+30SEC. for at starte tilberedningen.



## DIAGRAM OVER AUTOMATISK MENU

MENU	VÆGT/MÆNGDE	DISPLAY	EFFEKTNIVEAU
A-1 Popcorn	50 g 100 g	50 g 100 g	P100
A-2 Kartofler	1 (230 g) 2 (460 g) 3 (690 g)	1 2 3	P100
A-3 Pizza	200 g 400 g	200 g 400 g	P100
A-4 Frosne grøntsager	200 g 300 g 400 g	200 g 300 g 400 g	P100
A-5 Drikkevarer	1 kop (120 ml) 2 kopper (240 ml) 3 kopper (360 ml)	1 2 3	P100
A-6 Min tallerken (middagstallerken)	250 g 350 g 500 g	250 g 350 g 500 g	P100
A-7 Kød (svinekød)	250 g 350 g 450 g	250 g 350 g 450 g	P80

## 11. BØRNELÅS

---

Du kan bruge funktionen til at forhindre børn i ved et uheld at tænde ovnen.

- a** Sådan aktiveres låsen:

Tryk på  i tre sekunder i standbytilstand.

Der lyder et bip, og låseikonet vises.



- b** Sådan deaktiveres låsen:

Tryk på  i tre sekunder i låst tilstand.

Der lyder et bip.



## 12. OPLYSNINGSFUNKTION

---

- a** Tryk på  Timer/Clock, når ovnen er i brug.

Den aktuelle tid vises i displayet i tre sekunder.



- b** I tilberedningsprogrammet med mikrobølger skal du trykke på  for at få vist effektniveauet. Oplysningen vises i tre sekunder.



- c** I grill- og kombinationstilberedningsprogrammet skal du trykke på  for at få oplyst tilberedningsprogrammet. Oplysningen vises i tre sekunder.



# RENGØRING OG VEDLIGEHOLDELSE

## RENGØRING

Ovnens beholder sit udseende med god pleje og rengøring og kan bruges i mange år fremover. Vi forklarer her, hvordan du skal pleje og rengøre dit apparat korrekt.



**ADVARSEL**

- Ridset glas i ovndøren kan udvikle sig til en revne. Brug ikke en glasskraber, skrappe eller slibende rensmidler eller rengøringsmidler.
- Apparattets overflade kan blive beskadiget, hvis det ikke rengøres korrekt. Mikrobølgeenergi kan slippe ud. Rengør apparatet regelmæssigt, og fjern straks eventuelle madrester.
- Læg ikke apparatet i vand, og rengør ikke apparatet med en vandstråle.

## Rensemiddel

Følg oplysningerne i tabellen for at sikre, at de forskellige overflader ikke beskadiges ved at bruge det forkerte rensmiddel. Vask nye svampeklude grundigt før brug.

### Brug ikke:



Skrappe eller slibende rensmidler



Metal- eller glasskrabere til rengøring af dørpanelerne



Metal- eller glasskrabere til rengøring af dørforseglingen



Hårde skurepuder eller svampe



Rensemiddel med et højt alkoholindhold

## APPARATETS FORSIDE

### Varmt sæbevand:

Rengør med et viskestykke, og tør derefter af med en blød klud. Brug ikke metal- eller glasskrabere til rengøringen.

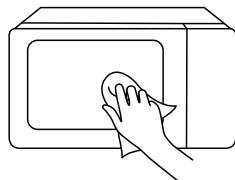



## FORSIDE PÅ APPARAT MED RUSTFRIT STÅL

---

### Varmt sæbevand:

Rengør med et viskestykke, og tør derefter af med en blød klud. Fjern straks stænk og pletter af kalk, fedt, stivelse og æggehvite. Der kan dannes rust under disse pletter eller stænk. Brug ikke glasrensemiddel eller metal- eller glasskrabere til rengøringen.

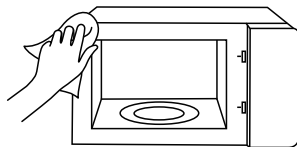

## OVNRUM AF RUSTFRIT STÅL

---

### Varmt sæbevand eller eddikeopløsning:

Rengør med et viskestykke, og tør derefter af med en blød klud. Brug ikke ovnspray, aggressive ovnrensere eller slibende materialer. Skurepuder, ru svampe og panderensmidler er også uegnede. De ridser overfladen. Lad de indvendige overflader tørre helt.

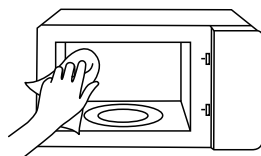

## FORDYBNING I OVNRUMMET

---

### Fugtig klud:

Der må ikke løbe vand ind i apparatet gennem drevet til drejetallerkenen. Tør drejetallerkenen med en klud.

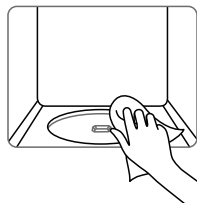

## DREJETALLERKEN OG RULLERING

---

### Varmt sæbevand:

Når drejetallerkenen sættes tilbage i fordybningen, skal den gå i korrekt indgreb.

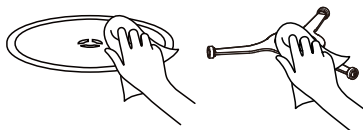

## DØRPANELER

---

### Glasrensemiddel:

Rengør med et viskestykke. Brug ikke glasskrabere.

# FEJLFINDING

Tjek dit problem ved hjælp af nedenstående diagram, og prøv løsningerne til problemet. Hvis mikrobølgeovnen stadig ikke fungerer korrekt, skal du kontakte det nærmeste autoriserede servicecenter.

PROBLEM	MULIG ÅRSAG	MULIG LØSNING
Ovnen starter ikke	a. Ovnens ledning er ikke sat i. b. Døren er åben. c. Forkert program er indstillet.	a. Sæt stikket i stikkontakten. b. Luk døren, og prøv igen. c. Kontrollér vejledningen
Lysbue eller gnistdannelse	a. Der blev anvendt materialer, der skal undgås i en mikrobølgeovn. b. Ovnen er brugt, når den er tom. c. Spildt mad i ovnrummet.	a. Brug kun mikrobølgesikkert køkkengrej. b. Brug ikke ovnen, når den er tom. c. Rengør ovnrummet med en blød, fugtig klud.
Uensartet tilberedt mad	a. Der blev anvendt materialer, der skal undgås i en mikrobølgeovn. b. Maden er ikke helt optøet. c. Tilberedningstid eller effektniveau er ikke egnet. d. Maden er ikke vendt, eller der er ikke rørt rundt i den.	a. Brug kun mikrobølgesikkert køkkengrej. b. Optø maden helt. c. Brug korrekt tilberedningstid og effektniveau. d. Vend, eller rør i maden.
Overtilberedt mad	Tilberedningstid eller effektniveau er ikke egnet.	Brug korrekt tilberedningstid og effektniveau.
Undertilberedt mad	a. Der blev anvendt materialer, der skal undgås i en mikrobølgeovn. b. Maden er ikke helt optøet. c. Ventilationsåbningerne i ovnen er blokerede. d. Tilberedningstid eller effektniveau er ikke egnet.	a. Brug kun mikrobølgesikkert køkkengrej. b. Optø maden helt. c. Kontrollér, at ventilationsåbningerne i ovnen ikke er blokerede. d. Brug korrekt tilberedningstid og effektniveau
Ukorrekt afrimning	a. Der blev anvendt materialer, der skal undgås i en mikrobølgeovn. b. Tilberedningstid eller effektniveau er ikke egnet. c. Maden er ikke vendt, eller der er ikke rørt rundt i den.	a. Brug kun mikrobølgesikkert køkkengrej. b. Brug korrekt tilberedningstid og effektniveau. c. Vend, eller rør i maden.



I henhold til WEEE-direktivet (direktivet om affald af elektrisk og elektronisk udstyr) skal affald af elektrisk og elektronisk udstyr indsamles og behandles separat. Hvis du på et tidspunkt i fremtiden skal bortskaffe produktet, må det IKKE bortskaffes sammen med husholdningsaffald. Send produktet til indsamlingssteder for affald af elektrisk og elektronisk udstyr, hvor disse findes.



**#DetailsMatter**

**GEBRUIKSHANDLEIDING**

# **MAGNETRONOVEN**

MW3-AG25PFI(MG)

Lees deze gebruikshandleiding voordat u deze in gebruik neemt.

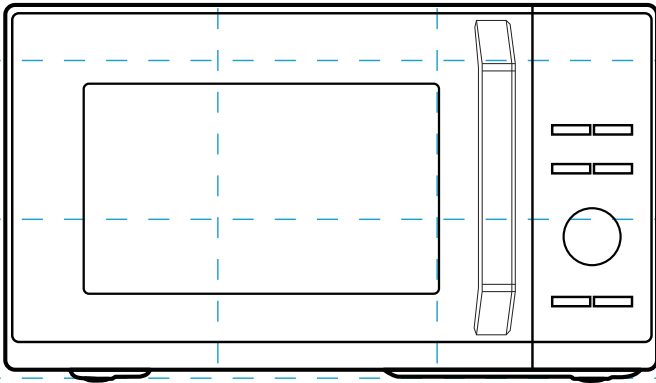

**TOSHIBA**

# INHOUD

## PRODUCTVEILIGHEID

Voorzorgsmaatregelen ter voorkoming van mogelijke blootstelling aan teveel microgolvenenergie .....	NL-01
Specificaties .....	NL-02
Belangrijke veiligheidsinstructies .....	NL-03
Aardingsinstallatie om het risico op persoonlijk letsel te verminderen .....	NL-08
Reinigen .....	NL-10
Keukengerei .....	NL-11
Materialen die u in de magnetronoven kunt gebruiken .....	NL-12
Materialen die u niet in de magnetron kunt gebruiken .....	NL-14

## PRODUCTINSTELLING

Uw oven instellen .....	NL-15
-------------------------	-------

## GEBRUIKSINSTRUCTIES

Voor het eerste gebruik .....	NL-18
Bediening .....	NL-19
Bedieningspaneel en functies .....	NL-19
1. De klok instellen .....	NL-20
2. De kooktimer instellen .....	NL-21
3. Koken met de magnetron .....	NL-21
4. Koken met de grill .....	NL-22
5. Koken met de combinatiefunctie .....	NL-23
6. Ontdooien op tijd .....	NL-24
7. Ontdooien op gewicht .....	NL-24
8. Snel koken .....	NL-25
9. Koken met meerdere fasen .....	NL-25

10. Automatisch menu .....	NL-26
11. Kinderslotfunctie .....	NL-28
12. Controlefunctie .....	NL-28

## REINIGING EN ONDERHOUD

Reinigen .....	NL-29
Probleemoplossing .....	NL-31



### OPMERKING

LEES, BEGRIJP EN VOLG DEZE INSTRUCTIES  
VOORDAT U DIT PRODUCT IN GEBRUIK NEEMT.  
BEWAAR DEZE DOCUMENTATIE VOOR  
TOEKOMSTIGE REFERENTIE.

# PRODUCTVEILIGHEID

## VOORZORGSMAATREGELEN TER VOORKOMING VAN MOGELIJKE BLOOTSTELLING AAN TEVEEL MICROGOLFENERGIE

---

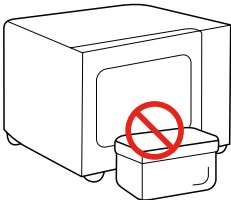
- (a). Probeer deze oven niet te gebruiken met een geopende deur, omdat dit kan leiden tot blootstelling aan schadelijke microgolven. Het is belangrijk om de veiligheidsvergrendelingen niet te breken of eraan te knoeien.
- (b). Plaats geen voorwerpen tussen de voorkant van de oven en de deur en laat geen vuil of reinigingsresten ophopen op de afdichtingsoppervlakken.
- 
- (c). **WAARSCHUWING:** Als de deur of deurafdichtingen zijn beschadigd, mag de oven niet langer worden gebruikt totdat deze is gerepareerd door een vakman.

### ADDENDUM

---

Als het apparaat niet goed schoon wordt gehouden, kan kunnen de oppervlaktes ervan degraderen waardoor de levensduur van het apparaat wordt ingekort en er gevaarlijke situaties kunnen optreden.



## SPECIFICATIES

---

MODEL	MW3-AG25PFI(MG)
NOMINALE SPANNING/FREQUENTIE	230-240 V~ 50 Hz
INGANGSVERMOGEN MAGNETRON	1400 W
UITGANGSVERMOGEN MAGNETRON	900 W
NOMINAAL INGANGSVERMOGEN (GRILL)	1000-1100 W



### OPMERKING

Alle afbeeldingen in deze handleiding dienen slechts ter illustratie, deze kunnen enigszins afwijken van de gekochte apparatuur. Raadpleeg het daadwerkelijke product.

# BELANGRIJKE VEILIGHEIDSIINSTRUCTIES



## WAARSCHUWING

Om het risico op brand, elektrische schokken, persoonlijk letsel of blootstelling aan overmatige microgolfoverenergie te verminderen wanneer u uw apparaat gebruikt, dient u bepaalde algemene voorzorgsmaatregelen te treffen, waaronder de volgende:



Lees en volg de gespecificeerde: **"VOORZORGSMAATREGEN TER VOORKOMING VAN MOGELIJKE BLOOTSTELLING AAN TEVEEL MICROGOLFENERGIE"**.



Dit apparaat kan worden gebruikt door kinderen van 8 jaar en ouder en door personen met verminderde fysieke, zintuiglijke of mentale capaciteiten, of met een tekort aan kennis en ervaring, vooropgesteld dat zij onder toezicht staan of instructies hebben gekregen m.b.t. het veilige gebruik van het apparaat en de bijbehorende gevaren begrijpen. Kinderen mogen niet met het apparaat spelen. Reiniging en gebruiksonderhoud mag niet zonder toezicht worden uitgevoerd door kinderen.



Houd het apparaat en de kabel ervan buiten bereik van kinderen jonger dan 8 jaar.

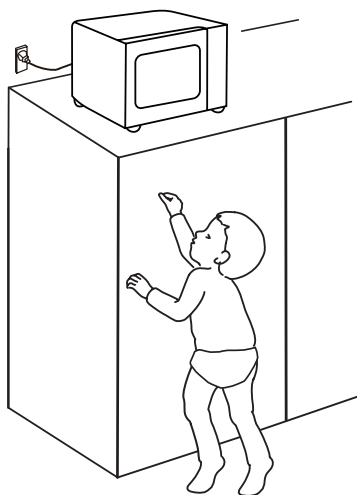

Als het stroomsnoer is beschadigd, moet deze door de fabrikant, een onderhoudsvertegenwoordiger

# BELANGRIJKE VEILIGHEIDSINSTRUCTIES

of een vergelijkbaar, gekwalificeerd persoon worden vervangen om gevaar te voorkomen.

---

 **WAARSCHUWING:** Zorg ervoor het apparaat uit te schakelen voordat u de lamp vervangt, om de kans op een elektrische schok te vermijden.

---

 **WAARSCHUWING:** Het is voor iedereen anders dan een bevoegd persoon gevaarlijk om onderhouds- of reparatiewerkzaamheden uit te voeren waarbij een afdekking moet worden verwijderd die bescherming biedt tegen blootstelling aan microgolvenenergie.

---

 **WAARSCHUWING:** Vloeistoffen en ander voedsel mogen niet worden opgewarmd in afgesloten containers, omdat deze kunnen ontploffen.

 Houd bij het verwarmen van voedsel in plastic of papieren bakjes de oven goed in de gaten, omdat deze in brand kunnen vliegen.



---

 Gebruik alleen keukengerei dat geschikt is voor gebruik in magnetronovens.

---

 Als er rook uit het apparaat komt, schakel deze dan uit of trek de stekker uit het stopcontact en houd de deur gesloten om eventuele vlammen te doven.

---

 Drank dat in de magnetron wordt verwarmd kan vertraagd beginnen te koken, daarom moet de container voorzichtig worden gehanteerd.

---

 De inhoud van zuigflessen en potjes babyvoeding moet vóór consumptie worden geroerd of geschud

# BELANGRIJKE VEILIGHEIDSSINSTRUCTIES

en de temperatuur moet worden gecontroleerd om brandwonden te voorkomen.

 De oven moet regelmatig worden schoongemaakt en eventuele voedselresten moeten worden verwijderd. Houd het gebied van de golfgeleider schoon. Gebruik een zachte vochtige doek om het op te ruimen wanneer er etensresten achterblijven op het gebied van de golfgeleider of de holte. Het niet reinigen van voedselresten kan onschadelijke vonken of wat rook in de magnetronholte veroorzaken, er kan ook verkleuring van de holte optreden.

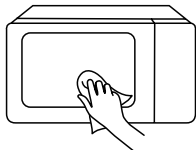

 Als u de oven niet schoon houdt, kan dit leiden tot aantasting van het oppervlak, wat de levensduur van het apparaat inkort en mogelijk

tot een gevaarlijke situatie leidt.

---

 Gebruik uitsluitend de temperatuursonde aanbevolen voor deze oven. (voor ovens die de mogelijkheid bieden om een temperatuursonde te gebruiken.)

---

 De magnetronoven moet worden gebruikt met geopende decoratieve deur. (voor ovens met een decoratieve deur.)

---

 Dit apparaat is bedoeld voor huishoudelijk en vergelijkbaar gebruik, zoals:

1. personeelskantines in werkplaatsen, op kantoor of in andere werkomgevingen;
2. door gasten in hotels, motels en andere woonomgevingen;
3. boerderijen;
4. omgevingen zoals bed and breakfasts.

# BELANGRIJKE VEILIGHEIDSINSTRUCTIES

 De magnetron is bestemd voor het verwarmen van voedsel en dranken. Het drogen van voedsel of kleding en het opwarmen van verwarmingskussens, pantoffels, sponzen, vochtige doeken en dergelijke kan leiden tot letsel, ontbranding of brand.

---

 De achteroppervlakte van het apparaat dient tegen een muur te worden geplaatst.

---

 De temperatuur van toegankelijke oppervlakken kan hoog zijn wanneer het apparaat werkzaam is.

---

 **WAARSCHUWING:** Als het apparaat in de combinatiestand wordt gebruikt, mogen kinderen de oven vanwege de gegenereerde temperaturen alleen onder toezicht van een volwassene gebruiken.

 Het apparaat is bestemd voor vrijstaand gebruik.

---

 Eieren in hun schaal en hele hardgekookte eieren mogen niet in magnetrons worden verwarmd, omdat deze kunnen ontploffen, zelfs nadat de verwarming in de magnetron is geëindigd.

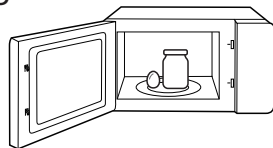

 De magnetronoven mag niet in een kast worden geplaatst, tenzij deze in een kast is getest.

---

 Metalen bakjes voor eten en drinken zijn niet toegestaan tijdens het koken in de magnetron.

---

 Maak het apparaat niet schoon met een stoomreiniger.

# BELANGRIJKE VEILIGHEIDSINSTRUCTIES

 De apparaten zijn niet bedoeld voor bediening door middel van een externe timer of een afzonderlijk afstandsbedieningssysteem.

 Het apparaat mag niet achter een decoratieve deur worden geïnstalleerd om oververhitting te voorkomen. (Dit geldt niet voor apparaten met decoratieve deur.)

ZORGVULDIG LEZEN EN BEWAREN  
VOOR TOEKOMSTIGE REFERENTIE

# AARDINGSINSTALALTIJE OM HET RISICO OP PERSOONLIJK LETSEL TE VERMINDEREN

Dit apparaat moet worden geaard. In het geval van een elektrische kortsluiting, vermindert aarding het risico op elektrische schokken omdat de elektrische stroom in dit geval een ontsnappingsdraad heeft.

Dit apparaat is uitgerust met een snoer voorzien van een aardingsdraad met gearde stekker. De stekker moet in een stopcontact worden gestoken dat correct is geïnstalleerd en geaard.

**WAARSCHUWING** - Onjuist gebruik van de aarding kan leiden tot een elektrische schok. Raadpleeg een gekwalificeerde elektricien of onderhoudsmonteur als u de instructies voor de aarding niet volledig begrijpt of als u twijfelt of het apparaat correct is geaard. Als het nodig is een verlengsnoer te gebruiken, gebruik dan uitsluitend een 3-aderig verlengsnoer.



**GEVAAR**

Risico op elektrische schok:  
Het aanraken van bepaalde interne onderdelen kan tot ernstig of zelfs fataal letsel leiden. Demonteer dit apparaat niet.

# AARDINGSINSTALALTIJE OM HET RISICO OP PERSOONLIJK LETSEL TE VERMINDEREN



## WAARSCHUWING

Risico op elektrische schok:

Onjuist gebruik van de aarding kan leiden tot een elektrische schok. Sluit niet aan op een stopcontact totdat het apparaat goed geïnstalleerd en geaard is.

1. Er is een kort netsnoer meegeleverd om het risico te verkleinen dat u verstrikt raakt in of struikelt over een langer snoer.

2. Als een lang netsnoer of verlengsnoer wordt gebruikt:

- (1). Het gemarkeerde elektrische vermogen van het snoer of het verlengsnoer moet minstens even hoog zijn als het elektrische vermogen van het apparaat.
- (2). Het verlengsnoer moet een geaard 3-aderige kabel zijn.
- (3). Het lange snoer moet zo worden geplaatst dat het niet over het aanrechtblad of tafelblad kan vallen, waar kinderen eraan kunnen trekken of er per ongeluk over kunnen struikelen.



# REINIGEN

Zorg ervoor het apparaat los te koppelen van de voeding.

1. Maak de ovenruimte na gebruik schoon met een ietwat vochtig doekje.
2. Reinig het toebehoren op de gebruikelijke manier in een sopje.
3. Maak het deurframe, de afdichting en aangrenzende onderdelen voorzichtig schoon met een vochtig doekje wanneer deze vuil zijn geworden.
4. Gebruik geen agressieve schoonmaakmiddelen of scherpe metalen schrapers om het glas van de oven deur schoon te maken, aangezien deze krassen op het oppervlak kunnen veroorzaken waardoor het glas kan breken.
5. Tip voor reiniging---Om de binnenwanden die het gekookte voedsel kan aanraken gemakkelijker te reinigen: Plaats een halve citroen in een kom, voeg 300 ml (1/2 pint) water toe en verwarm gedurende 10 minuten op 100% magnetronvermogen. Veeg de oven schoon met een zachte, droge doek.

# KEUKENGEREI



Risico op persoonlijk letsel:  
Het is voor iedereen anders dan een bevoegd persoon gevaarlijk om onderhouds- of reparatiewerkzaamheden uit te voeren waarbij een afdekking moet worden verwijderd die bescherming biedt tegen blootstelling aan microgolvenenergie. Zie de instructies onder "**Materialen die u in de magnetronoven kunt gebruiken**" of "**Materialen die u niet in de magnetronoven kunt gebruiken**".  
Er kunnen bepaalde niet-metalen gebruiksvoorwerpen zijn die onveilig zijn om in de magnetron te worden gebruikt. Als u twijfelt, kunt u het betreffende keukengerei volgens de onderstaande procedure testen.

## Test voor keukengerei:

1. Vul een magnetronbestendige container met 1 kopje koud water (250 ml) samen met het betreffende keukengerei.
2. Kook op maximaal vermogen gedurende 1 minuut.
3. Raak het keukengerei voorzichtig aan. Als het lege keukengerei leeg is, gebruik deze dan niet voor het koken in de magnetron.
4. Niet langer dan 1 minuut koken.

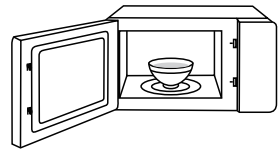

HOUD DE HOLTE EN HET  
GEBIED VAN DE  
GOLFGELEIDER SCHOON

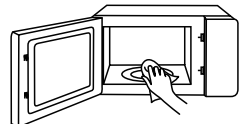

# MATERIALEN DIE U IN DE MAGNETRONOVEN KUNT GEBRUIKEN

## KEUKENGEREI

## OPMERKINGEN



Ovenschaal

Volg de instructies van de fabrikant.  
De onderkant van de ovenschaal moet zich minstens 5 mm (3/16 inch) boven het draaiplateau bevinden. Het draaiplateau kan breken bij incorrect gebruik.



Serviesgoed

Alleen magnetronbestendig. Volg de instructies van de fabrikant. Gebruik geen gebarsten of geschilderd serviesgoed.



Glazen potten

Verwijder altijd het deksel. Gebruik alleen om voedsel te verwarmen totdat het net warm is. De meeste glazen potten zijn niet hittebestendig en kunnen breken.



Glaswerk

Uitsluitend hittebestendig glaswerk voor ovens. Zorg ervoor dat er geen metalen rand is. Gebruik geen gebarsten of geschilderd serviesgoed.



Kookzakken voor ovens

Volg de instructies van de fabrikant. Sluit niet met metalen binders. Maak sleufjes om stoom te laten ontsnappen.



Papieren borden en koppen

Alleen gebruiken voor kort koken/opwarmen. Laat de oven tijdens het koken niet onbeheerd achter.



Keukenrol

Om voedsel af te dekken en op te warmen en vet te absorberen. Gebruik onder toezicht alleen voor kort koken.

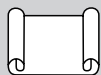

Bakpapier

Gebruik als afdekking om spatten te voorkomen of om te stomen.



# MATERIALEN DIE U IN DE MAGNETRONOVEN KUNT GEBRUIKEN

## KEUKENGEREI

## OPMERKINGEN



Plastic

Alleen magnetronbestendig. Volg de instructies van de fabrikant. Het moet gemarkeerd staan met "Magnetronbestendig". Sommige plastic containers worden zachter naargelang het voedsel erin heet wordt. "Kookzakken" en goed gesloten plastic zakken moeten worden doorsneden, doorgeprikt of geventileerd zoals aangegeven op de verpakking.



Huishoudfolie

Alleen magnetronbestendig. Gebruik om voedsel tijdens het koken af te dekken en vocht te behouden. Laat de huishoudfolie het voedsel niet aanraken.

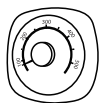

Thermometers

Alleen magnetronbestendig (vlees- en snoepthermometers).



Waspapier

Gebruik als afdekking om spatten te voorkomen en vocht te behouden.



# MATERIALEN DIE U NIET IN DE MAGNETRON KUNT GEBRUIKEN

## KEUKENGEREI

## OPMERKINGEN



Aluminium plaat

Kan vonken veroorzaken. Plaats het voedsel in een magnetronbestendige schaal.



Voedselkarton met metalen handvat

Kan vonken veroorzaken. Plaats het voedsel in een magnetronbestendige schaal.



Keukengerei van metaal of met metalen rand

Metaal beschermt het voedsel tegen microgolfenergie. Metalen randen kunnen vonken veroorzaken.



Metalen binders

Kunnen vonken en brand in de oven veroorzaken.



Papieren zakken

Kunnen brand in de oven veroorzaken.



Schuimplastic

Schuimplastic kan smelten of de vloeistof binnenin vervuilen als het wordt blootgesteld aan hoge temperaturen.



Hout

Hout zal uitdrogen bij gebruik in de magnetron en kan splijten of barsten.



# PRODUCTINSTELLING

## UW OVEN INSTELLEN

### NAMEN VAN MAGNETRONONDERDELEN EN -ACCESSOIRES

Haal de oven en alle materialen uit de doos en ovenruimte.

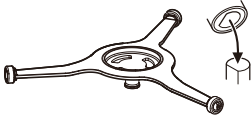

Ring voor draaiplateau

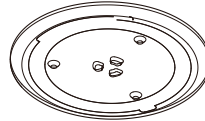

Glazen Plateau

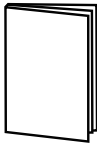

Gebruikshandleiding

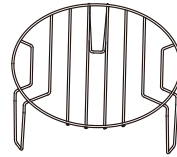

Grillrek (kan niet worden gebruikt met de magnetronfunctie en moet op het glazen plateau worden geplaatst)

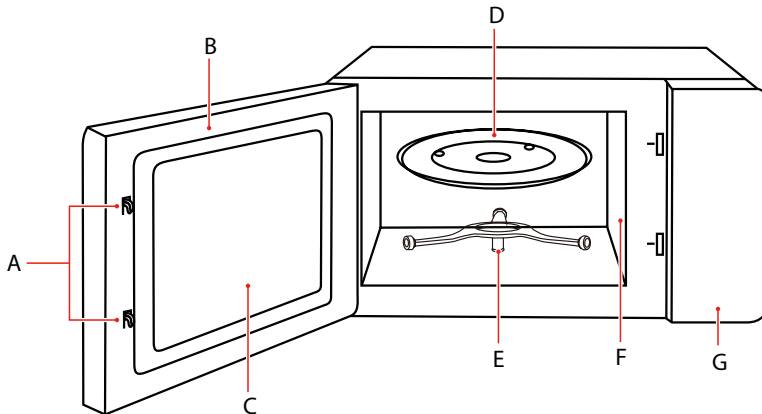

- A) Vergrendelsysteem voor veiligheid
- B) Deurasssemblage
- C) Kijkvenster
- D) Glazen plateau

- E) Ringmontage voor draaiplateau
- F) Afdekking van de golfgeleider
- G) Bedieningspaneel



In geval van verschillen tussen het apparaat en de afbeeldingen in deze handleiding, krijgt het product voorrang.

# UW OVEN INSTELLEN

## DRAAIPLATEAU-INSTALLATIE

Reinig het kookcompartiment en plaats het draaiplateau.

Voor nieuwe installaties, zorg ervoor dat alle verpakking en tape is verwijderd van de as van het draaiplateau.

Voordat u het apparaat gebruikt om voor de eerste keer voedsel te bereiden, moet u het draaiplateau correct plaatsen. U moet het kookcompartiment en de accessoires reinigen. U kunt ze ook doorverwijzen naar het schoonmaakgedeelte.

Het draaiplateau plaatsen:

1. Plaats de ringmontage van het draaiplateau ② in de uitsparing in het kookcompartiment.
2. Plaats het glazen plateau ① op de ringmontages van het draaiplateau ②.

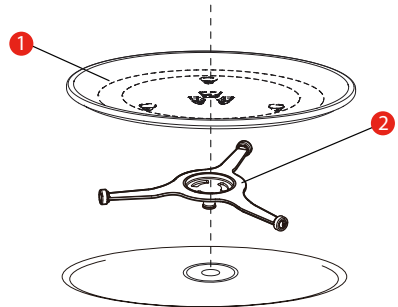

- 1) Glazen draaiplateau  
2) Ring voor draaiplateau

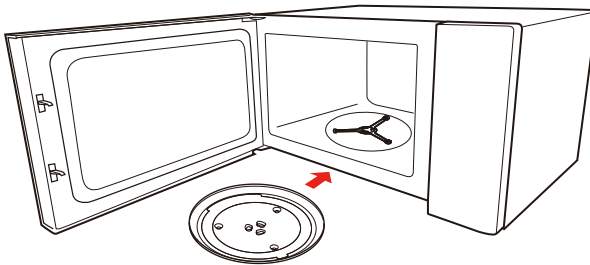

### OPMERKING

- Gebruik het apparaat nooit zonder de draaiplateau. Zorg ervoor dat het correct is geplaatst. Het draaiplateau kan rechtsom en linksom draaien.
- Plaats het glazen plateau nooit ondersteboven. Het glazen plateau mag niet worden geblokkeerd.
- Zowel het glazen plateau als de ring voor het draaiplateau moet tijdens het koken worden gebruikt.
- Alle etenswaren en bakjes met etenswaren worden altijd op het glazen plateau geplaatst om te koken.
- Beperk de beweging van het draaiplateau niet.
- Neem contact op met het dichtstbijzijnde geautoriseerde servicecentrum als het glazen plateau of de ring van het draaiplateau scheurt of breekt.

## KEUKENBLADINSTALLATIE

Verwijder al verpakkingsmateriaal en toebehoren. Inspecteer de oven op eventuele schade, zoals deuken of een gebroken deur. Installeer de oven niet als deze beschadigd is.

Behuizing: Verwijder alle beschermplaagjes op de behuizing van de magnetronoven. Verwijder niet de afdekking van de golfgeleider die aan de ovenholte is bevestigd om de magnetron te beschermen.

## INSTALLATIE

1. Kies een vlak oppervlak met voldoende open ruimte voor de inlaat- en/of uitlaatopeningen voor ventilatie.
  - a. De minimale installatiehoogte is 85 cm.
  - b. Het achteroppervlak van het apparaat moet tegen een muur worden geplaatst. Laat een minimumafstand van 30 cm boven de oven. Tussen de oven en de aangrenzende muren is een minimale ruimte van 20 cm vereist.
  - c. Verwijder niet de poten uit de onderzijde van de oven.
  - d. De oven kan beschadigd raken als de inlaat- en/of uitlaatopeningen worden geblokkeerd.
  - e. Plaats de oven zo ver mogelijk uit de buurt van radio's en tv's. De werking van een magnetronoven kan storing veroorzaken in uw radio- of tv-ontvangst.

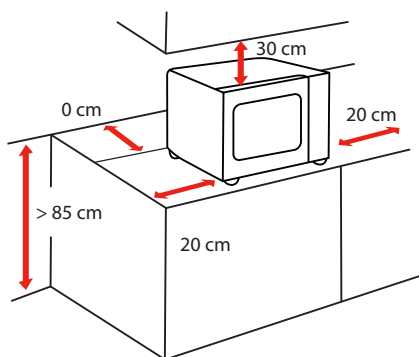

ZIJKANT	AFSTAND CM
Bovenkant	30 cm
Links	20 cm
Rechts	20 cm
Achter	0 cm
Voorkant	Open

2. Sluit de magnetron aan op een standaard huishoudelijk stopcontact. Controleer of de spanning en frequentie hetzelfde zijn als de spanning en frequentie aangegeven op het typeplaatje.



**OPMERKING**

- Installeer de oven niet boven een fornuis of een ander apparaat dat warmte produceert. Indien geïnstalleerd in de buurt van of boven een warmtebron, kan de oven beschadigd raken en vervalt de garantie.

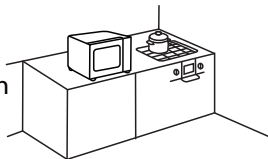

Het toegankelijke oppervlak kan tijdens gebruik heet zijn



# GEBRUIKSIINSTRUCTIES

## VOOR HET EERSTE GEBRUIK

**Het is normaal dat het apparaat een onaangename geur kan verspreiden wanneer het voor de eerste keer wordt gebruikt.**

In dit hoofdstuk leest u wat u moet doen voordat u uw magnetron voor de eerste keer gebruikt om voedsel te bereiden. Lees eerst het hoofdstuk "**VEILIGHEIDSINFORMATIE**".

Voordat u uw nieuwe apparaat kunt gebruiken, moet u het draaiplateau correct plaatsen. U moet ook het kookcompartiment en de accessoires reinigen.



### OPMERKING

- Gebruik het apparaat nooit zonder de draaiplateau.
- Zorg ervoor dat het correct is geplaatst. Het draaiplateau kan rechtsom en linksom draaien.

# BEDIENING

## BEDIENINGSPANEEL EN FUNCTIES

---

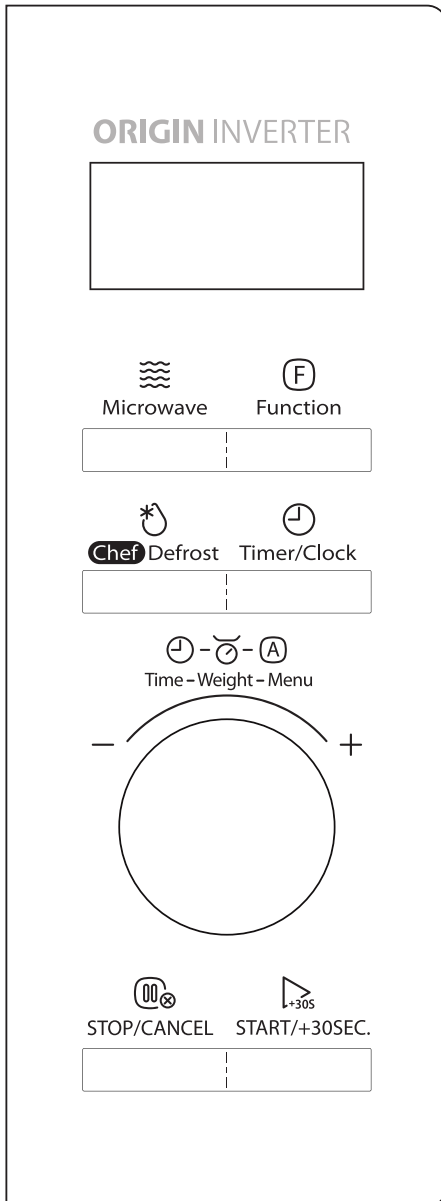

## 1. DE KLOK INSTELLEN

---

**a** Druk tweemaal op  Timer/Clock, "00:00" wordt weergegeven.



**b** Draai aan de knop om de uren in te stellen.

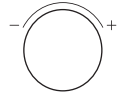

**c** Druk op  Timer/Clock of  START/+30SEC. om de uurcijfers te bevestigen.



of



**d** Draai aan de knop om de minuten in te stellen.

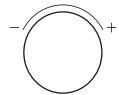

**e** Druk op  Timer/Clock of  START/+30SEC. om te bevestigen. De klok is ingesteld.



of



### OPMERKING

- De klok is een 24-uurs display. Als de klok niet is ingesteld, werkt deze niet als u hem inschakelt.
- Om de klok opnieuw in te stellen, herhaalt u stappen a tot e.

## 2. DE KOOKTIMER INSTELLEN

a Druk eenmaal op  Timer/Clock, "00:00" wordt weergegeven.



b Draai de knop om de gewenste kooktijd in te stellen.  
De maximale tijdswaarde is "95:00".

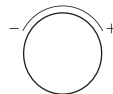

c Druk op  START/+30SEC. om te bevestigen. De timer begint af te tellen.



- De kookwekker werkt als een timer.
- Een ander programma kan niet worden ingesteld tijdens de kookwekker.

## 3. KOKEN MET DE MAGNETRON

Er zijn 10 beschikbare vermogensniveaus.

NIVEAU	VERMOGEN	DISPLAY
1	100%	P100
2	90%	P90
3	80%	P80
4	70%	P70
5	60%	P60
6	50%	P50
7	40%	P40
8	30%	P30
9	20%	P20
10	10%	P10

**a** Druk meerdere malen op  Microwave om het vermogensniveau te kiezen.



**a** of  
Druk eenmaal op  Microwave en draai aan de knop om het vermogensniveau te kiezen.  
Er zijn 10 beschikbare vermogensniveaus.



**b** Druk op  START/+30SEC. om het vermogensniveau te bevestigen.



**c** Draai aan de knop om de kooktijd in te stellen, de maximale tijd is "95:00".



**d** Druk op  START/+30SEC. om te beginnen met koken.



## 4. KOKEN MET DE GRILL

---

**a** Druk eenmaal op  Function, "G-1" wordt weergegeven.



**b** Druk op  START/+30SEC. om de modus te bevestigen.



**c** Draai aan de knop om de kooktijd in te stellen, de maximale tijd is "95:00".

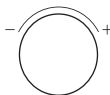

**d** Druk op  om te beginnen met koken.

 START/+30SEC.



• De zoemer klinkt om u eraan te herinneren het voedsel om te draaien tijdens het koken.  
Als u niets doet, zal de oven gewoon blijven werken.

## 5. KOKEN MET DE COMBINATIEFUNCTIE

**a** Druk herhaaldelijk op  om de gewenste kookmodus te kiezen. "C-1, C-2" zijn beschikbaar.  
of

 Function

Druk eenmaal op  en draai aan de knop om het vermogensniveau te kiezen.

 Function



**b** Druk op  om de modus te bevestigen.

 START/+30SEC.

**c** Draai aan de knop om de kooktijd in te stellen, de maximale tijd is "95:00".

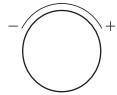

**d** Druk op  om te beginnen met koken.

 START/+30SEC.

### COMBINATIEKOOKSCHEMA

FUNCTIE	DISPLAY	MAGNETRONVERMOGEN	GRILLVERMOGEN
Combinatie 1	C-1	55%	45%
Combinatie 2	C-2	36%	64%

## 6. ONTDOOIEN OP TIJD

- a Druk eenmaal op , "dEF1" wordt weergegeven.



- b Draai aan de knop om de gewenste ontdooitijd in te stellen, de maximale tijdwaarde is "95:00".

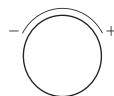

- c Druk op  om te beginnen met ontdooien.



- De zoemer klinkt twee keer om u eraan te herinneren het voedsel tijdens het ontdooien om te keren. Als u niets doet, zal de oven gewoon blijven werken.
- Het ontdooivermogen is P30 en kan niet worden aangepast.

## 7. ONTDOOIEN OP GEWICHT

- a Druk  herhaaldelijk op om het type voedsel te kiezen en vervolgens wordt "dEF2", "dEF3" of "dEF4" weergegeven.



- b Draai aan de knop om het gewicht van het voedsel in te stellen, deze moeten tussen "100 g-2000 g" ingesteld zijn.

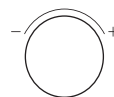

- c Druk op  om te beginnen met ontdooien.



LED-SCHERM	VOEDSEL	GEWICHT
dEF2	Vlees	100 g-2000 g
dEF3	Kip	100 g-2000 g
dEF4	Vis	100 g-2000 g



- De zoemer klinkt twee keer om u eraan te herinneren het voedsel tijdens het ontdooien om te keren. Als u niets doet, zal de oven gewoon blijven werken.

## 8. SNEL KOKEN

a Draai de knop naar links om een kooktijd in te stellen met 100% vermogen.

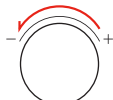

b Blijf aan de knop draaien om de kooktijd aan te passen, de maximale tijdswaarde is "95:00".



c Druk op  om te beginnen met koken.

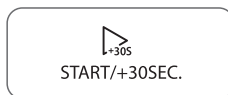

a Druk op  om voedsel met 100% vermogen gedurende 30 seconden te koken. Met elke druk op dezelfde toets wordt het 30 seconden verlengd en de maximale tijdswaarde is "95:00".



## 9. KOKEN MET MEERDERE FASEN

Voorbeeld: Als u het voedsel 5 minuten lang wilt ontdooien en vervolgens 7 minuten lang op 80% magnetronvermogen wilt koken.

a Druk eenmaal op , "dEF1" wordt weergegeven.



b Draai aan de knop om de gewenste ontdooitijd in te stellen op 5 minuten.



c Druk  herhaaldelijk totdat "P80" wordt weergegeven.



d Druk op  om het vermogensniveau te bevestigen.





e Draai de parameterknop om de kooktijd in te stellen op 7 minuten.

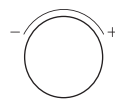

f Druk op  om te beginnen met koken.



**OPMERKING**

- Bij meergefasig koken kunnen twee kookfasen worden ingesteld.
- Als u de ontthooifunctie instelt, werkt deze automatisch in de eerste fase.
- Kookwekker, automatisch menu en snelkoken kunnen niet worden ingesteld als één van de meerdere fasen.

## 10. AUTOMATISCH MENU

---

a Draai in de stand-by-modus één keer aan de knop naar rechts en vervolgens wordt "A-1" weergegeven.

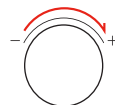

b Draai de parameterknop om het gewenste menu te kiezen. De 7 automatische menu's zijn beschikbaar.



c Druk op  om te bevestigen.



d Draai aan de knop om het gewicht van het voedsel in te stellen.

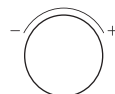

e Druk op  om te beginnen met koken.



## OVERZICHT VAN HET AUTOMATISCHE MENU

MENU	GEWICHT/ HOEVEELHEID	DISPLAY	VERMOGENSNIVEAU
A-1 Popcorn	50 g 100 g	50 g 100 g	P100
A-2 Aardappelen	1 (230 g) 2 (460 g) 3 (690 g)	1 2 3	P100
A-3 Pizza	200 g 400 g	200 g 400 g	P100
A-4 Bevroren groente	200 g 300 g 400 g	200 g 300 g 400 g	P100
A-5 Drank	1 kopje (120 ml) 2 kopjes (240 ml) 3 kopjes (360 ml)	1 2 3	P100
A-6 Mijn bord (dinerbord)	250 g 350 g 500 g	250 g 350 g 500 g	P100
A-7 Vlees (varkensvlees)	250 g 350 g 450 g	250 g 350 g 450 g	P80

## 11. KINDERSLOTFUNCTIE

---

U kunt deze functie gebruiken om te voorkomen dat kinderen per ongeluk de oven inschakelen.

- a** Om het slot te activeren:  
Houd in de stand-bymodus  gedurende drie seconden ingedrukt. Er klinkt een pieptoon en het vergrendelde pictogram wordt weergegeven.



- b** Om het slot te deactiveren:  
Houd in de vergrendelde toestand  drie seconden ingedrukt. Een pieptoon.



## 12. CONTROLEFUNCTIE

---

- a** Druk op  wanneer de oven aan het koken is, de huidige tijd verschijnt gedurende drie seconden op het display.



- b** Druk in de kookstand van de magnetron op  om te informeren naar het vermogensniveau. Het zal drie seconden worden weergegeven.



- c** Druk in de grill- en combinatietoestand op  om te informeren naar de kookmodus. Het zal drie seconden worden weergegeven.



# REINIGING EN ONDERHOUD

## REINIGEN

Bij goed onderhoud en reiniging zal uw apparaat er lang mooi blijven uitzien en correct blijven functioneren. Wij leggen u uit hoe u uw apparaat correct moet onderhouden en reinigen.



**WAARSCHUWING**

- Als het glas in de deur van apparaat krassen bevat, kan dit resulteren in een barst.  
Gebruik geen glasschraper, scherpe reinigingsmiddelen of schurende reinigingsmiddelen.
- Het oppervlak van het apparaat kan beschadigd raken als het niet goed wordt gereinigd. Microgolfenergie kan ontsnappen. Reinig het apparaat regelmatig en verwijder eventuele etensresten onmiddellijk.
- Dompel het apparaat niet onder in water en reinig het niet onder een waterstraal.

## Reinigingsmiddelen

Neem de gegevens in de tabel in acht om te voorkomen dat de verschillende oppervlakken worden beschadigd door het gebruik van verkeerde reinigingsmiddelen. Was nieuwe doeken grondig voor gebruik.

### Niet gebruiken:



Harde of schurende  
reinigingsmiddelen



Metalen of glazen  
schraper om de  
deurpanelen te reubugeb



Metalen of glazen  
schraper om de  
deurafdichting te reinigen



Harde schuursponsjes  
of sponzen



Reinigingsmiddelen met  
een hoog alcoholgehalte

## VOORKANT VAN HET APPARAAT

### Heet zeepwater:

Reinigen met een vaatdoek en droog vervolgens af met een zachte doek.  
Gebruik geen metalen of glazen schraper voor het reinigen.

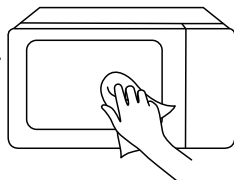

## VOORKANT APPARAAT MET ROESTVRIJ STAAL

---

### Heet zeepwater:

Reinigen met een vaatdoek en droog vervolgens af met een zachte doek.

Verwijder spatten en vlekken van kalkaanslag, vet, zetmeel en albumine onmiddellijk. Onder deze vlekken of spatten kan corrosie ontstaan. Gebruik geen glasreinigers of metalen of glazen schrapers voor het reinigen.

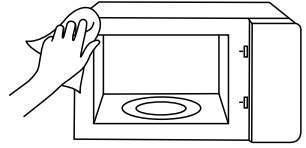

## KOOKCOMPARTIMENT VAN ROESTVRIJ STAAL

---

### Heet zeepwater of azijnoplossing:

Reinigen met een vaatdoek en droog vervolgens af met een zachte doek. Gebruik geen ovenspray of andere agressieve ovenreinigers of schurende materialen. Schuursponsjes, ruwe sponzen en pannenreinigers zijn ook ongeschikt. Deze middelen veroorzaken krassen op het oppervlak. Laat de binnenkant volledig drogen.

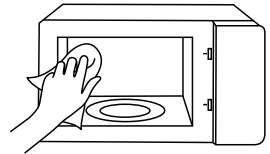

## UITSPARING AAM DE BINNENKANT

---

### Vochtige doek:

Voorkom dat er water in het apparaat loopt via de aandrijving van het draaiplateau. Droog de aandrijving van het draaiplateau met een doek.

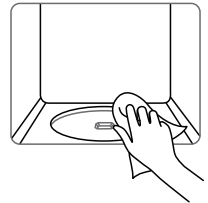

## DRAAIPLATEAU EN ROLRING

---

### Heet zeepwater:

Zorg bij het terugplaatsen van het draaiplateau in de uitsparing dat deze goed vastklikt.

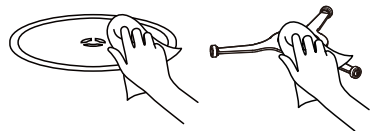

## DEURPANEEL

---

### Glasreiniger:

Reinigen met een vaatdoek. Gebruik geen glasschrapers.

# PROBLEEMOPLOSSING

Controleer uw probleem met behulp van de onderstaande tabel en probeer de oplossingen voor elk probleem.

Als de magnetron nog steeds niet goed werkt, neem dan contact op met het dichtstbijzijnde geautoriseerde servicecentrum.

PROBLEEM	MOGELIJKE OORZAAK	MOGELIJKE REMEDIE
Oven start niet	<ul style="list-style-type: none"> <li>a. Het netsnoer voor de oven is niet aangesloten.</li> <li>b. Deur is open.</li> <li>c. Verkeerde bediening is ingesteld.</li> </ul>	<ul style="list-style-type: none"> <li>a. Steek de stekker in het stopcontact.</li> <li>b. Sluit de deur en probeer het opnieuw.</li> <li>c. Instructies controleren</li> </ul>
Bogen of vonken	<ul style="list-style-type: none"> <li>a. Materialen die u in de magnetron moet vermijden zijn gebruikt.</li> <li>b. De oven wordt gebruikt wanneer deze leeg is.</li> <li>c. Gemorst voedsel blijft in de holte achter.</li> </ul>	<ul style="list-style-type: none"> <li>a. Gebruik alleen magnetronbestendig kookgerei.</li> <li>b. Gebruik het apparaat niet als de oven leeg is.</li> <li>c. Reinig de holte met een zachte vochtige doek.</li> </ul>
Ongelijk gekookt voedsel	<ul style="list-style-type: none"> <li>a. Materialen die u in de magnetron moet vermijden zijn gebruikt.</li> <li>b. Voedsel wordt niet volledig ontdooid.</li> <li>c. Kooktijd, vermogensniveau is niet geschikt.</li> <li>d. Het eten wordt niet omgedraaid of geroerd.</li> </ul>	<ul style="list-style-type: none"> <li>a. Gebruik alleen magnetronbestendig kookgerei.</li> <li>b. Ontdooi voedsel volledig.</li> <li>c. Gebruik de juiste kooktijd, vermogensniveau.</li> <li>d. Draai of roer het eten.</li> </ul>
Te gaar voedsel	Kooktijd, vermogensniveau is niet geschikt.	Gebruik de juiste kooktijd, vermogensniveau.
Ongekookt voedsel	<ul style="list-style-type: none"> <li>a. Materialen die u in de magnetron moet vermijden zijn gebruikt.</li> <li>b. Voedsel wordt niet volledig ontdooid.</li> <li>c. Ovenventilatiepoorten zijn beperkt.</li> <li>d. Kooktijd, vermogensniveau is niet geschikt.</li> </ul>	<ul style="list-style-type: none"> <li>a. Gebruik alleen magnetronbestendig kookgerei.</li> <li>b. Ontdooi voedsel volledig.</li> <li>c. Controleer of de ventilatiepoorten van de oven niet beperkt zijn.</li> <li>d. Gebruik de juiste kooktijd, vermogensniveau</li> </ul>
Onjuist ontdooiden	<ul style="list-style-type: none"> <li>a. Materialen die u in de magnetron moet vermijden zijn gebruikt.</li> <li>b. Kooktijd, vermogensniveau is niet geschikt.</li> <li>c. Het eten wordt niet omgedraaid of geroerd.</li> </ul>	<ul style="list-style-type: none"> <li>a. Gebruik alleen magnetronbestendig kookgerei.</li> <li>b. Gebruik de juiste kooktijd, vermogensniveau.</li> <li>c. Draai of roer het eten.</li> </ul>



Volgens de richtlijn betreffende afgedankte elektrische en elektronische apparatuur (AEEA) moet AEEA gescheiden worden ingezameld en verwerkt. Als u dit product in de toekomst moet afdanken, gooi dit product dan NIET bij het huishoudelijk afval. Stuur dit product naar AEEA-inzamelpunten, indien beschikbaar.



**#DetailsMatter**



# HASZNÁLATI ÚTMUTATÓ

## MIKROHULLÁMÚ SÜTŐ

MW3-AG25PFI(MG)

Használat előtt olvassa el ezt a használati útmutatót.

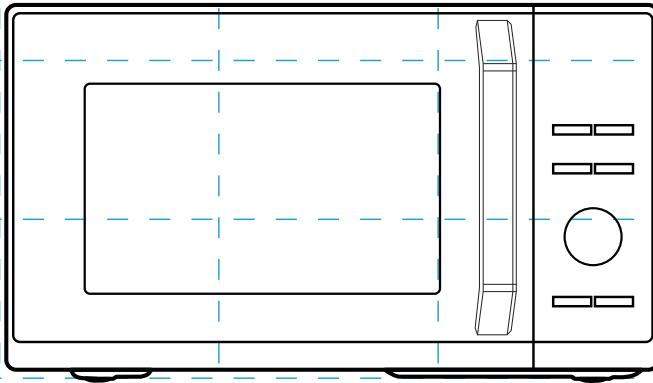

**TOSHIBA**

# TARTALOM

## TERMÉKBIZTONSÁG

Óvintézkedések a túlzott mértékű mikrohullámú energiának való kitettség elkerülése érdekében .....	HU-01
Műszaki jellemzők .....	HU-02
Fontos biztonsági utasítások .....	HU-03
A személyi sérülés veszélyének csökkentése – Földelés .....	HU-08
Tisztítás .....	HU-10
Edények .....	HU-11
Mikrohullámú sütőben használható anyagok .....	HU-12
Mikrohullámú sütőben nem használható anyagok .....	HU-14

## TERMÉK BEÁLLÍTÁSA

A sütő beállítása .....	HU-15
-------------------------	-------

## HASZNÁLATI ÚTMUTATÓ

Első használat előtt .....	HU-18
Működés .....	HU-19
Vezérlőpanel és funkciók .....	HU-19
1. Az óra beállítása .....	HU-20
2. A konyhai időzítő beállítása .....	HU-21
3. Mikrohullámú sütés .....	HU-21
4. Grillezés .....	HU-22
5. Kombinált főzés .....	HU-23
6. Kiolvasztás idő alapján .....	HU-24
7. Kiolvasztás súly szerint .....	HU-24
8. Gyorsfőzés .....	HU-25
9. Többfokozatú főzés .....	HU-25

10. Auto menü .....	HU-26
11. Zárfunkció gyermekek számára .....	HU-28
12. Lekérdező funkció .....	HU-28

## TISZTÍTÁS ÉS KARBANTARTÁS

Tisztítás .....	HU-29
Hibaelhárítás .....	HU-31



### MEGJEGYZÉS

A TERMÉK HASZNÁLATA ELŐTT OLVASSA EL,  
ÉRTSE MEG ÉS KÖVESSE EZEKET AZ  
UTASÍTÁSOKAT.  
MINDENKÉPPEN MENTSE EL EZT A  
KÖNYVLISTÁT KÉSŐBBI FELHASZNÁLÁSRA.

# TERMÉKBIZTONSÁG

## ÓVINTÉZKEDÉSEK ANNAK ELKERÜLÉSE ÉRDEKÉBEN, HOGY TÚL SOK MIKROHULLÁMÚ ENERGIA ÉRJEN MINKET

---

(a). Ne próbálja ezt a sütőt nyitott ajtóval üzemeltetni, mivel így káros mikrohullámú energia érheti. Fontos, hogy a biztonsági reteszeléseket ne törje el és ne rongálja meg.

(b). Ne helyezzen semmilyen tárgyat a sütő elülső felülete és az ajtó közé, és ne engedje, hogy szennyeződés vagy tisztítószer-maradék gyűljön össze a tömítőfelületeken.

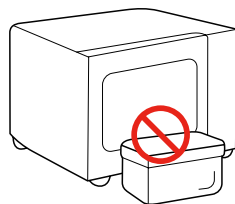

(c). **FIGYELEM:** Ha az ajtó vagy az ajtó-tömítések megsérültek, a sütőt addig tilos üzemeltetni, amíg azt hozzáértő személy meg nem javította.

### KIEGÉSZÍTÉS

---

Ha a készüléket nem tartják megfelelően tiszta állapotban, a felülete károsodhat, ami hatással lehet a készülék élettartamára, és veszélyes helyzethez vezethet.

## MŰSZAKI JELLEMZŐK

---

MODELL	MW3-AG25PFI(MG)
FESZÜLTSG/FREKVENCIA	230-240 V~ 50 Hz
MIKROHULLÁMÚ BEMENETI TELJESÍTMÉNY	1400 W
MIKROHULLÁMÚ KIMENETI TELJESÍTMÉNY	900 W
NÉVLEGES BEMENETI TELJESÍTMÉNY (GRILL)	1000-1100 W



### MEGJEGYZÉS

A kézikönyvben szereplő összes kép csak illusztráció; ezek kissé eltérhetnek a megvásárolt berendezéstől, kérjük, a tényleges termék alapján tájékozódjon.

# FONTOS BIZTONSÁGI UTASÍTÁSOK



## FIGYELEM

A tűz, áramütés, személyi sérülés vagy annak kockázata csökkentése végett, hogy a mikrohullámú sütő túl nagy energiája érjen minket, a készülék használata során tartsa be az alapvető óvintézkedéseket, beleértve a következőket:

 Olvassa el és kövesse specifikusan az alábbiakban leírtakat: **„ÓVINTÉZKEDÉSEK ANNAK ELKERÜLÉSE ÉRDEKÉBEN, HOGY TÚL SOK MIKROHULLÁMÚ ENERGIA ÉRJEN MINKET”**.

 Ezt a készüléket 8 évnél idősebb gyermekek, csökkent fizikai, érzékszervi vagy szellemi képességekkel rendelkező, illetve tapasztalattal és tudással nem rendelkező személyek csak felügyelet mellett vagy akkor használhatják, ha őket a készülék biztonságos használatára megtanították, és megértették az ezzel járó veszélyeket. Gyermekek ne játszanak a készülékkel. A tisztítást és a felhasználói karbantartást a gyermekek csak felügyelettel végezhetik.

 Tartsa a készüléket és annak vezetékét 8 évnél fiatalabb gyermekek számára hozzáférhetetlen helyen.

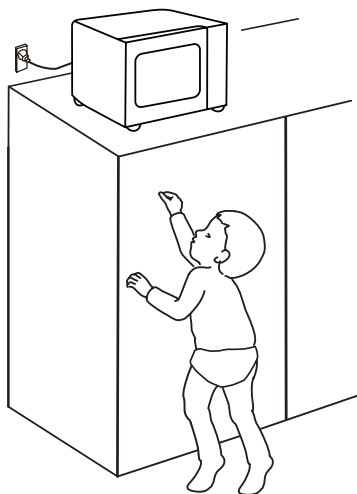



 Ha a tápvezeték sérült, a gyártóval, a hivatalos márkaszervizzel vagy megfelelően képzett

# FONTOS BIZTONSÁGI UTASÍTÁSOK

személlyel ki kell cseréltetni a veszély elkerülése érdekében.

 **FIGYELEM:** A lámpa cseréje előtt győződjön meg arról, hogy a készülék ki van kapcsolva, hogy kizárja az áramütés lehetőségét.

 **FIGYELEM:** Veszélyes, ha hozzáértő személyen kívül bárki más olyan szerviz- vagy javítási műveletet végez, amely annak a burkolatnak az eltávolításával jár, amely véd attól, hogy mikrohullámú energia érjen minket.

 **FIGYELEM:** Folyadékot és egyéb élelmiszereket nem szabad lezárt tárolóedényben melegíteni, mivel azok robbanásveszélyesek.

 Ha műanyag vagy papír tárolóedényekben melegít ételeket, tartsa szemmel a sütőt, mivel fennáll annak a lehetősége, hogy azok meggyulladnak.



 Csak olyan edényeket használjon, amelyek alkalmasak mikrohullámú sütőben való használatra.

 Ha a készülék füstöt bocsát ki, kapcsolja ki, vagy húzza ki a konnektorból, és a lángok elfojtása érdekében tartsa zárva az ajtaját.

 Az italok mikrohullámú melegítése késleltetett robbanásszerű forrással járhat, ezért az edény kezelésekor járjon el körültekintően.

 A cumisüvegek és bébiételt tartalmazó üvegek tartalmát az égési sérülések elkerülése érdekében meg kell keverni vagy össze kell

# FONTOS BIZTONSÁGI UTASÍTÁSOK

rázni, és a hőmérsékletüket ellenőrizni kell a fogyasztást megelőzően.

 A sütőt rendszeresen tisztítani kell, és az esetleges ételmaradékokat el kell távolítani. Kérjük, tartsa tisztán a hullámvezető területét. Puha, nedves ruhával tisztítsa meg, ha ételmaradék van a hullámvezető területén vagy az üregben. Az ételmaradékok tisztításának elmulasztása ártalmatlan szikrázást vagy némi füstöt okozhat a mikrohullámú sütőben üregében, továbbá az üreg elszíneződése is bekövetkezhet.

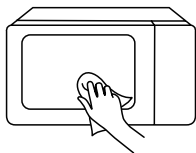

 A sütő tisztán tartásának elmulasztása a felület romlásához vezethet, ami hátrányosan befolyásolhatja a készülék élettartamát, és esetleges

veszélyes helyzetet is eredményezhet.

 Csak az ehhez a készülékhez ajánlott ételhőmérőt használjon. (Olyan készülékek esetén, amelyek rendelkeznek hőmérővel.)

 A mikrohullámú sütőt nyitott dekoratív ajtóval kell működtetni. (A dekoratív ajtóval ellátott sütők esetében.)

 Ez a készülék háztartási és hasonló alkalmazásokban történő használati célokra szolgál, mint például:

1. üzletek, irodák és egyéb munkakörnyezetek dolgozói konyhai helyiségei;
2. szállodák, motelek és más lakóhelyjellegű környezetek vendégeit kiszolgáló;
3. parasztházak;
4. szállást reggelivel kínáló környezetek.



# FONTOS BIZTONSÁGI UTASÍTÁSOK

 A mikrohullámú sütő ételek és italok melegítésére szolgál. Az ételek vagy ruhák szárítása, és a melegítőpárnák, papucskok, szivacsok, nedves ruhák és hasonlók melegítése sérülés- vagy tűzveszélyt okozhat.

---

 A készülék hátsó felületének a fal felé kell néznie.

---

 A készülék működése közben a megérinthető felületek hőmérséklete magas lehet.

---

 **FIGYELEM:** Ha a készülék kombinált üzemmódban működik, a hőmérséklete miatt a gyermekek csak felnőtt felügyelete mellett használhatják a sütőt.

 A készüléket szabadon álló használatra tervezték.

---

 Tojásokat héjukban és egész keményre főtt tojásokat nem szabad mikrohullámú sütőben melegíteni, mivel még akkor is felrobbanhatnak, amikor a mikrohullámú melegítés már befejeződött.

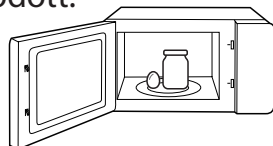

 The a mikrohullámú sütő nem helyezhető szekrénybe, kivéve, ha tesztelték a szekrényben történő üzemeltetést.

---

 Az ételek és italok fém tárolóedényei mikrohullámú sütés közben nem használhatók.

---

 A készüléket nem szabad gőztisztítóval tisztítani.

# FONTOS BIZTONSÁGI UTASÍTÁSOK

 A készülékek nem használhatók külső időzítővel vagy külön távirányító rendszerrel.

 A készüléket a túlmelegedés elkerülése érdekében nem szabad dekoratív ajtó mögé telepíteni.  
(A dekoratív ajtóval ellátott készülékekre nem vonatkozik).

OLVASSA EL FIGYELMESEN, ÉS ŐRIZZE  
MEG KÉSŐBBI HASZNÁLATRA

# A SZEMÉLYI SÉRÜLÉS VESZÉLYÉNEK CSÖKKENTÉSE – FÖLDELÉS

Ezt a készüléket földelni kell. Elektromos rövidzárlat esetén a földelés csökkenti az áramütés veszélyét, mivel levezető vezetékét biztosít az elektromos áram számára.

Ezt a készüléket egy földelő vezetékes, földelődugóval rendelkező kábellel látták el. A dugót megfelelően felszerelt és földelt konnektorba kell dugni.

**FIGYELEM** - A földelés helytelen használata áramütés veszélyével járhat. Forduljon szakképzett villanszerelőhöz vagy szerelőhöz, ha a földelési utasításokat nem érti teljesen, vagy ha kétségei vannak a készülék megfelelő földelésével kapcsolatban. Ha hosszabbítót kell használni, akkor csak háromvezetékes hosszabbítót használjon.



Áramütés veszélye:

A belső alkatrészek némelyikének megérintése súlyos személyi sérülést vagy halált okozhat. Ne szerelje szét ezt a készüléket.

# A SZEMÉLYI SÉRÜLÉS VESZÉLYÉNEK CSÖKKENTÉSE – FÖLDELÉS

Áramütés veszélye:

A földelés helytelen használata áramütést okozhat. Addig ne dugja be a készüléket a konnektorba, amíg megfelelően be nem szerelték és nem földelték.

1. Azért rövid tápkábelt mellékelünk, hogy ezzel is csökkentsük a hosszabb vezetékbe való belegabalyodás vagy a benne történő megbotlás kockázatát.
2. Ha hosszú vezetéket vagy hosszabbítót használ:
  - (1). A kábelkészlet vagy hosszabbítókábel névleges elektromos jellemzőinek meg kell egyeznie a készülék névleges elektromos jellemzőivel, vagy meg kell haladnia azokat.
  - (2). A hosszabbítókábelnek földelt, háromeres vezetéknek kell lennie.
  - (3). A hosszabb kábelt úgy kell elvezetni, hogy az ne fusson a pult vagy az asztallap fölött úgy, hogy a gyermekek meghúzhassák vagy valaki megbotothasson benne.



**FIGYELEM**

# TISZTÍTÁS

Feltétlenül húzza ki a készüléket a hálózathoz.

1. Használat után enyhén nedves ruhával tisztítsa meg a sütő sütőterét.
2. A tartozékokat a szokásos módon, szappanos vízben tisztítsa meg.
3. Az ajtókeretet és a tömítést, valamint az azokkal szomszédos részeket óvatosan, nedves ruhával kell megtisztítani, ha szennyezettek.
4. Ne használjon durva súrolószereket vagy éles fémkaparókat a sütőajtó üvegének tisztításához, mivel ezek megkarcolhatják a felületet, ami az üveg töréséhez vezethet.
5. Tisztítási tipp---A sütőtér azon falainak könnyebb tisztításához, amelyekkel a főtt ételek érintkezhetnek: Tegyen egy fél citromot egy tálba, adjon hozzá 300 ml vizet, és üzemeltesse a sütőt 100%-os mikrohullámú teljesítményen 10 percig. Törölje tisztára a sütőt egy puha, száraz ruhával.

# EDÉNYEK



VIGYÁZAT

Személyi sérülés veszélye:

Veszélyes, ha hozzáértő személyen kívül bárki más olyan szerviz- vagy javítási műveletet végez, amely annak a burkolatnak az eltávolításával jár, amely véd attól, hogy mikrohullámú energia érjen minket.

Olvassa el az utasításokat a „**Mikrohullámú sütőben használható anyagok**” vagy „**Mikrohullámú sütőben nem használható anyagok**” részekben.

Előfordulhat, hogy bizonyos nem fémből készült edények nem biztonságosak a mikrohullámú sütéshez. Ha kétségei vannak, az alábbi eljárás szerint tesztelheti a kérdéses edényt.

## Edényteszt:

1. Töltsön meg egy mikrohullámú sütésre alkalmas edényt 1 csésze hideg vízzel (250 ml), és helyezze a készülékbe.
2. Főzze maximális teljesítményen 1 percig.
3. Óvatosan tapintsa meg az edényt. Ha az üres edény meleg, ne használja mikrohullámú sütéshez.
4. Ne lépje túl az 1 perces főzési időt.

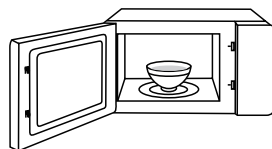

MEGJEGYZÉS

TARTSA TISZTÁN AZ  
ÜREGET ÉS A  
HULLÁMVEZETŐ TERÜLETET

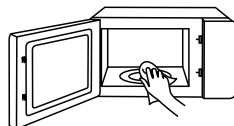

# MIKROHULLÁMÚ SÜTŐBEN HASZNÁLHATÓ ANYAGOK

## EDÉNYEK

## MEGJEGYZÉSEK



Barnító edény

Kövesse a gyártó utasításait.

A barnító edény aljának legalább 3/16 hüvelyk (5 mm) magasságban kell lennie a forgótányér felett. A helytelen használat a forgótányér törését okozhatja.



Étkészlet

Csak ami mikrohullámú sütőben használható.

Kövesse a gyártó utasításait. Ne használjon repedt vagy törött edényeket.



Üvegpoharak

Mindig távolítsa el a fedelet. Csak addig melegítse az ételt, amíg éppen hogy csak meleg nem lesz. A legtöbb üvegedény nem hőálló, és eltörhet.



Üvegedények

Csak hőálló sütőüvegeket használjon. Győződjön meg arról, hogy nincs rajta fém díszítés. Ne használjon repedt vagy törött edényeket.



Sütőben használható  
főzőtasakok

Kövesse a gyártó utasításait. Ne zárja le fémkötegelővel. Alakítson ki réseket, hogy a gőz távozni tudjon.



Papírtányérok és poharak

Csak rövid távú főzéshez/melegítéshez használja azokat. Ne hagyja felügyelet nélkül a süttőt főzés közben.



Papírtörölközők

Használhatóak az ételek letakarására újramelegítésnél és a zsír felszívásához. Csak felügyelet mellett, rövid ideig tartó főzéshez használja azokat.

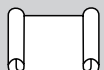

Pergamenpapír

Használhatja fedőnek a szétfröccsenés megakadályozására, vagy gőzöléskor csomagolópapírként.



# MIKROHULLÁMÚ SÜTŐBEN HASZNÁLHATÓ ANYAGOK

## EDÉNYEK

## MEGJEGYZÉSEK



Műanyag

Csak ami mikrohullámú sütőben használható. Kövesse a gyártó utasításait. „Mikrohullámú sütőben biztonságos” felirattal kell rendelkeznie. Egyes műanyag edények megpuhulnak, ahogy a bennük lévő étel felforrósodik. A „főzőtasakokat” és a szorosan lezárt műanyag zacskókat a csomagoláson szereplő utasítás szerint fel kell hasítani, ki kell lyukasztani vagy légteleníteni kell.



Műanyag fólia

Csak ami mikrohullámú sütőben használható. Használhatja az ételek befedésére főzés közben, hogy megőrizze a nedvességtartalmukat. Ne engedje, hogy a műanyag fólia hozzáérintse az ételhez.

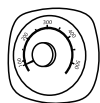

Hőmérők

Csak ami mikrohullámú sütőben használható (hús- és édesség hőmérők).



Viaszos papír

Használhatja fedőként a fröccsenés megakadályozására és a nedvességtartalom megőrzésére.





# MIKROHULLÁMÚ SÜTŐBEN NEM HASZNÁLHATÓ ANYAGOK

## EDÉNYEK

## MEGJEGYZÉSEK

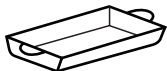

Alumíniumtálca

Ívkepződést okozhat. Helyezze át az ételt mikrohullámú sütésre alkalmas edénybe.



Fém fogantyúval ellátott élelmiszerdoboz

Ívkepződést okozhat. Helyezze át az ételt mikrohullámú sütésre alkalmas edénybe.



Fémedények vagy fém díszítésű edények

A fém elzárja az ételt a mikrohullámú energiától. A fém díszítés ívesedéshez vezethet.



Fém csavarkötők

Ívet okozhatnak, és tűz keletkezhet a sütőben.

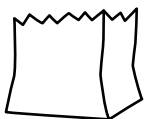

Papírtasakok

Tüzet okozhat a sütőben.



Műanyag hab

A műanyag hab megolvadhat vagy beszennyezheti a benne lévő folyadékot, ha magas hőmérsékletnek van kitéve.



Fa

A fa kiszárad, ha mikrohullámú sütőben használják, és megrepedhet vagy szétválhat.



# TERMÉK BEÁLLÍTÁSA

## A SÜTŐ BEÁLLÍTÁSA

### A MIKROHULLÁMÚ SÜTŐ ALKATRÉSZEINEK ÉS TARTOZÉKAINAK NEVEI

Vegye ki a sütőt és minden anyagot a dobozból és a sütőtérből.



Forgótányér-gyűrű szerelvény

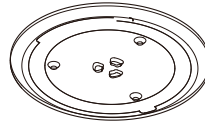

Üvegtálca

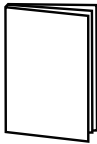

Használati útmutató

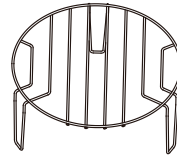

Grillrács (mikrohullámú sütő funkcióban nem használható, és az üvegtálcára kell helyezni)

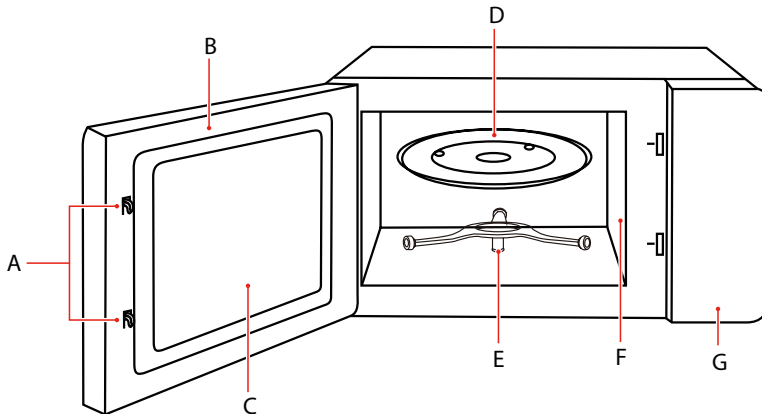

- A) Biztonsági reteszelőrendszer
- B) Ajtószerelvény
- C) Megfigyelőablak
- D) Üvegtálca

- E) Forgótányér-gyűrű szerelvény
- F) Hullámvezető burkolat
- G) Vezérlőpanel



Ha a készülék különbözik a kézikönyvben közölt ábráktól, a készülék a mérvadó.

# A SÜTŐ BEÁLLÍTÁSA

## A FORGÓTÁNYÉR BESZERELÉSE

Tisztítsa meg a főzőteret és tegye a forgótányért a helyére.

Új telepítés esetén győződjön meg arról, hogy minden csomagoló- és szállítási rögzítőszalagot eltávolított a forgótányér tengelyéről.

Mielőtt először használná a készüléket ételkészítésre, a forgótányért megfelelően a helyére kell tenni. Tisztítsa meg a főzőteret és a tartozékokat. A tisztítási szakasznál is tájékozódhat.

A forgótányér behelyezése:

1. Helyezze a forgótányér-gyűrű szerelvényt ② a főzőtér bemélyedésébe.
2. Helyezze az üvegtálcát ① a forgótányér-gyűrű szerelvényre ②.

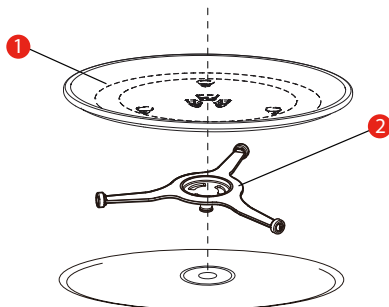

- 1) Üvegtálca  
2) Forgótányér-gyűrű szerelvény

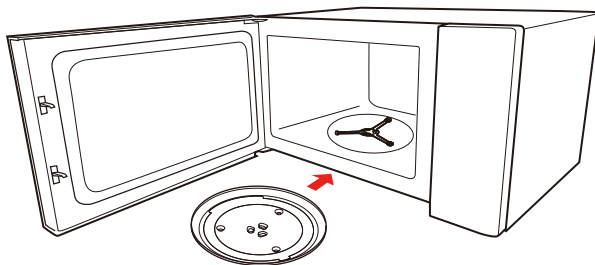

**MEGJEGYZÉS**

- Soha ne használja a készüléket forgótányér nélkül. Ellenőrizze, hogy a forgótányér megfelelően a helyén van-e. A forgótányér az óramutató járásával megegyező vagy ellentétes irányban foroghat.
- Soha ne helyezze be az üvegtálcát fejjel lefelé. Az üvegtálcát mozgását soha nem szabad akadályozni.
- Az üvegtálcát és a forgótányér-gyűrű szerelvényt is mindig használni kell a főzés során.
- Minden ételt és ételtároló edényt mindig az üvegtálcára kell helyezni a főzéshez.
- Soha ne akadályozza a forgótányér mozgását.
- Ha az üvegtálca vagy a forgótányér-gyűrű szerelvény megreped vagy eltörik, forduljon a legközelebbi hivatalos szervizközponthoz.

## ELHELYEZÉS A PULTON

Távolítson el minden csomagolóanyagot és tartozékot. Ellenőrizze, hogy a készüléken nincsenek-e sérülések, például horpadások vagy törött ajtó. Ha a készülék sérült, ne telepítse.

Kamra: Távolítson el minden védőfóliát a mikrohullámú sütő kamrájának felületéről. Ne távolítsa el a világosbarna hullámvezető takarót a sütőtér belsejéből, amely a magnetront védi.

## FELSZERELÉS

1. Válasszon egy vízszintes felületet, ahol elég hely áll rendelkezésre a légbeszívó és/vagy légkifúvó nyílások számára.

a. A minimális telepítési magasság 85 cm.

b. A készülék hátsó felületét a falhoz kell helyezni. Hagyjon legalább 30 cm távolságot a sütő felett. Legalább 20 cm távolságnak kell lennie a sütő és a szomszédos falak között.

c. Ne távolítsa el a lábakat a készülék aljáról.

d. A légbemeneti és/vagy légkimeneti nyílások eltakarása károsíthatja a készüléket.

e. A sütőt helyezze a rádió- és tévékészülékektől minél távolabbra. A mikrohullámú sütő működés közben zavarhatja a tévé- és rádióvételt.

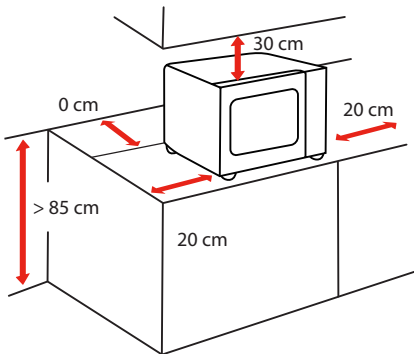

OLDAL	TÁVOLSÁG CM
Felső	30 cm
Bal	20 cm
Jobb	20 cm
Hátul	0 cm
Elöl	Megnyitás

2. Csatlakoztassa a sütőt egy szabványos konnektorhoz. Ellenőrizze, hogy a hálózati feszültség és frekvencia megegyezik-e a készülék típus tábláján feltüntetett feszültséggel és frekvenciával.



**MEGJEGYZÉS**

- Ne helyezze a sütőt tűzhely vagy más hőtermelő készülék fölé. Ha hőforrás fölé telepíti, azzal károsíthatja a készüléket, és elveszítheti a jótállást.

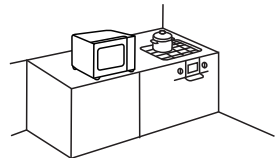

A hozzáférhető felület működés közben forró lehet.

# HASZNÁLATI ÚTMUTATÓ

## ELSŐ HASZNÁLAT ELŐTT

**Normális jelenség, ha a készülék első használatba vételekor kellemetlen szagok keletkezhetnek.**

Ez a szakasz ismerteti, hogy mit kell tennie, mielőtt először használná a mikrohullámú készüléket ételek készítésére. Előzetesen olvassa el a „**TERMÉKBIZTONSÁG**” című részt.

Mielőtt használhatná az új készüléket, a forgótányért megfelelően a helyére kell helyeznie. Tisztítsa meg a főzőteret és a tartozékokat.



### MEGJEGYZÉS

- Soha ne használja a készüléket forgótányér nélkül.
- Ellenőrizze, hogy a forgótányér megfelelően a helyén van-e. A forgótányér az óramutató járásával megegyező vagy ellentétes irányban foroghat.

# MŰKÖDÉS

## VEZÉRLŐPANEL ÉS FUNKCIÓK

---

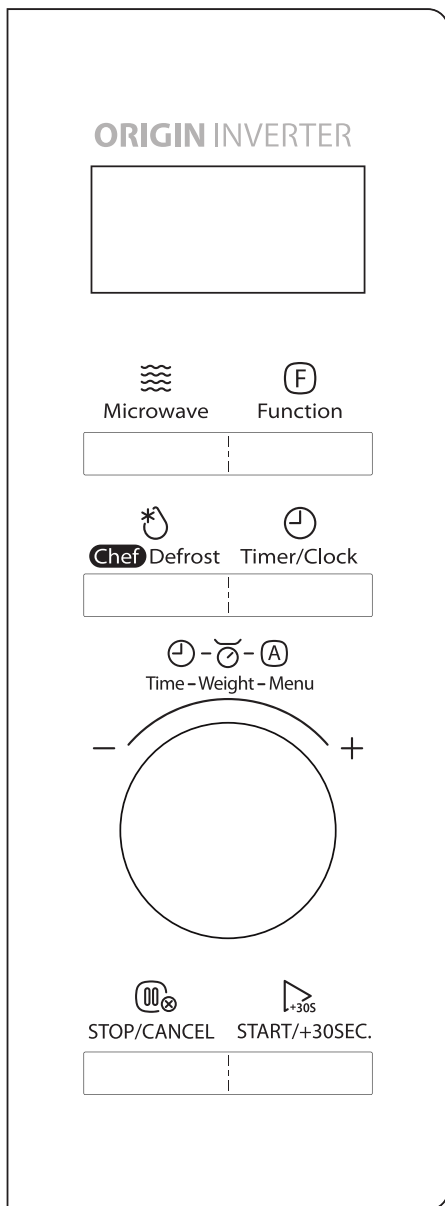



# 1. AZ ÓRA BEÁLLÍTÁSA

**a** Nyomja meg kétszer a  Timer/Clock gombot,  
„00:00” fog megjelenni.



**b** Forgassa a gombot az órák számainak beállításához.



**c** Nyomja meg a(z)  Timer/Clock vagy  
 START/+30SEC. gombot az óraadatok  
megerősítéséhez.





vagy

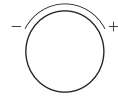

**d** Forgassa a gombot a percek számainak beállításához.



**e** Nyomja meg a  Timer/Clock vagy a  
 START/+30SEC. gombot a megerősítéshez.  
Az óra be van állítva.



vagy



## MEGJEGYZÉS

- Az óra 24 órás kijelzővel rendelkezik. Ha az óra nincs beállítva, akkor nem fog működni bekapcsoláskor.
- Az óra visszaállításához ismételje meg az a-e lépéseket.

## 2. A KONYHAI IDŐZÍTŐ BEÁLLÍTÁSA

- a** Nyomja meg a  gombot egyszer, a „00:00” felirat fog megjelenni.



- b** Forgassa a gombot a kívánt időtartam beállításához. A maximális érték "95:00".

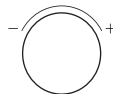

- c** Nyomja meg a  gombot a megerősítéshez. Az időzítő elkezd a visszazámlálást.



- A konyhai időzítő egy időzítő.
- A konyhai időzítő alatt semmilyen más program nem állítható be.

## 3. MIKROHULLÁMÚ SÜTÉS

10 teljesítményszint áll rendelkezésre.

SZINT	TELJESÍTMÉNY	KIJELZŐ
1	100%	P100
2	90%	P90
3	80%	P80
4	70%	P70
5	60%	P60
6	50%	P50
7	40%	P40
8	30%	P30
9	20%	P20
10	10%	P10



**a** Nyomja meg a  Microwave gombot többszörösen a teljesítményszint kiválasztásához.



**a** Nyomja meg a  Microwave gombot egyszer, majd forgassa el a gombot a teljesítményszint beállításához.  
10 teljesítményszint áll rendelkezésre.



**b** Nyomja meg a  START/+30SEC. gombot a teljesítményszint megerősítéséhez.



**c** Forgassa el a gombot a sütési idő beállításához, a maximális időérték „95:00”.

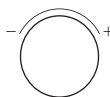

**d** Nyomja meg a  START/+30SEC. gombot a főzés megkezdéséhez.



## 4. GRILLEZÉS

---

**a** Nyomja meg egyszer a  Function gombot, ekkor megjelenik a „G-1” kijelzés.



**b** Nyomja meg a  START/+30SEC. gombot az üzemmód megerősítéséhez.



**c** Forgassa el a gombot a sütési idő beállításához, a maximális időérték „95:00”.

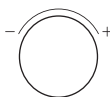

d Nyomja meg a  gombot a főzés megkezdéséhez.

  
START/+30SEC.



• A hangjelzés emlékeztetni fogja Önt, hogy a sütés során fordítsa meg az ételt.  
Ha nem csinál semmit, akkor a sütő folytatja a működését.

## 5. KOMBINÁLT FŐZÉS

a Nyomja meg többszörösen a  gombot a kívánt sütési mód kiválasztásához. „C-1, C-2” áll rendelkezésre. **vagy**

  
Function

c Nyomja meg a  gombot egyszer, majd forgassa el a gombot a sütési mód kiválasztásához.

  
Function



b Nyomja meg a  gombot az üzemmód megerősítéséhez.

  
START/+30SEC.

c Forgassa el a gombot a sütési idő beállításához, a maximális időérték „95:00”.

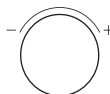

d Nyomja meg a  gombot a főzés megkezdéséhez.

  
START/+30SEC.

### KOMBINÁLT FŐZÉSI TÁBLÁZAT

FUNKCIÓK	KIJELZŐ	MIKROHULLÁMÚ TELJESÍTMÉNY	GRILL TELJESÍTMÉNY
Kombi. 1	C-1	55%	45%
Kombi. 2	C-2	36%	64%

## 6. KIOLVASZTÁS IDŐ ALAPJÁN

a Nyomja meg egyszer a  gombot, ekkor megjelenik a „dEF1” kijelzés.



b Forgassa el a gombot a kívánt kiolvasztási idő beállításához, a maximális időérték „95:00”.

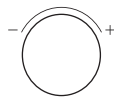

c Nyomja meg a  gombot a leolvasztás megkezdéséhez.



- A hangjelzés emlékeztetni fogja Önt, hogy a kiolvasztás során fordítsa meg az ételt. Ha nem csinál semmit, akkor a sütő folytatja a működését.
- A kiolvasztási teljesítmény P30, és nem változtatható.

## 7. KIOLVASZTÁS SÚLY SZERINT

a Nyomja meg a  gombot többszörösen az étel típusának kiválasztásához, majd megjelenik a „dEF2”, „dEF3” vagy „dEF4” felirat.



b Forgassa el a gombot az étel súlyának beállításához. „100g-2000g” tartományon belül kell lennie.

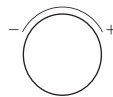

c Nyomja meg a  gombot a leolvasztás megkezdéséhez.



LED KIJELZŐ	ÉTEL	TÖMEG
dEF2	Hús	100 g-2000 g
dEF3	Csirke	100 g-2000 g
dEF4	Hal	100 g-2000 g



- A hangjelzés emlékeztetni fogja Önt, hogy a kiolvasztás során fordítsa meg az ételt. Ha nem csinál semmit, akkor a sütő folytatja a működését.

## 8. GYORSFŐZÉS

- a** Forgassa a gombot balra a főzési idő beállításához 100%-os teljesítményen.

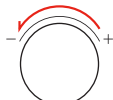

- b** Forgassa tovább a gombot a sütési idő beállításához, a maximális időérték „95:00”.



- c** Nyomja meg a  gombot a főzés megkezdéséhez.



- a** Nyomja meg a  gombot az étel 100%-os teljesítményszinten való 30 másodpercig történő főzéséhez. Ugyanannak a billentyűnek minden egyes megnyomása 30 másodpercet hosszabbít, és a maximális időérték „95:00”.



## 9. TÖBBFOKOZATÚ FŐZÉS

Példa: Olvassa ki az ételt 5 percig, majd főzze 80%-os mikrohullámú teljesítménnyel 7 percig.

- a** Nyomja meg a  gombot egyszer, a „dEF1” fog megjelenni.



- b** Forgassa a gombot az 5 perces kiolvasztási időtartam beállításához.



- c** Nyomja meg a  gombot többször, amíg a „P80” meg nem jelenik.



- d** Nyomja meg a  gombot a teljesítményszint megerősítéséhez.



e Forgassa a gombot a 7 perces főzési időtartam beállításához.

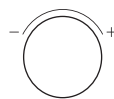

f Nyomja meg a  gombot a főzés megkezdéséhez.



**MEGJEGYZÉS**

- Két főzési fokozat állítható be a többfokozatú főzésben.
- Ha beállítja a leolvasztás funkciót, az automatikusan az első szakaszban működik.
- A konyhai időzítő, az auto menü és a gyorsfőzés nem állítható be többszakaszos műveletek egyikeként.

## 10. AUTO MENÜ

a Készletléti módban forgassa el a gombot egyszer jobbra, amíg az „A-1” meg nem jelenik.

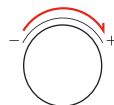

b Forgassa el a gombot többszörösen a kívánt menü kiválasztásához. 7 automatikus menü elérhető.



c Nyomja meg a  gombot a megerősítéshez.



d Forgassa a gombot az étel tömegének beállításához.



e Nyomja meg a  gombot a főzés megkezdéséhez.



## AUTO MENÜ TÁBLÁZAT

MENÜ	TÖMEG/MENNYISÉG	KIJELZŐ	TELJESÍTMÉNYSZINT
A-1 Pattogatott kukorica	50 g 100 g	50 g 100 g	P100
A-2 Burgonya	1 (230 g) 2 (460 g) 3 (690 g)	1 2 3	P100
A-3 Pizza	200 g 400 g	200 g 400 g	P100
A-4 Fagyasztott zöldség	200 g 300 g 400 g	200 g 300 g 400 g	P100
A-5 Ital	1 csésze (120 ml) 2 csésze (240 ml) 3 csésze (360 ml)	1 2 3	P100
A-6 Saját tányér (Vacsoratányér)	250 g 350 g 500 g	250 g 350 g 500 g	P100
A-7 Hús (sertés)	250 g 350 g 450 g	250 g 350 g 450 g	P80

## 11. ZÁRFUNKCIÓ GYERMEKEK SZÁMÁRA

---

Ezzel a funkcióval megakadályozhatja, hogy a gyerekek véletlenül bekapcsolják a sütőt.

- a** A zár bekapcsolásához:  
Készletléti üzemmódban nyomja meg és tartsa lenyomva a  gombot három másodpercig. Egy hangjelzés hallatszik, és megjelenik a lakat jelzés.



- b** A zár kikapcsolásához:  
Lezárt állapotban nyomja meg és tartsa lenyomva a  gombot három másodpercig. Egy hangjelzés hallatszik.



## 12. LEKÉRDEZŐ FUNKCIÓ

---

- a** Amikor a sütő süt, nyomja meg a  Timer/Clock gombot, az aktuális idő három másodpercre megjelenik a kijelzőn.



- b** Mikrohullámú főzési állapotban nyomja meg a  Microwave gombot a teljesítményszint lekérdezéséhez. Három másodpercig jelenik meg a kijelzőn.



- c** Grillezési és kombinált főzési állapotban nyomja meg a  Function gombot, hogy lekérdezze a sütési módot. Három másodpercig jelenik meg a kijelzőn.



# TISZTÍTÁS ÉS KARBANTARTÁS

## TISZTÍTÁS

Gondoskodással és tisztítással a készülék megőrzi megjelenését és hosszú ideig teljes mértékben működőképes marad. Itt ismertetjük, hogyan kell helyesen ápolni és tisztítani a készüléket.



**FIGYELEM**

- A készülék ajtajának megkarcolt üvege repedéssé alakulhat. Ne használjon üvegkaparót, éles vagy csiszoló hatású tisztítószeret vagy tisztítószereket.
- A készülék felülete károsodhat, ha nem megfelelően tisztítják. A készülékből mikrohullámú energia szabadulhat ki. Rendszeresen tisztítsa meg a készüléket, és azonnal távolítsa el az ételmaradékokat.
- Ne merítse a készüléket vízbe, és ne tisztítsa vízsugár alatt.

### Tisztítószer

Annak érdekében, hogy a különböző felületek ne sérüljenek meg a nem megfelelő tisztítószer használata miatt, vegye figyelembe a táblázatban szereplő információkat. Az új törülközőket használat előtt alaposan mossa ki.

**NE használjon:**



Kemény vagy súroló hatású tisztítószeret



Fém vagy üvegkaparót az ajtópanelek tisztításához



Fém vagy üvegkaparót az ajtótomítás tisztításához



Kemény dörzspárnákat vagy szivacsokat



Magas alkoholtartalmú tisztítószeret

### KÉSZÜLÉK ELŐOLDALA

**Forró szappanos víz:**

Tisztítsa meg egy mosogatóronggyal, majd szárítsa meg egy puha ruhával.

Ne használjon fém- vagy üvegkaparót a tisztításhoz.

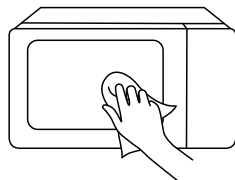



## KÉSZÜLÉK ELEJE ROZSDAMENTES ACÉLLAL

---

### Forró szappanos víz:

Tisztítsa meg egy mosogatóronggyal, majd szárítsa meg egy puha ruhával.

Azonnal távolítsa el a vízkő-, zsír-, keményítő- és albuminfoltokat.

Ezek alatt a foltok vagy a fröccsenések alatt korrózió alakulhat ki.

Ne használjon üvegtisztítót, fém- vagy üvegkaparót a tisztításhoz.

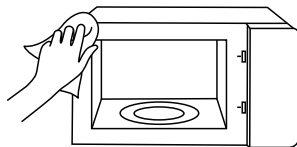

## ROZSDAMENTES ACÉLBŐL KÉSZÜLT SÜTŐTÉR

---

### Forró szappanos víz vagy ecetes oldat:

Tisztítsa meg egy mosogatóronggyal, majd szárítsa meg egy puha ruhával. Ne használjon sütóspray-t vagy más agresszív sütőtisztítót vagy dörzshatású anyagokat. A súrolószivacsok, durva szivacsok és edénytisztítók szintén alkalmatlanok. Ezek megkarcolhatják a felületet. Hagyja a belső felületeket teljesen megszáradni.

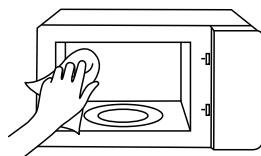

## A FŐZŐTÉR BEN LÉVŐ MÉLYEDÉS

---

### Nedves ruha:

Ügyeljen rá, hogy a forgótányér hajtásán keresztül ne jusson víz a készülékbe. A forgótányér hajtását szárítsa meg törlőkendővel.

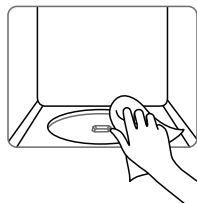

## FORGÓTÁNYÉR ÉS HENGERES GYŰRŰ

---

### Forró szappanos víz:

Amikor a forgótányért visszahelyezi a mélyedésbe, annak megfelelően illeszkednie kell a helyére.

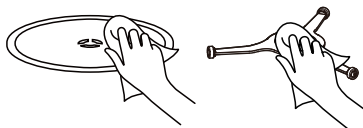

## AJTÓPANELEK

---

### Üvegtisztító:

Tisztítsa meg mosogatókendővel. Ne használjon üvegkaparót.

# HIBAEELHÁRÍTÁS

Ellenőrizze a problémát az alábbi táblázat segítségével, és próbálja ki az egyes problémák megoldását. Ha a mikrohullámú sütő továbbra sem működik megfelelően, forduljon a legközelebbi hivatalos szervizhez.

PROBLÉMA	LEHETSÉGES OK	LEHETSÉGES MEGOLDÁS
A sütő nem indul el	a. A sütő elektromos kábele nincs csatlakoztatva. b. Az ajtó nyitva van. c. Rossz művelet van beállítva.	a. Dugja be a konnektorba. b. Csukja be az ajtót, és próbálkozzon újra. c. Ellenőrizze az utasításokat
Villanások vagy szikrák	a. Mikrohullámú sütőben kerülendő anyagok voltak használva. b. A sütő üres állapotban működik. c. A kiömlött étel maradt a sütőtérben.	a. Csak mikrohullámú sütőben használható főzőedényeket használjon. b. Ne működtesse üres sütővel. c. Tisztítsa meg a sütőtérrel puha, nedves ruhával.
Egyenetlenül főtt ételek	a. Mikrohullámú sütőben kerülendő anyagok voltak használva. b. Az étel nincs teljesen kiolvasztva. c. A sütési idő, a teljesítményszint nem megfelelő. d. Az étel nincs átfordítva vagy megkeverve.	a. Csak mikrohullámú sütőben használható főzőedényeket használjon. b. Ételt teljes kiolvasztásra. c. Használjon megfelelő sütési időt, teljesítményszintet. d. Fordítsa meg vagy keverje meg az ételt.
Túlfőzött ételek	A sütési idő, a teljesítményszint nem megfelelő.	Használjon megfelelő sütési időt, teljesítményszintet.
Alulfőzött ételek	a. Mikrohullámú sütőben kerülendő anyagok voltak használva. b. Az étel nincs teljesen kiolvasztva. c. A sütő szellőzőnyílásai el vannak zárva. d. A sütési idő, a teljesítményszint nem megfelelő.	a. Csak mikrohullámú sütőben használható főzőedényeket használjon. b. Ételt teljes kiolvasztásra. c. Ellenőrizze, hogy a sütő szellőzőnyílásai nincsenek-e elzárva. d. Használjon megfelelő sütési időt, teljesítményszintet
Nem megfelelő leolvasztás	a. Mikrohullámú sütőben kerülendő anyagok voltak használva. b. A sütési idő, a teljesítményszint nem megfelelő. c. Az étel nincs átfordítva vagy megkeverve.	a. Csak mikrohullámú sütőben használható főzőedényeket használjon. b. Használjon megfelelő sütési időt, teljesítményszintet. c. Fordítsa meg vagy keverje meg az ételt.



Az elektromos és elektronikus berendezések hulladékairól szóló irányelv szerint az elektromos és elektronikus berendezések hulladékait külön kell gyűjteni és kezelni. Ha a jövőben bármikor le kell selejteznie ezt a terméket, NE a háztartási hulladékkal együtt dobja ki. Küldje el ezt a terméket az elektromos és elektronikus berendezések hulladékainak gyűjtőhelyére, ahol van ilyen.



**#DetailsMatter**

# MANUAL DE INSTRUCȚIUNI

## CUPTOR CU MICROUND

MW3-AG25PFI(MG)

Vă rugăm să citiți acest manual de instrucțiuni înainte de utilizare.

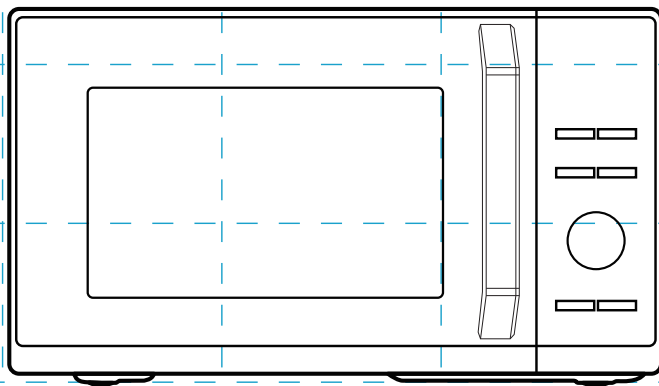

**TOSHIBA**

# CUPRINS

## SIGURANȚA PRODUSELOR

Măsuri de precauție pentru a evita eventuale expuneri la energia excesivă a microundei ..	RO-01
Specificații .....	RO-02
Instrucțiuni de siguranță importante .....	RO-03
Instalare cu împământare pentru a reduce riscul de rănire a persoanelor .....	RO-08
Curățare .....	RO-10
Ustensile .....	RO-11
Materiale pe care le puteți utiliza în cuptorul cu microunde .....	RO-12
Materialele care nu pot fi utilizate în cuptorul cu microunde .....	RO-14

## SETAREA PRODUSULUI

Instalarea cuptorului .....	RO-15
-----------------------------	-------

## INSTRUCȚIUNI DE UTILIZARE

Înainte de prima utilizare .....	RO-18
Funcționare .....	RO-19
Panou de control și caracteristici .....	RO-19
1. Setarea ceasului .....	RO-20
2. Setarea cronometrului de bucătărie .....	RO-21
3. Gătire cu microunde .....	RO-21
4. Gătitul la grătar .....	RO-22
5. Gătit combinat .....	RO-23
6. Dezghețare în funcție de timp .....	RO-24
7. Dezghețare în funcție de greutate .....	RO-24
8. Gătire rapidă .....	RO-25
9. Gătit în mai multe etape .....	RO-25

10. Meniu automat .....	RO-26
11. Funcția de blocare pentru copii .....	RO-28
12. Funcția de interogare .....	RO-28

## **CURĂȚARE ȘI ÎNTREȚINERE**

Curățare .....	RO-29
Depanare .....	RO-31



### **NOTĂ**

ÎNAINTE DE A UTILIZA ACEST PRODUS, CITIȚI, ÎNȚELEGEȚI ȘI RESPECTAȚI ACESTE INSTRUCȚIUNI. NU UITAȚI SĂ PĂSTRAȚI ACEASTĂ LISTĂ DE CĂRȚI PENTRU REFERINȚE VIITOARE.

## SIGURANȚA PRODUSELOR

### MĂSURI DE PRECAUȚIE PENTRU A EVITA O EVENTUALĂ EXPUNERE LA ENERGIA EXCESIVĂ A MICROUNDUI ENERGIA MICROUNDURILOR

---

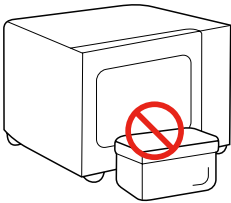
- (a). Nu încercați să folosiți acest cuptor cu ușa deschisă, deoarece acest lucru poate duce la o expunere dăunătoare la energia cuptorului cu microunde. Este important să nu rupeți sau să modificați dispozitivele de blocare de siguranță.
- (b). Nu așezați niciun obiect între fața frontală a cuptorului și ușa și nu lăsați murdăria sau reziduurile de curățare să se acumuleze pe suprafețele de etanșare.
- 
- (c). **AVERTISMENT:** Dacă ușa sau garniturile de etanșare ale ușii sunt deteriorate, cuptorul nu trebuie să fie utilizat până când nu este reparat de o persoană competentă.

### ANEXĂ

---

În cazul în care aparatul nu este menținut într-o stare bună de curățenie, suprafața acestuia s-ar putea degrada și ar putea afecta durata de viață a aparatului și ar putea duce la o situație periculoasă.



## SPECIFICAȚII

---

MODEL	MW3-AG25PFI(MG)
TENSIUNE/FRECVENȚĂ NOMINALĂ	230-240 V~ 50 Hz
PUTERE INTRARE MICROUNDRE	1400 W
PUTERE IEȘIRE MICROUNDRE	900 W
INTRARE NOMINALĂ (GRĂȚAR)	1000-1100 W



Toate imaginile din acest manual sunt doar în scop ilustrativ; acestea pot fi ușor diferite de echipamentul achiziționat, vă rugăm să consultați produsul real.

# INSTRUCȚIUNI DE SIGURANȚĂ IMPORTANTE



## AVERTISMENT

Pentru a reduce riscul de incendiu, de electrocutare, de rănire a persoanelor sau de expunere la energia excesivă a cuptorului cu microunde atunci când utilizați aparatul, respectați precauțiile de bază, inclusiv următoarele:

 Citiți și respectați în special: **„MĂSURILE DE PRECAUȚIE PENTRU A EVITA POSIBILE EXPUNERI LA ENERGIE EXCESIVĂ A MICROUNDDELOR”**.

 Acest aparat poate fi utilizat de copii cu vârsta de peste 8 ani și de persoane cu capacități fizice, senzoriale sau mentale reduse sau cu lipsă de experiență și cunoștințe, dacă acestea au fost supravegheate sau instruite cu privire la utilizarea aparatului în condiții de siguranță și dacă înțeleg pericolele implicate. Copiii nu trebuie să se joace cu aparatul. Curățarea și întreținerea nu trebuie efectuate de copii fără supraveghere.

 Țineți aparatul și cablul acestuia departe de copiii mai mici de 8 ani.

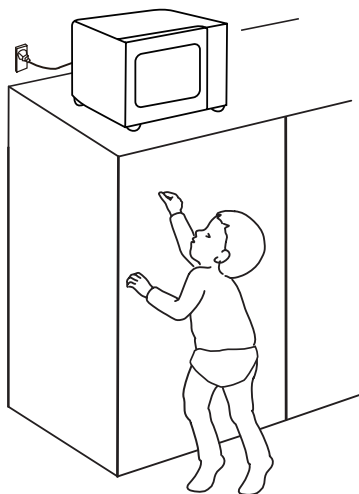

 În cazul în care cablul de alimentare este deteriorat, acesta trebuie să fie înlocuit de către

# INSTRUCȚIUNI DE SIGURANȚĂ IMPORTANTE

producător, de agentul său de service sau o persoană calificată, pentru a se evita astfel pericolele.

---

 **AVERTISMENT:** Asigurați-vă că aparatul este oprit înainte de înlocuirea lămpii pentru a evita posibilitatea unui șoc electric.

---

 **AVERTISMENT:** Este periculos ca orice persoană, alta decât o persoană competentă, să efectueze orice operațiune de întreținere sau de reparație care implică îndepărtarea unui capac care oferă protecție împotriva expunerii la energia cu microunde.

---

 **AVERTISMENT:** Lichidele și alte alimente nu trebuie încălzite în recipiente sigilate, deoarece acestea pot exploda.

 Atunci când încălziți alimente în recipiente de plastic sau de hârtie, supravegheați cuptorul din cauza posibilității de aprindere.

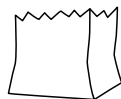

---

 Folosiți numai ustensile care sunt adecvate pentru cuptoarele cu microunde.

---

 În cazul în care se degajă fum, opriți sau scoateți aparatul din priză și țineți ușa închisă pentru a înăbuși eventualele flăcări.

---

 Încălzirea cu microunde a băuturilor poate avea ca rezultat o fierbere eruptivă întârziată, prin urmare trebuie să aveți grijă la manipularea recipientului.

---

 Conținutul biberoanelor și al borcănelelor de mâncare pentru copii trebuie amestecat sau agitat, iar

# INSTRUCȚIUNI DE SIGURANȚĂ IMPORTANTE

temperatura trebuie verificată înainte de consum, pentru a evita arsurile.

 Cuptorul trebuie curățat în mod regulat și trebuie îndepărtate toate depunerile de alimente. Vă rugăm să păstrați zona ghidului de undă curată. Utilizați o cârpă moale și umedă pentru a o curăța atunci când există reziduuri de stropi de alimente în zona ghidului de undă sau în cavitate. Necurățarea reziduurilor alimentare poate provoca scânteii inofensive sau fum în cavitatea cuptorului cu microunde, poate apărea și decolorarea cavității.

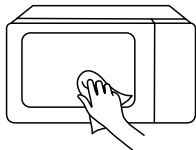

 Neîntreținerea cuptorului într-o stare curată ar putea duce la deteriorarea suprafeței care ar putea afecta negativ durata de viață a aparatului și,

eventual, ar putea duce la o situație periculoasă.

 Utilizați numai sonda de temperatură recomandată pentru acest cuptor. (pentru cuptoarele prevăzute cu posibilitatea de a utiliza o sondă de detectare a temperaturii).

 Cuptorul cu microunde trebuie să funcționeze cu ușa decorativă deschisă. (pentru cuptoarele cu ușa decorativă.)

 Acest aparat este destinat utilizării în gospodărie și în aplicații similare precum:

1. zone de bucătărie pentru personal din magazine, birouri și alte medii de lucru;
2. de către clienții din hoteluri, moteluri și alte medii de tip rezidențial;
3. case de la fermă;
4. medii de tip pensiune și mic dejun.

# INSTRUCȚIUNI DE SIGURANȚĂ IMPORTANTE

 Cuptorul cu microunde este destinat încălzirii alimentelor și băuturilor. Uscarea alimentelor sau a îmbrăcăminte și încălzirea pernuțelor de încălzire, a papucilor, a bureților, a cârpelor umede și a altor obiecte similare pot duce la risc de rănire, aprindere sau incendiu.

 Suprafața posterioară a aparatelor trebuie să fie amplasată pe un perete.

 Temperatura suprafețelor accesibile poate fi ridicată atunci când aparatul funcționează.

 **AVERTISMENT:** Atunci când aparatul funcționează în modul combinat, copiii trebuie să folosească cuptorul numai sub supravegherea unui adult, din cauza temperaturilor generate.

 Aparatul este destinat să fie utilizat independent.

 Ouăle în coajă și ouăle fierte tari întregi nu trebuie încălzite în cuptoare cu microunde, deoarece pot exploda, chiar și după ce încălzirea cu microunde a luat sfârșit.

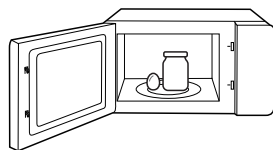



 Cuptorul cu microunde nu trebuie să fie amplasat într-un dulap decât dacă a fost testat într-un dulap.

 Recipientele metalice pentru alimente și băuturi nu sunt permise în timpul gătitului la microunde.

 Aparatul nu trebuie curățat cu un aparat de curățare cu aburi.

# INSTRUCȚIUNI DE SIGURANȚĂ IMPORTANTE

 Aparatele nu sunt destinate să fie acționate cu ajutorul unui temporizator extern sau al unui sistem de telecomandă separat.

 Aparatul nu trebuie să fie instalat în spatele unei uși decorative pentru a evita supraîncălzirea. (Acest lucru nu se aplică în cazul aparatelor cu ușa decorativă.)

**CITIȚI CU ATENȚIE ȘI PĂSTRAȚI  
PENTRU REFERINȚE VIITOARE**

# INSTALARE CU ÎMPĂMÂNTARE PENTRU A REDUCE RISCUL DE RĂNIRE A PERSOANELOR

Acest aparat trebuie să fie împământat. În cazul unui scurtcircuit electric, împământarea reduce riscul de șoc electric prin faptul că oferă un fir de evacuare a curentului electric.

Acest aparat este echipat cu un cablu cu un fir de împământare cu o fișă de împământare. Ștecherul trebuie să fie conectat la o priză care este instalată și împământată în mod corespunzător.

**AVERTISMENT** - Utilizarea necorespunzătoare a împământării poate duce la un risc de electrocutare. Consultați un electrician sau un service calificat dacă instrucțiunile de împământare nu sunt înțelese complet sau dacă există îndoieli cu privire la împământarea corectă a aparatului.

Dacă este necesar să utilizați un prelungitor, utilizați numai un prelungitor cu 3 fire.



**PERICOL**

Pericol de șoc electric:

Atingerea unora dintre componentele interne poate provoca vătămări corporale grave sau chiar moartea. Nu dezasamblați acest aparat.

# INSTALARE CU ÎMPĂMÂNTARE PENTRU A REDUCE RISCUL DE RĂNIRE A PERSOANELOR



## AVERTISMENT

Pericol de șoc electric:

Utilizarea necorespunzătoare a împământării poate duce la șocuri electrice. Nu conectați la priză până când aparatul nu este instalat și împământat corespunzător.

1. Este prevăzut un cablu de alimentare scurt pentru a reduce riscurile rezultate din încurcarea sau împiedicarea de un cablu mai lung.
2. În cazul în care se utilizează un cablu lung sau un prelungitor:
  - (1). Valoarea electrică marcată a setului de cablu sau a prelungitorului trebuie să fie cel puțin la fel de mare ca valoarea electrică a aparatului.
  - (2). Cablul prelungitor trebuie să fie un cablu cu 3 fire cu împământare.
  - (3). Cablul mai lung ar trebui să fie aranjat astfel încât să nu se prelingă peste blatul sau masa de lucru, unde poate fi tras de copii sau de care se pot împiedica neintenționat.



# CURĂȚARE

Asigurați-vă că ați deconectat aparatul de la sursa de alimentare.

1. Curățați cavitatea cuptorului după utilizare cu o cârpă ușor umedă.
2. Curățați accesoriile în mod obișnuit cu apă cu săpun.
3. Cadrul și garnitura ușii, precum și piesele învecinate trebuie curățate cu grijă cu o cârpă umedă atunci când sunt murdare.
4. Nu utilizați produse de curățare abrazive dure sau răzuitoare metalice ascuțite pentru a curăța sticla ușii cuptorului, deoarece acestea pot zgâria suprafața, ceea ce poate duce la spargerea sticlei.
5. Sfat de curățare --- Pentru o curățare mai ușoară a pereților cavității pe care alimentele gătite îi pot atinge: Pune o jumătate de lămâie într-un castron, adaugă 300 ml (1/2 litri) apă și încălzi la 100% puterea cuptorului cu microunde timp de 10 minute. Ștergeți cuptorul cu o cârpă moale și uscată.

# USTENSILE



## PRECAUȚIE

Pericol de vătămare corporală:

Este periculos ca orice persoană, alta decât o persoană competentă, să efectueze orice operațiune de întreținere sau de reparație care implică îndepărtarea unui capac care oferă protecție împotriva expunerii la energia cu microunde. Consultați instrucțiunile de pe "**Materiale pe care le puteți folosi în cuptorul cu microunde**" sau "**materialele nu pot fi utilizate în cuptorul cu microunde**".

Este posibil ca anumite ustensile nemetalice să nu poată fi folosite în siguranță la microunde. Dacă aveți îndoieli, puteți testa ustensila în cauză urmând procedura de mai jos.

## Testul cu ustensile:

1. Umpleți un recipient rezistent la cuptorul cu microunde cu 1 cană de apă rece (250 ml) împreună cu ustensila în cauză.
2. Gatiti la putere maxima timp de 1 min.
3. Pipăiți cu atenție ustensila. Dacă ustensilele goale sunt calde, nu le folosiți pentru gătit la microunde.
4. Nu depășiți timpul de gătire de 1 minut.

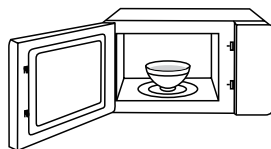





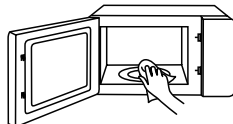











## NOTĂ

PĂSTRAȚI CURATĂ ZONA CAVITĂȚII ȘI A GHIDULUI DE UNDĂ

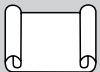

# MATERIALE PE CARE LE PUTEȚI UTILIZA ÎN CUPTORUL CU MICROUND

USTENSILE	REMARCI
 Vas de rumenit	Urmați instrucțiunile producătorului. Partea inferioară a vasului de rumenit trebuie să fie la cel puțin 3/16 inch (5 mm) deasupra plăcii rotative. Utilizarea incorectă poate cauza ruperea plăcii rotative. 
 Vesela	Doar materiale sigure pentru cuptorul cu microunde. Urmați instrucțiunile producătorului. Nu folosiți vase crăpate sau ciobite. 
 Borcane de sticlă	Scoateți întotdeauna capacul. Folosiți doar pentru a încălzi alimentele până când acestea sunt abia calde. Majoritatea borcanelor de sticlă nu sunt rezistente la căldură și se pot sparge. 
 Sticlă	Numai sticlă rezistentă la căldură pentru cuptor. Asigurați-vă că nu există ornamente metalice. Nu folosiți vase crăpate sau ciobite. 
 Pungi pentru gătit în cuptor	Urmați instrucțiunile producătorului. Nu închideți cu cravată metalică. Faceți fante pentru a permite aburului să iasă. 
 Farfurii și pahare de hârtie	Utilizați doar pentru gătit/încălzire pe termen scurt. Nu lăsați cuptorul nesupravegheat în timpul gătitului. 
 Prosoape de hârtie	Se utilizează pentru a acoperi alimentele pentru reîncălzire și pentru a absorbi grăsimea. A se utiliza numai sub supraveghere pentru o perioadă scurtă de timp. 
 Hârtie pergament	Folosiți-o ca un capac pentru a preveni stropirea sau ca o învelitoare pentru gătit la aburi. 

# MATERIALE PE CARE LE PUTEȚI UTILIZA ÎN CUPTORUL CU MICROUND

## USTENSILE

## REMARCI



Plastic

Doar materiale sigure pentru cuptorul cu microunde. Urmați instrucțiunile producătorului. Ar trebui să fie etichetate cu mențiunea "sigur pentru cuptorul cu microunde". Unele recipiente din plastic se înmoaie, deoarece alimentele din interior se încălzesc. "Sacii de fierbere" și pungile de plastic bine închise trebuie să fie tăiate, perforate sau aerisite conform indicațiilor de pe ambalaj.



Folie de plastic

Doar materiale sigure pentru cuptorul cu microunde. Se utilizează pentru a acoperi alimentele în timpul gătitului pentru a reține umiditatea. Nu permiteți ca folia de plastic să atingă alimentele.



Termometre

Numai în condiții de siguranță pentru microunde (termometre cu carne și bomboane).



Hârtie cerată

Utilizați ca capac pentru a preveni stropirea și rețineți umiditatea.



# MATERIALELE CARE NU POT FI UTILIZATE ÎN CUPTORUL CU MICROUND

## USTENSILE

## REMARCI

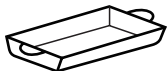

Tavă din aluminiu

Poate provoca formarea de arcuri electrice.  
Transferați alimentele în vasul rezistent la microunde.



Carton alimentar cu  
mâner metalic

Poate provoca formarea de arcuri electrice.  
Transferați alimentele în vasul rezistent la microunde.



Ustensile din metal sau  
cu garnituri metalice

Metalul protejează alimentele de energia cuptorului  
cu microunde. Garnitura metalică poate provoca  
formarea de arcuri electrice.



Legături din metal

Poate cauza formarea unui arc electric și poate  
provoca un incendiu în cuptor.

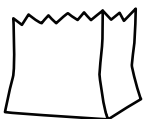

Pungi de hârtie

Poate provoca un incendiu în cuptor.



Spumă de plastic

Spuma de plastic se poate topi sau contamina lichidul  
din interior atunci când este expusă la temperaturi  
ridicate.



Lemn

Lemnul se va usca atunci când este utilizat în cuptorul  
cu microunde și se poate despică sau crăpa.



# SETAREA PRODUSULUI

## INSTALAREA CUPTORULUI

### DENUMIRI DE PIESE ȘI ACCESORII PENTRU CUPTORUL CU MICROUNDE

Scoateți cuptorul și toate materialele din cutie și din cavitatea cuptorului.

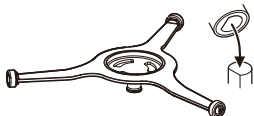

Ansamblu inel placă rotativă

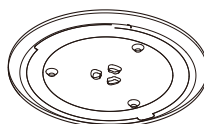

Tavă de sticlă

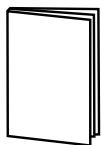

Manual de Instrucțiuni

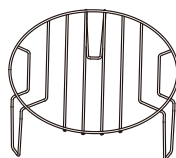

Grătar (nu poate fi folosit în funcția de microunde și trebuie așezat pe tava de sticlă)

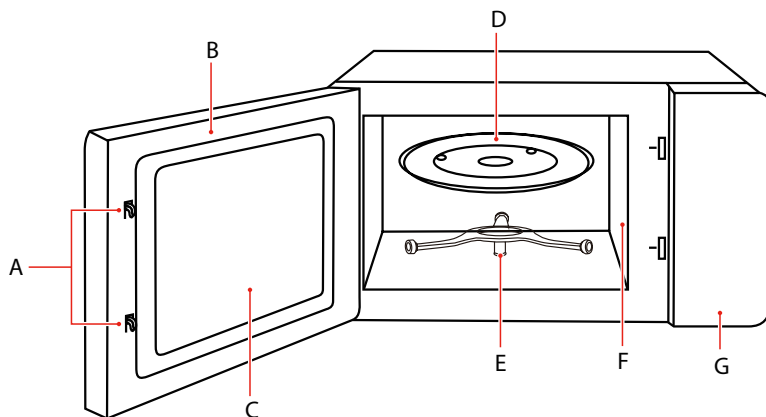

A) Sistem de blocare de siguranță

B) Ansamblu ușă

C) Fereastră pentru observare

D) Tavă de sticlă

E) Ansamblu inel-platou rotativ

F) Capacul ghidului de undă

G) Panou de comandă



**NOTĂ**

În cazul în care există diferențe între aparat și imaginile din acest manual, prevalează produsul.

# INSTALAREA CUPTORULUI

## INSTALAREA PLATOULUI ROTATIV

Curățați compartimentul de gătit și așezați placa rotativă.

În cazul instalațiilor noi, asigurați-vă că toate ambalajele și benzile de transport au fost îndepărtate de pe axul platoului rotativ.

Înainte de a utiliza aparatul pentru a pregăti alimente pentru prima dată, va trebui să puneți corect placa rotativă. Trebuie să curățați compartimentul de gătit și accesoriile. Le puteți referi și la secțiunea de curățare.

Cum se pune platoul rotativ la loc:

1. Așezați ansamblul inelar al plăcii rotative ② în locașul din compartimentul de gătit.
2. Așezați tava de sticlă ① pe ansamblurile inelare ale plăcii rotative ②.

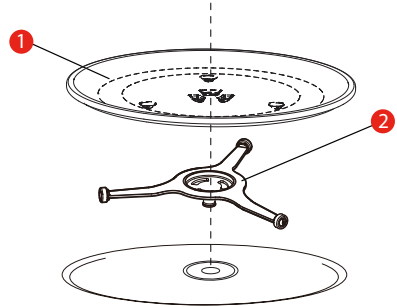

1) Tavă de sticlă

2) Ansamblu inel placă rotativă

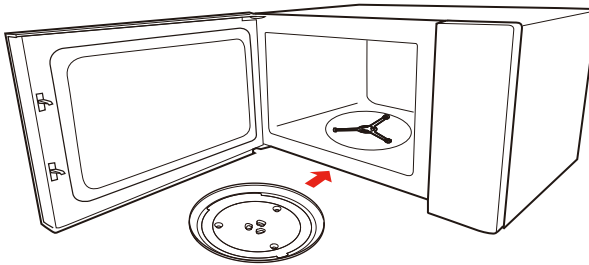

**NOTĂ**

- Niciodată nu utilizați aparatul fără placa turnantă. Asigurați-vă că este poziționată corespunzător. Placa turnantă se poate roti în sensul acelor de ceasornic sau în sens invers.
- Nu așezați niciodată tava de sticlă cu susul în jos. Tava de sticlă nu trebuie niciodată restricționată.
- Atât tava de sticlă, cât și ansamblul inel-platou rotativ trebuie să fie folosite întotdeauna în timpul gătitului.
- Toate alimentele și recipientele cu alimente sunt întotdeauna așezate pe tava de sticlă pentru gătit.
- Nu restricționați niciodată mișcarea plăcii rotative.
- Dacă tava de sticlă sau ansamblul inel-platou rotativ se fisurează sau se sparge, contactați cel mai apropiat centru de service autorizat.

## INSTALAREA BLATULUI

Scoateți toate materialele de ambalare și accesoriile. Examinați cuptorul pentru orice daune, cum ar fi lovituri sau uși sparte. Nu instalați dacă cuptorul este deteriorat.

Dulap: Îndepărtați orice peliculă protectoare care se găsește pe suprafața dulapului cuptorului cu microunde. Nu îndepărtați capacul ghidului de undă care este atașat de cavitatea cuptorului pentru a proteja magnetronul.

## INSTALARE

1. Selectați o suprafață plană care să ofere suficient spațiu liber pentru orificiile de admisie și/sau de evacuare.
  - a. Înălțimea minimă de instalare este de 85 cm.
  - b. Suprafața din spate a aparatului trebuie să fie așezată pe un perete. Lăsați un spațiu liber de cel puțin 30 cm deasupra cuptorului. Este necesar un spațiu liber de minim 20 cm între cuptor și pereții adiacenți.
  - c. Nu îndepărtați picioarele de pe fundul cuptorului.
  - d. Blocarea orificiilor de admisie și/sau de evacuare poate cauza deteriorarea cuptorului.
  - e. Amplasați cuptorul cât mai departe de aparate radio și televizoare. Funcționarea cuptorului cu microunde poate cauza interferențe la recepția radio sau TV.

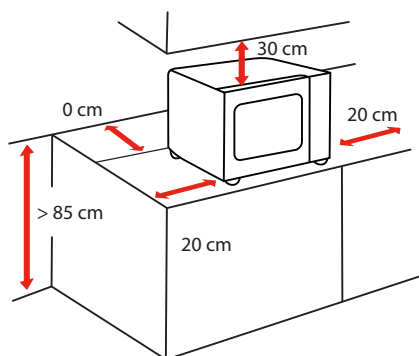

PARTE LATERALĂ	DISTANȚĂ CM
Parte superioară	30 cm
Stânga	20 cm
Dreapta	20 cm
În spate	0 cm
Partea din față	Deschis

2. Conectați cuptorul cu microunde la o priză standard de uz casnic. Asigurați-vă că tensiunea și frecvența sunt identice cu tensiunea și frecvența de pe eticheta nominală.



**NOTĂ**

- Nu instalați cuptorul deasupra unui aragaz sau a unui alt aparat care produce căldură. Dacă este instalat în apropierea sau deasupra unei surse de căldură, cuptorul ar putea fi deteriorat și garanția ar fi anulată.

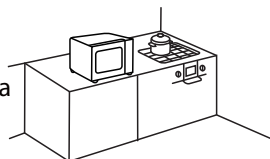

Suprafața accesibilă poate fi fierbinte în timpul funcționării



# INSTRUCȚIUNI DE UTILIZARE

## ÎNAINTE DE PRIMA UTILIZARE

**Este normal ca cuptorul să producă mirosuri neplăcute atunci când este utilizat pentru prima dată.**

Această secțiune vă spune ce trebuie să faceți înainte de a utiliza cuptorul cu microunde pentru a pregăti mâncarea pentru prima dată. Citiți în prealabil secțiunea intitulată „**SIGURANA PRODUSELOR**”.

Înainte de a putea utiliza noul aparat, va trebui să puneți placa turnantă în poziție corectă. De asemenea, trebuie să curățați compartimentul de gătit și accesoriile.



**NOTĂ**

- Niciodată nu utilizați aparatul fără placa turnantă.
- Asigurați-vă că este poziționată corespunzător. Placa turnantă se poate roti în sensul acelor de ceasornic sau în sens invers.

# FUNȚIONARE

## PANOU DE CONTROL ȘI CARACTERISTICI

---

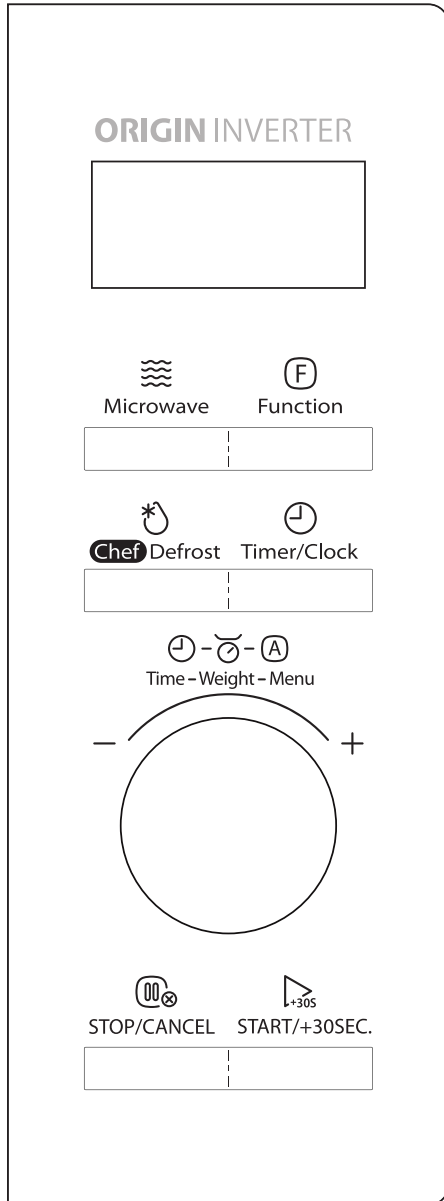

## 1. SETAREA CEASULUI

---

**a** Apăsați  Timer/Clock de două ori, se va afișa „00:00„.



**b** Rotiți butonul pentru a seta cifrele orelor.

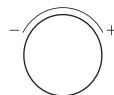

**c** Apăsați  Timer/Clock sau  START/+30SEC. pentru a confirma valorile orei.



sau



**d** Rotiți butonul pentru a seta cifrele minutelor.

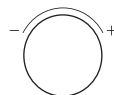

**e** Apăsați  Timer/Clock sau  START/+30SEC. pentru a confirma. Ceasul este setat.



sau



**NOTĂ**

- Ceasul este în format de 24 de ore. Dacă ceasul nu este setat, acesta nu va funcționa atunci când este alimentat.
- Pentru a reseta ceasul, repetați pașii de la a la e.

## 2. SETAREA CRONOMETRULUI DE BUCĂTĂRIE

a Apăsați  o dată, se va afișa „00:00”.



b Rotiți butonul pentru a seta timpul de dezghețare dorit. Valoarea maximă a timpului este „95:00”.

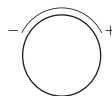

c Apăsați  pentru a confirma. Cronometrul începe numărătoarea inversă.



**NOTĂ**

- Cronometrul din bucătărie este un cronometru.
- Orice alt program nu poate fi setat în timpul cronometrului de bucătărie.

## 3. GĂTIRE CU MICROUND

Sunt disponibile 10 niveluri de putere.

NIVEL	PUTERE	AFIȘARE
1	100%	P100
2	90%	P90
3	80%	P80
4	70%	P70
5	60%	P60
6	50%	P50
7	40%	P40
8	30%	P30
9	20%	P20
10	10%	P10

**a** Apăsați  de mai multe ori pentru a alege nivelul de putere.

sau

**c** Apăsați  o dată, apoi rotiți butonul pentru a seta nivelul de putere.

Sunt disponibile 10 niveluri de putere.



**b** Apăsați  pentru a confirma nivelul.



**c** Rotiți butonul pentru a seta timpul de gătire, valoarea maximă a timpului este „95:00”.

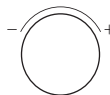

**d** Apăsați  pentru a începe gătitul.



## 4. GĂTITUL LA GRĂTAR

**a** Apăsați  o dată, se va afișa „G-1”.



**b** Apăsați  pentru a confirma modul.



**c** Rotiți butonul pentru a seta timpul de gătire, valoarea maximă a timpului este „95:00”.



**d** Apăsați  **START/+30SEC.** pentru a începe gătitul.

  
**START/+30SEC.**



• Soneria va suna pentru a vă reaminti să întoarceți alimentele în timpul gătirii. Dacă nu se efectuează nicio operațiune, cuptorul va continua să funcționeze.

## 5. GĂTIT COMBINAT

**a** Apăsați  **Function** pentru a alege modul de gătit pe care îl doriți. Sunt disponibile „C-1, C-2”.

  
**Function**

**sau**  
**c** Apăsați  **Function** o dată, apoi rotiți butonul pentru a alege modul de gătire.

  
**Function**



**b** Apăsați  **START/+30SEC.** pentru a confirma modul.

  
**START/+30SEC.**

**c** Rotiți butonul pentru a seta timpul de gătire, valoarea maximă a timpului este „95:00”.

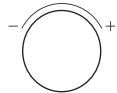

**d** Apăsați  **START/+30SEC.** pentru a începe gătitul.

  
**START/+30SEC.**

### DIAGRAMĂ GĂTIT COMBINAT

FUNCTII	AFIȘARE	PUTEREA CUPTORULUI CU MICROWANDE	PUTEREA GRĂȚARULUI
Combi. 1	C-1	55%	45%
Combi. 2	C-2	36%	64%

## 6. DEZGHEȚARE ÎN FUNCȚIE DE TIMP

**a** Apăsați  o dată, se va afișa „dEF1”.



**b** Rotiți butonul pentru a seta timpul de dezghețare dorit. Valoarea maximă a timpului este „95:00”.

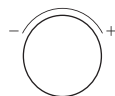

**c** Apăsați  pentru a începe dezghețarea.



**NOTĂ**

- Soneria va suna pentru a vă reaminti de întoarcerea alimentelor în timpul dezghețării. Dacă nu se efectuează nicio operațiune, cuptorul va continua să funcționeze.
- Puterea de dezghețare este P30 și nu poate fi schimbată.

## 7. DEZGHEȚARE ÎN FUNCȚIE DE GREUTATE

**a** Apăsați  în mod repetat pentru a alege tipul de aliment și apoi se va afișa „dEF2”, „dEF3” sau „dEF4”.



**b** Rotiți butonul pentru a seta greutatea alimentelor, ar trebui să fie între „100 g-2000 g”.

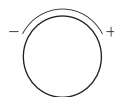

**c** Apăsați  pentru a începe dezghețarea.



AFIȘAJ LED

MÂNCARE

GREUTATE

dEF2

Carne

100 g-2000 g

dEF3

PUI

100 g-2000 g

dEF4

Pește

100 g-2000 g



**NOTĂ**

- Soneria va suna pentru a vă reaminti de întoarcerea alimentelor în timpul dezghețării. Dacă nu se efectuează nicio operațiune, cuptorul va continua să funcționeze.

## 8. GĂTIRE RAPIDĂ

**a** Rotiți butonul la stânga pentru a seta timpul de gătire cu 100% putere.

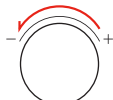

**b** Rotiți butonul pentru a regla timpul de gătire. Valoarea maximă a timpului este „95:00”.

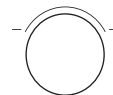

**c** Apăsați  pentru a începe gătitul.



**a** Apăsați  o dată pentru a găti cu un nivel de putere de 100% cu 30 de secunde direct. Fiecare apăsare a aceleiași taste poate crește cu 30 de secunde, iar valoarea maximă a timpului este „95:00”.



## 9. GĂTIT ÎN MAI MULTE ETAPE

Exemplu: Dezghețați alimentele timp de 5 minute și apoi gătiți-le la o putere de 80% din puterea cuptorului cu microunde timp de 7 minute.

**a** Apăsați  o dată, se va afișa „DEF1”.



**b** Rotiți butonul pentru a seta timpul de dezghețare dorit de 5 minute.

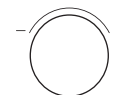

**c** Apăsați  în mod repetat până când se afișează „P80”.



**d** Apăsați  pentru a confirma nivelul.





- e** Rotiți butonul pentru a seta timpul de gătire de 7 minute.

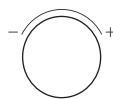

- f** Apăsați  pentru a începe gătitul.



**NOTĂ**

- Pot fi setate două etape de gătire în cazul gătitului în mai multe etape.
- Dacă setați funcția de dezghețare, aceasta va funcționa automat în prima etapă.
- Cronometrul bucătăriei, meniul automat, și viteza de gătire nu pot fi setate ca una dintre cele mai multe etape.

## 10. MENIU AUTOMAT

- a** În modul așteptare, întoarceți butonul spre dreapta o dată, iar apoi „A-1” se va afișa.

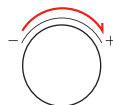

- b** Rotiți butonul în mod repetat pentru a alege meniul de care aveți nevoie. Cele 7 meniuri automate sunt disponibile.

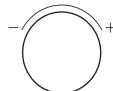

- c** Apăsați  pentru a confirma.



- d** Rotiți butonul pentru a seta greutatea alimentelor.

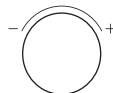

- e** Apăsați  pentru a începe gătitul.



## DIAGRAMĂ MENIU AUTOMAT

MENIU	GREUTATE/ CANTITATE	AFIȘARE	NIVELUL DE PUTERE
A-1 Popcorn	50 g 100 g	50 g 100 g	P100
A-2 Cartof	1 (230 g) 2 (460 g) 3 (690 g)	1 2 3	P100
A-3 Pizza	200 g 400 g	200 g 400 g	P100
A-4 Legume congelate	200 g 300 g 400 g	200 g 300 g 400 g	P100
A-5 Băuturi	1 cană (120 ml) 2 căni (240 ml) 3 căni (360 ml)	1 2 3	P100
A-6 Farfuria mea (Farfurie pentru cină)	250 g 350 g 500 g	250 g 350 g 500 g	P100
A-7 Carne (carne de porc)	250 g 350 g 450 g	250 g 350 g 450 g	P80

## 11. FUNCȚIA DE BLOCARE PENTRU COPII

Puteți utiliza această funcție pentru a împiedica copiii să pornească accidental cuptorul.

- a** Pentru a activa blocarea:

În modul de așteptare, apăsați și mențineți apăsat  STOP/CANCEL timp de trei secunde. Se aude un semnal sonor și se va afișa pictograma blocată.



- b** Pentru a dezactiva blocarea:

În starea blocat, apăsați și mențineți apăsat  STOP/CANCEL timp de trei secunde. Se aude un semnal sonor.



## 12. FUNCȚIA DE INTEROGARE

- a** Când cuptorul este în timpul gătitului, apăsați  Timer/Clock timp curent va apărea timp de trei secunde pe afișaj.



- b** În starea de gătit cu microunde, apăsați  Microwave pentru a întreba despre nivelul de putere. Se va afișa timp de trei secunde.



- c** În starea de preparare la grătar și în starea de preparare combinată, apăsați  Function pentru a întreba despre modul de preparare. Se va afișa timp de trei secunde.



# CURĂȚARE ȘI ÎNTREȚINERE

## CURĂȚARE

Cu o bună îngrijire și curățare, aparatul dvs. își va păstra aspectul și va rămâne pe deplin funcțional pentru o lungă perioadă de timp. Vă vom explica aici cum trebuie corect să îngrijiți și să curățați aparatul dvs.



**AVERTISMENT**

- Sticla zgâriată din ușa aparatului se poate transforma într-o fisură. Nu utilizați un răzuitor de sticlă, agenți de curățare abrazivi sau detergenți.
- Suprafața aparatului se poate deteriora dacă nu este curățată corespunzător. Energia din cuptorul cu microunde se poate evacua. Curățați aparatul în mod regulat și îndepărtați imediat resturile de alimente.
- Nu scufundați aparatul în apă și nu-l curățați sub jet de apă.

### Agent de curățare

Pentru a vă asigura că diferite suprafețe nu sunt deteriorate prin utilizarea agentului de curățare greșit, respectați informațiile din tabel. Spălați bine buretele noi înainte de utilizare.

#### Nu utilizați:



Agenți de curățare duri sau abrazivi



Răzuitoare metalice sau de sticlă pentru curățarea panourilor ușilor



Răzuitoare metalice sau de sticlă pentru curățarea garniturii ușii



Tampoane sau bureți de curățare dure



Agenți de curățare cu conținut ridicat de alcool

## PARTEA FRONTALĂ A APARATULUI

### Apă caldă cu săpun:

Curățați folosind o cârpă de vase și apoi uscați cu o cârpă moale. Nu folosiți răzuitoare metalice sau de sticlă pentru curățare.

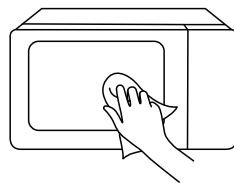

## APARAT FRONTAL CU OȚEL INOXIDABIL

---

### Apă caldă cu săpun:

Curățați folosind o cârpă de vase și apoi uscați cu o cârpă moale. Îndepărtați imediat stropii și petele de calcar, grăsime, amidon și albumină. Sub aceste pete sau stropi se poate forma coroziune. Nu utilizați detergenți de curățare a sticlei sau răzuitoare metalice sau de sticlă pentru curățare.

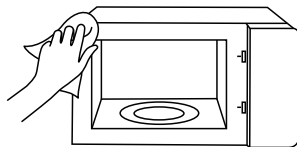

## COMPARTIMENT DE GĂTIT DIN OȚEL INOXIDABIL

---

### Apă caldă cu săpun sau soluție de oțet:

Curățați folosind o cârpă de vase și apoi uscați cu o cârpă moale. Nu folosiți spray sau alte substanțe agresive de curățare a cuptorului sau materiale abrazive. Tamponanele de spălat, bureții duri și detergenți pentru tigaie sunt, de asemenea, nepotrivite. Aceste obiecte zgărie suprafața. Lăsați suprafețele interioare să se usuce complet.

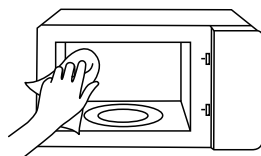

## ADÂNCITURA DIN COMPARTIMENTUL DE GĂTIT

---

### Cârpă umedă:

Apa nu trebuie lăsată să pătrundă în aparat prin intermediul plăcii turnante. Uscați unitatea plăcii turnante cu o cârpă.

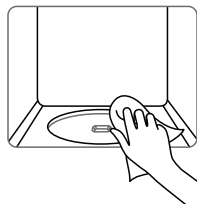

## PLATOU ROTATIV ȘI INEL CU ROLE

---

### Apă caldă cu săpun:

Atunci când puneți platoul rotativ înapoi în locașul său, aceasta trebuie să se cupleze corect.

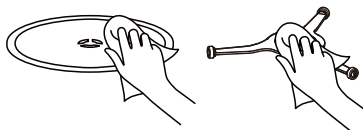

## PANOU UȘĂ

---

### Curățător sticlă:

Curățați cu o cârpă pentru vase. Nu folosiți răzuitoare de sticlă.

# DEPANARE

Verificați problema utilizând graficul de mai jos și încercați soluțiile pentru fiecare problemă. Dacă cuptorul cu microunde tot nu funcționează corect, contactați cel mai apropiat centru de service autorizat.

PROBLEME	CAUZĂ POSIBILĂ	REMEDIU POSIBIL
Cuptorul nu va porni	<ol style="list-style-type: none"><li>Cablul electric al cuptorului nu este conectat.</li><li>Ușa este deschisă.</li><li>Funcționarea greșită este setată.</li></ol>	<ol style="list-style-type: none"><li>Conectați la priză.</li><li>Închideți ușa și încercați din nou.</li><li>Verificați instrucțiunile</li></ol>
Arcul electric sau scânteia	<ol style="list-style-type: none"><li>Materiale a căror utilizare în cuptorul cu microunde trebuie evitată.</li><li>Cuptorul funcționează atunci când este gol.</li><li>Alimentele vărsate rămân în cavitate.</li></ol>	<ol style="list-style-type: none"><li>Utilizați doar vase sigure la microunde.</li><li>Nu utilizați cuptorul gol.</li><li>Curățați cavitatea cu o cârpă moale și umedă.</li></ol>
Alimente gătite neuniform	<ol style="list-style-type: none"><li>Materiale a căror utilizare în cuptorul cu microunde trebuie evitată.</li><li>Alimentele nu sunt dezghețate complet.</li><li>Timpul de gătire, nivelul de putere nu este adecvat.</li><li>Mâncarea nu este întoarsă sau amestecată.</li></ol>	<ol style="list-style-type: none"><li>Utilizați doar vase sigure la microunde.</li><li>Dezghețați complet alimentele.</li><li>Utilizați timpul de gătire corect, nivelul de putere.</li><li>Întoarceți sau amestecați alimentele.</li></ol>
Alimente gătite excesiv	Timpul de gătire, nivelul de putere nu este adecvat.	Utilizați timpul de gătire corect, nivelul de putere.
Alimente insuficient gătite	<ol style="list-style-type: none"><li>Materiale a căror utilizare în cuptorul cu microunde trebuie evitată.</li><li>Alimentele nu sunt dezghețate complet.</li><li>Porturile de ventilație ale cuptorului sunt restricționate.</li><li>Timpul de gătire, nivelul de putere nu este adecvat.</li></ol>	<ol style="list-style-type: none"><li>Utilizați doar vase sigure la microunde.</li><li>Dezghețați complet alimentele.</li><li>Verificați dacă orificiile de ventilație ale cuptorului nu sunt restricționate.</li><li>Utilizați timpul de gătire corect, nivelul de putere</li></ol>
Dezghețare necorespunzătoare	<ol style="list-style-type: none"><li>Materiale a căror utilizare în cuptorul cu microunde trebuie evitată.</li><li>Timpul de gătire, nivelul de putere nu este adecvat.</li><li>Mâncarea nu este întoarsă sau amestecată.</li></ol>	<ol style="list-style-type: none"><li>Utilizați doar vase sigure la microunde.</li><li>Utilizați timpul de gătire corect, nivelul de putere.</li><li>Întoarceți sau amestecați alimentele.</li></ol>



În conformitate cu Directiva privind deșeurile de echipamente electrice și electronice (DEEE), DEEE trebuie colectate și tratate separat. Dacă, în viitor, veți avea nevoie să eliminați acest produs, vă rugăm să NU îl aruncați cu deșeurile menajere. Vă rugăm să trimiteți acest produs la punctele de colectare DEEE, acolo unde sunt disponibile.



**#DetailsMatter**