

# 6940STAT

PARISOT INDUSTRIE 70800 SAINT LOUP SUR SEMOUSE -FRANCE-



**i HOW TO USE**



 [zQ6Jy5YM8\\_U](https://www.google.com/search?q=zQ6Jy5YM8_U)

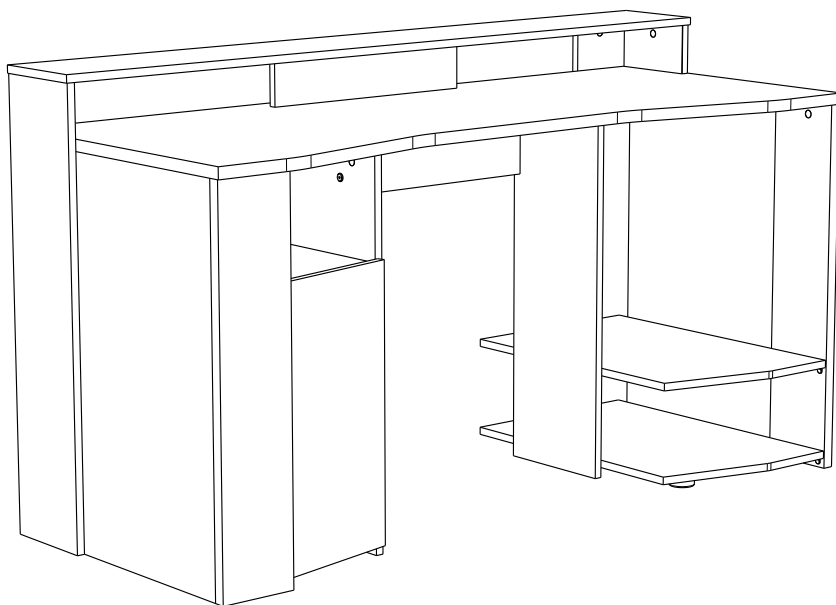

Gamme : GAMING



  
PARISOT INDUSTRIE

### FR Remerciements :

Nous vous remercions d'avoir choisi un meuble créé et fabriqué par le Groupe Parisot et espérons qu'il vous donnera entière satisfaction.

### EN Thanks:

Thank you for choosing furniture designed and manufactured by the Parisot Group. We hope you are totally satisfied with your purchase.

### DE Danksagung:

Wir danken Ihnen für den Kauf eines Frankreich von der Parisot-Gruppe entworfenen und hergestellten Möbelstücks und hoffen, dass Sie es zu Ihrer vollkommenen Zufriedenheit finden werden.

### HU Köszönet:

Köszönjük, hogy a Parisot Groupe által létrehozott és gyártott bútort választott, reméljük, hogy elégedett lesz a termékkel.

### PT Agradecimentos:

Obrigado por ter escolhido um móvel concebido e fabricado pelo Grupo Parisot, esperando que seja do seu inteiro agrado.

### IT Ringraziamenti:

Grazie per avere scelto un mobile progettato e fabbricato dal Gruppo Parisot. Speriamo soddisfatti appieno le vostre esigenze.

### NL Bedankje:

Wij bedanken u voor de aankoop van een door de Groep Parisot ontworpen en vervaardigd meubel en hopen dat u er veel plezier aan zult beleven.

### CZ Poděkování:

Děkujeme, že jste si vybrali nábytek navržený a vyrobený společností Parisot Group. Doufáme, že budete svým nákupem naprosto spokojeni.

### ES Agradecimientos:

Les damos las gracias por haber elegido un mueble diseñado y fabricado por el Groupe Parisot y esperamos que sea de su total agrado.

### PL Podziękowania:

Dziękujemy za wybór mebli stworzonych i wyprodukowanych przez Grupę Parisot. Mamy nadzieję, że będziecie Państwo w pełni zadowoleni z zakupu.

### RO Mulțumiri:

Vă mulțumim că ați ales un articol de mobilier conceput și fabricat de Grupul Parisot și sperăm că veți fi pe deplin satisfăcuți de acesta.

### RU Благодарность:

Мы благодарим вас за то, что вы выбрали мебель, созданную и произведенную Групп Паризо, и надеемся,

что вы будете полностью удовлетворены нашей продукцией.

### SK Pod'akovanie:

Ďakujeme, že ste si vybrali nábytok navrhnutý a vyrobený spoločnosťou Parisot Group. Dúfame, že budete svojim nákupom absolútne spokojní.

### SL Hvala:

Hvala, ker ste izbrali pohištvo, ki je dizajnirano in proizvedeno s strani Parisot Group. Upamo, da ste maksimalno zadovoljni z vašim nakupom.

### TR Teşekkür ederiz:

Parisot Group tarafından tasarlanan ve üretilen bu mobilyayı seçtiğiniz için teşekkür ederiz. Ürünümüzden memnun kalmanızı ümit ederiz.

### ZH 感谢 :

感谢您选择帕里索集团设计制造的家具。我们希望您对此次购买十分满意、

### AR :شكر

نشكركم لاختياركم هذه القطعة من الأثاث من تصميم وتصنيع مجموعة باريزو Parisot ونتمنى أن تتال رضاءكم.

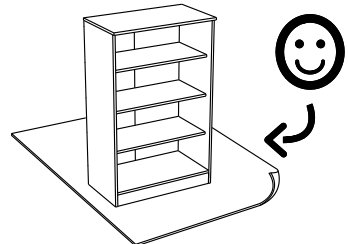
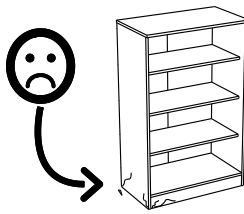
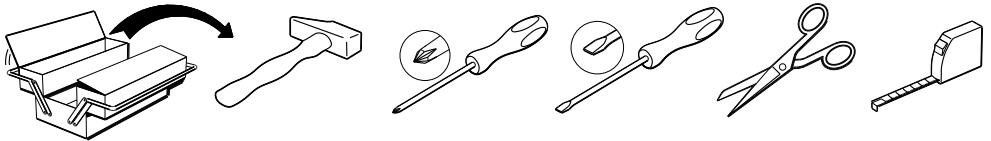



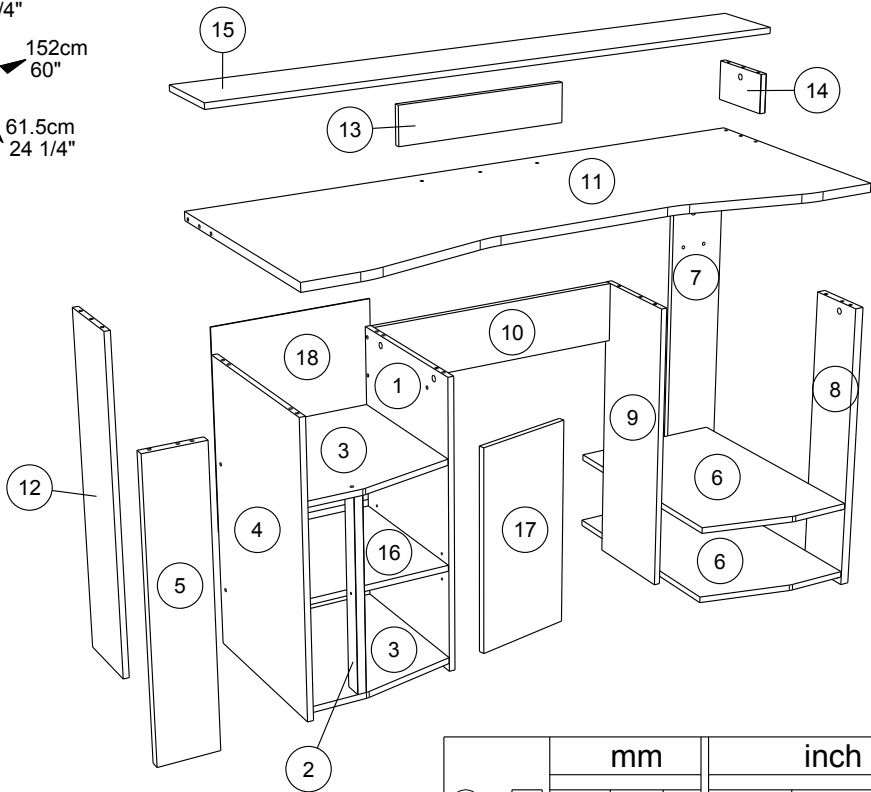



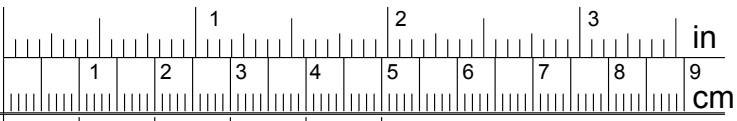

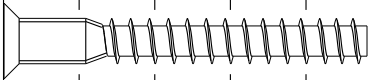

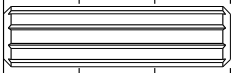
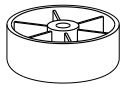
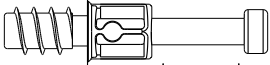
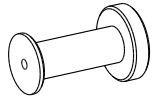
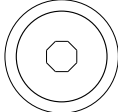
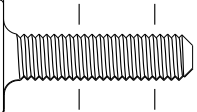

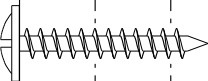



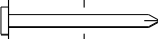

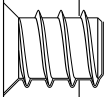

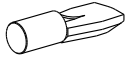
87cm  
34 1/4"  
152cm  
60"  
61.5cm  
24 1/4"

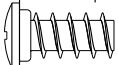

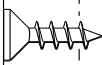
		mm			inch		
14	x 1	174	100	16	6 7/8	3 15/16	5/8
16	x 1	396	380	15	15 9/16	14 15/16	9/16
13	x 1	450	100	15	17 11/16	3 15/16	9/16
3	x 2	454	380	15	17 7/8	14 15/16	9/16
2	x 1	483	45	22	19	1 3/4	7/8
17	x 1	520	255	15	20 1/2	10 1/16	9/16
6	x 2	596	390	15	23 7/16	15 3/8	9/16
10	x 1	661	150	15	26	5 7/8	9/16
8	x 1	730	150	22	28 3/4	5 7/8	7/8
5	x 1	730	150	22	28 3/4	5 7/8	7/8
9	x 1	730	244	15	28 3/4	9 5/8	9/16
1	x 1	730	398	15	28 3/4	15 11/16	9/16
4	x 1	730	454	15	28 3/4	17 7/8	9/16
7	x 1	852	150	15	33 9/16	5 7/8	9/16
12	x 1	852	190	15	33 9/16	7 1/2	9/16
11	x 1	1500	600	22	59 1/16	23 5/8	7/8
15	x 1	1520	192	15	59 13/16	7 9/16	9/16
18	x 1	510	408	3	20 1/16	16 1/16	1/8

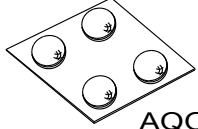
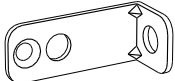
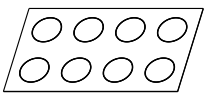
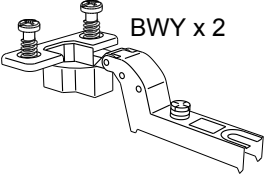
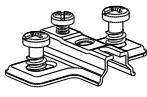

- 

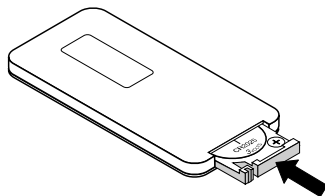
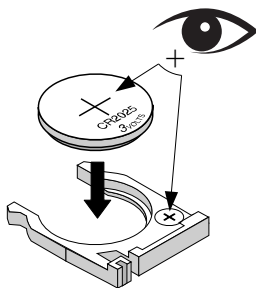
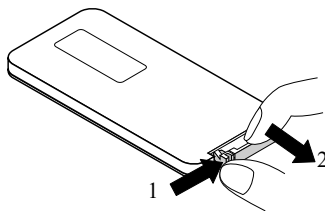
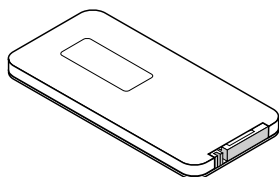
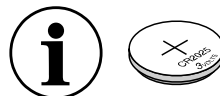
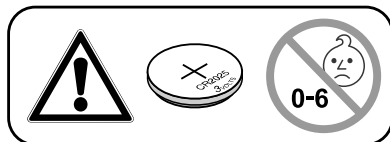
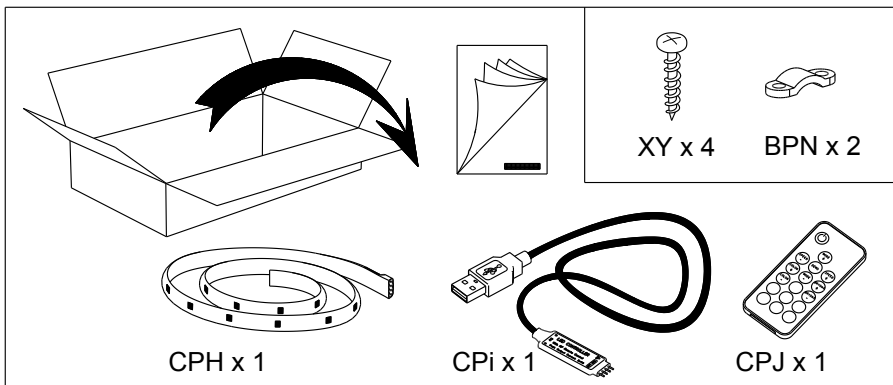
HW x 12
- 

ADM x 36

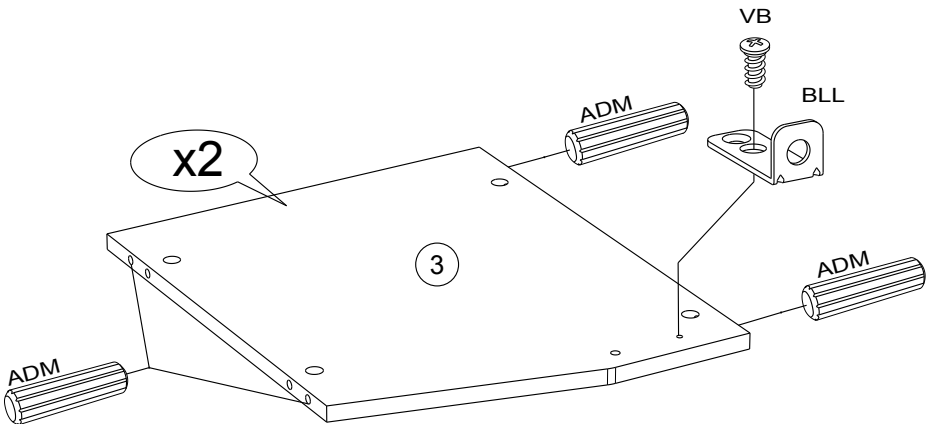
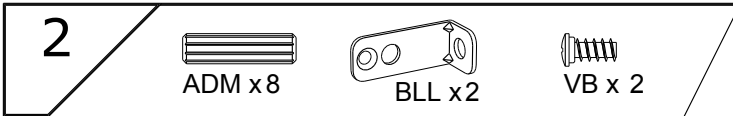
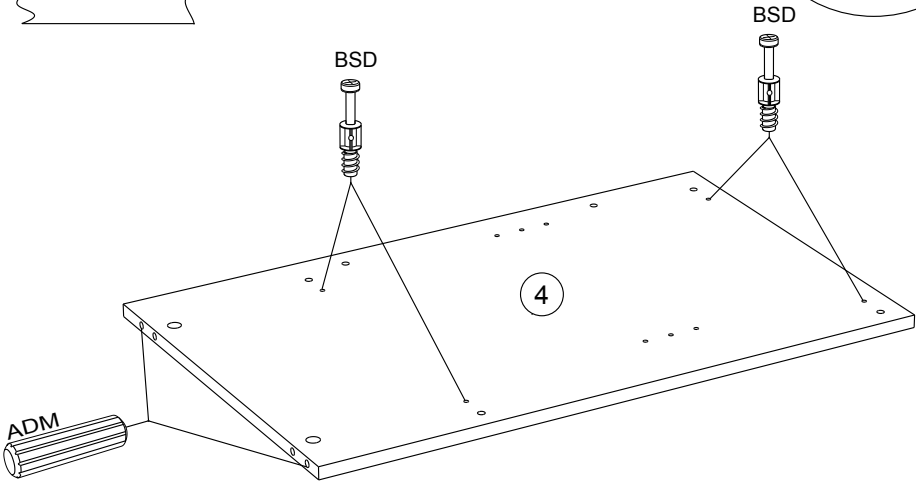
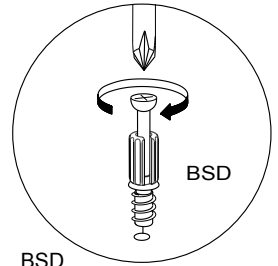
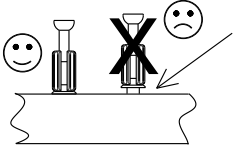
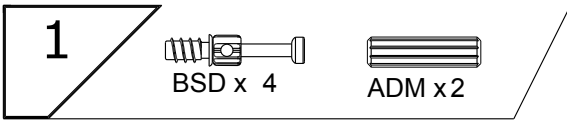
BXC x 1
- 
BSD x 25

CRV x 1
- 

BNU x 3
- 

XN x 1

HV x 1

WA x 8
- 

YB x 12
- 

AiA x 2

BAG x 4

BWD x 4
- 

VB x 14
- 

VG x 2

Ai x 25

AQO x 1
- 
BLL x 7

COL.12 x 2
- 
BWY x 2

BWU x 2

AHZ x 1



- FR Pile CR2025 non fournie.  
 EN CR2025 battery not included.  
 DE Batterie CR2025 nicht mitgeliefert.  
 ES Pila CR2025 no incluida  
 PT Pilha CR2025 não fornecida.  
 IT Pila CR2025 non fornita.  
 NL Batterij CR2025 niet bijgeleverd.  
 RU Батарейка CR2025 в комплект не входит.  
 PL Bateria CR2025 nie dołączona do zestawu.  
 SK Batéria CR2025 nie je súčasťou balenia.  
 CS CR2025 není součástí dodávky.  
 HU CR2025 akkumulátor nem tartozék.  
 RO Bateria CR2025 nu este inclusă.  
 TR CR2025 pil dahil değildir.  
 EL Η μπαταρία CR2025 δεν παρέχεται.  
 SL CR2025 baterija ni priložena.  
 ZH CR2025 電池不包括在內。  
 AR بطارية CR2025 غير المدرجة.



3



ADM x2

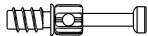

BSD x 4

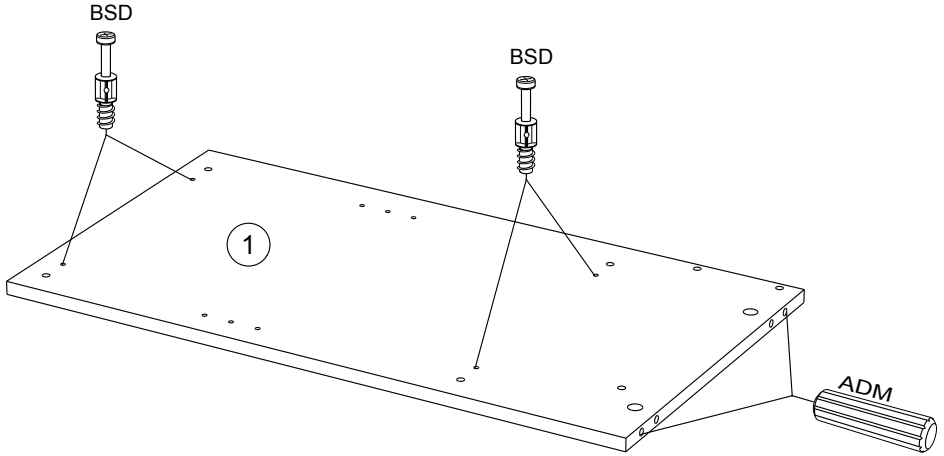

4



BLL x1



VB x 1



BWU x2

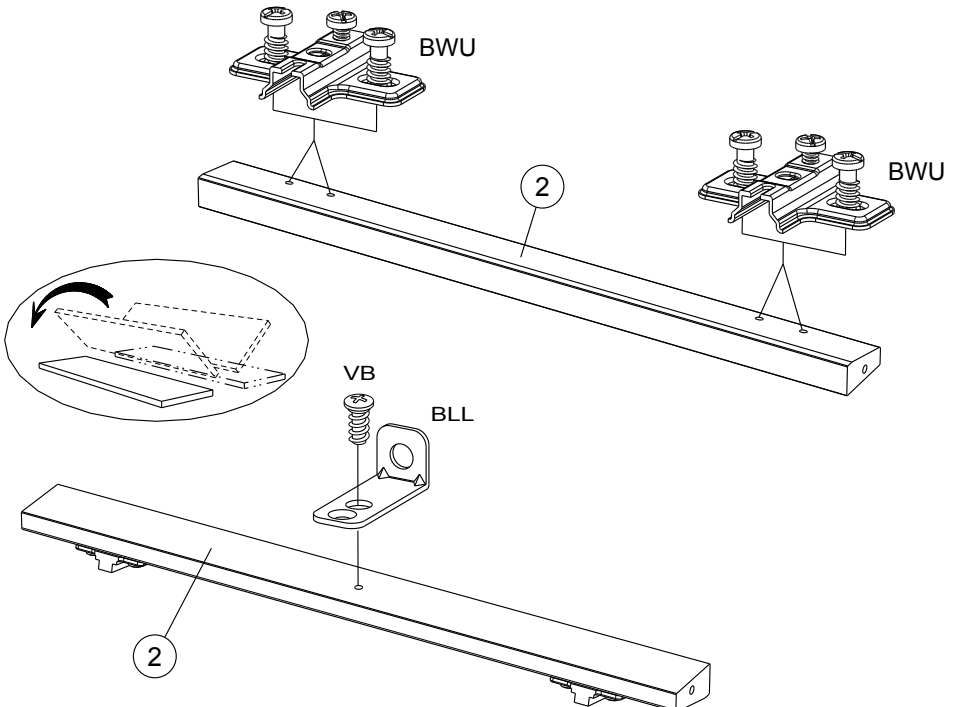

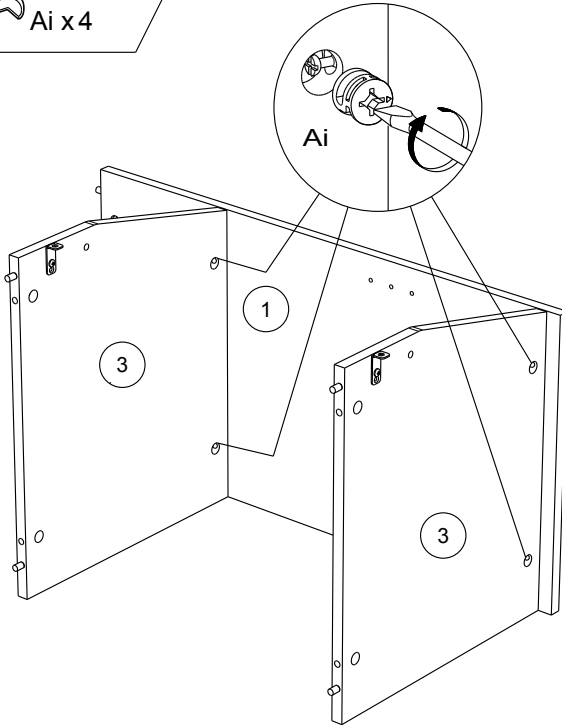
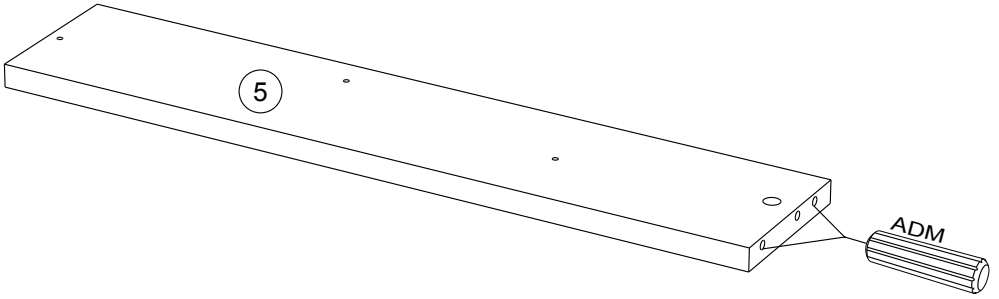
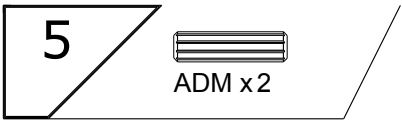



7

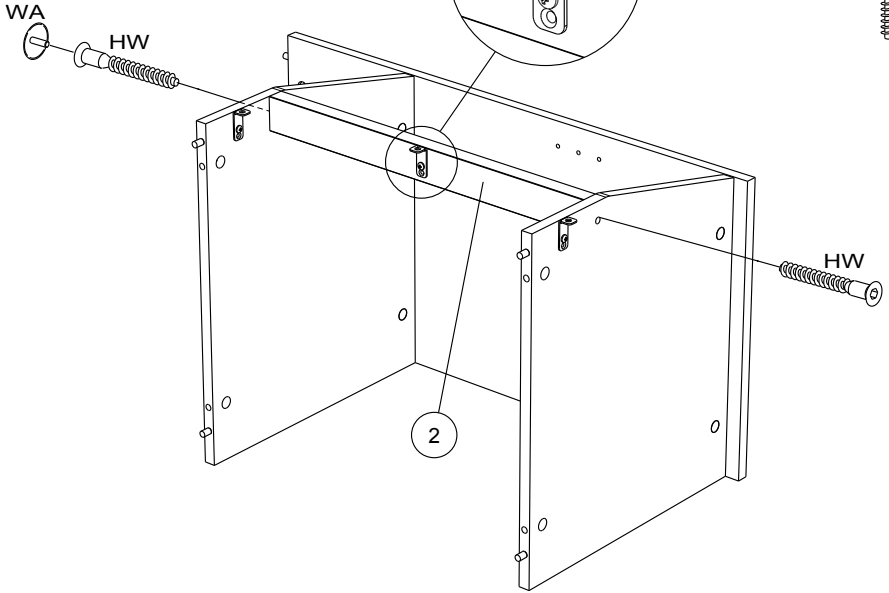
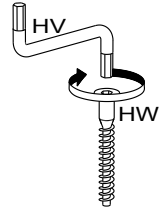
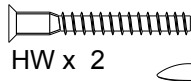
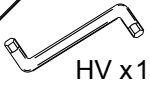

8

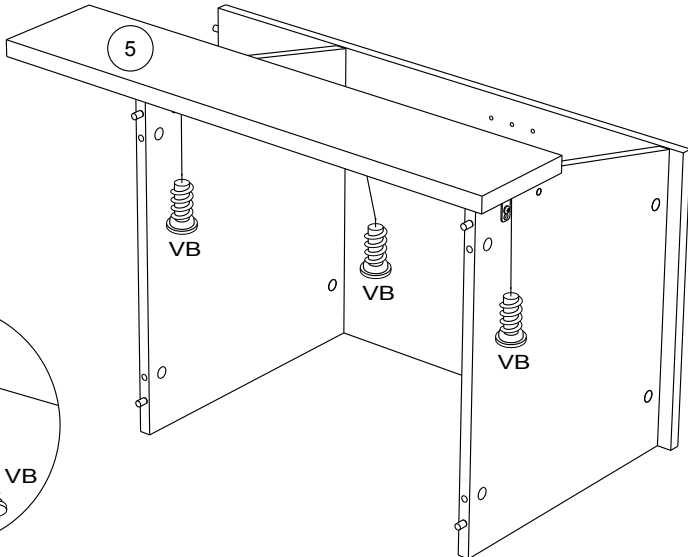
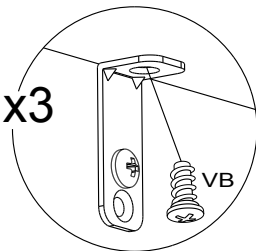

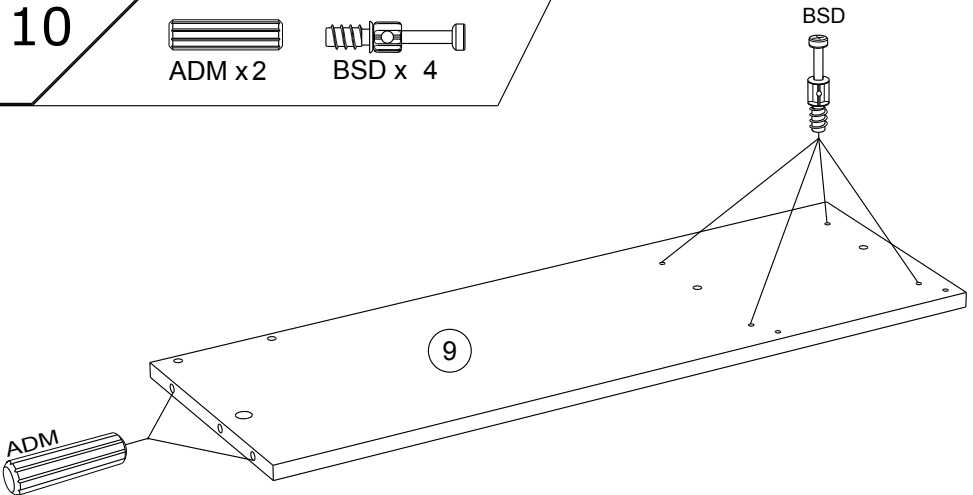
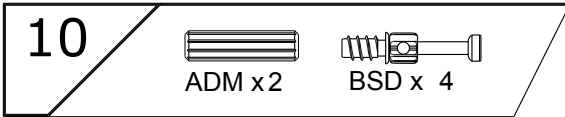
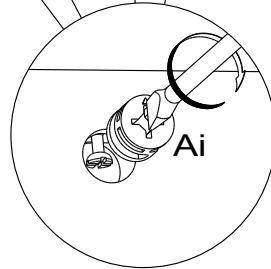
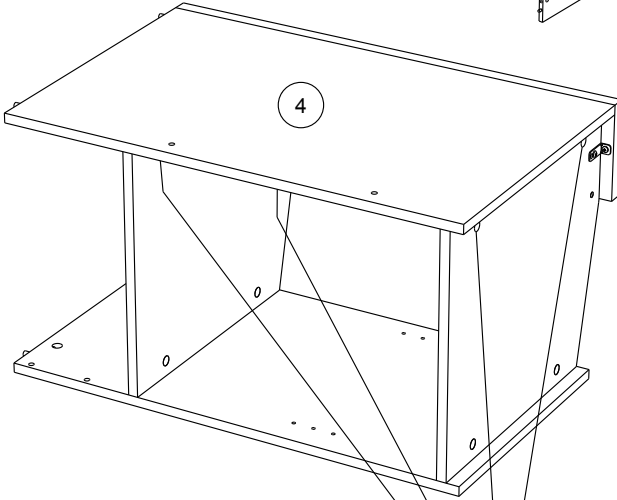
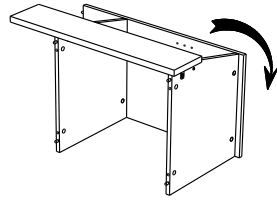

11



ADM x 6



BXC x 1

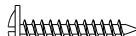

XN x 1

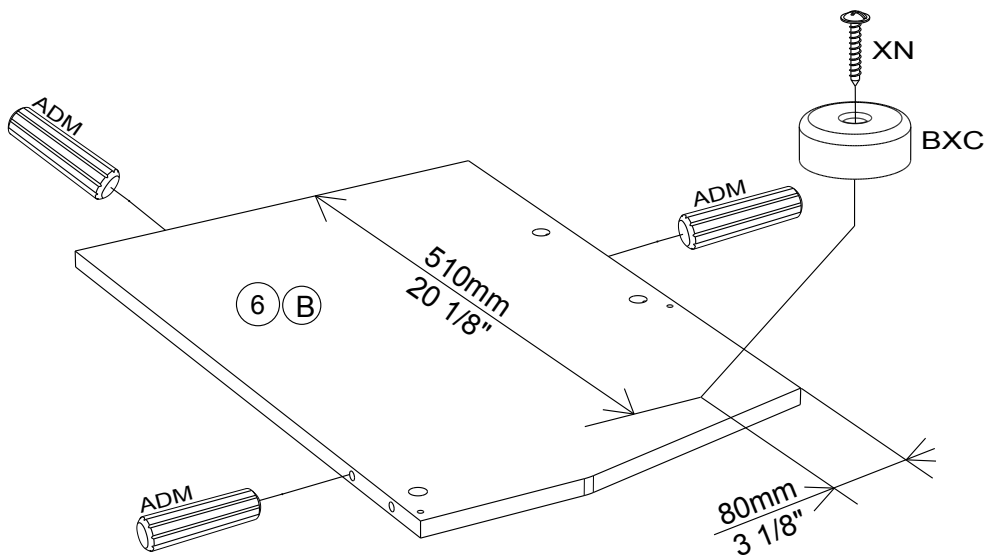
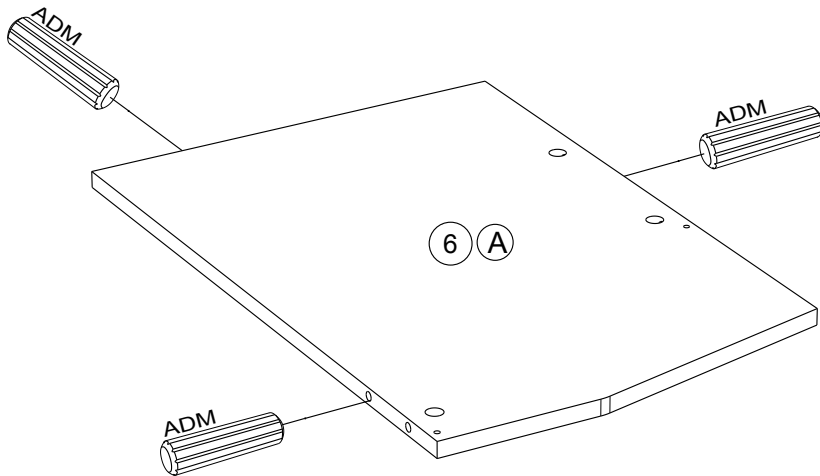

12

ADM x 4

BSD x 2

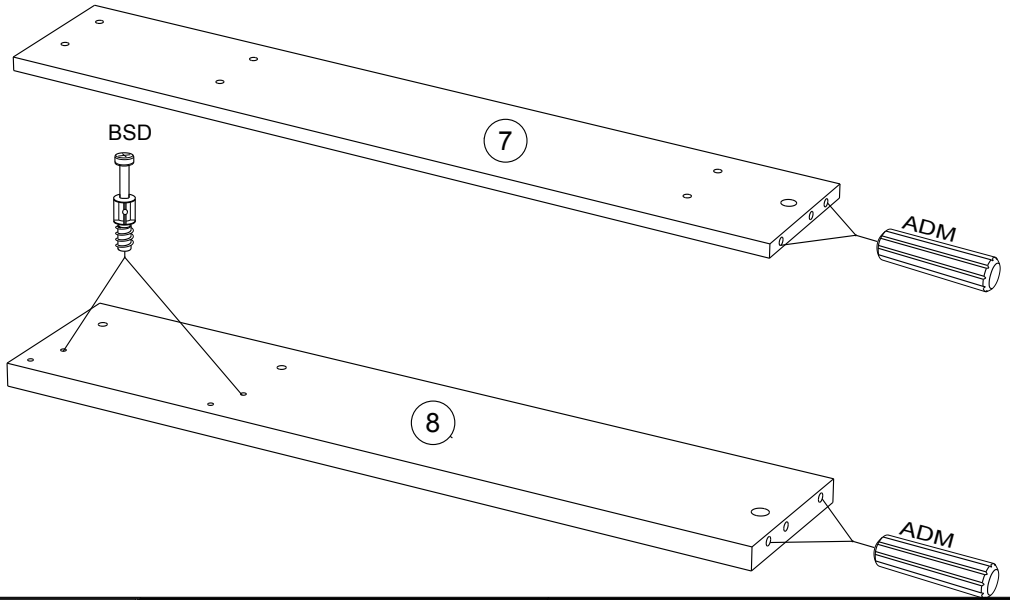

13



Ai x 2



BAG x 1



VB x 1

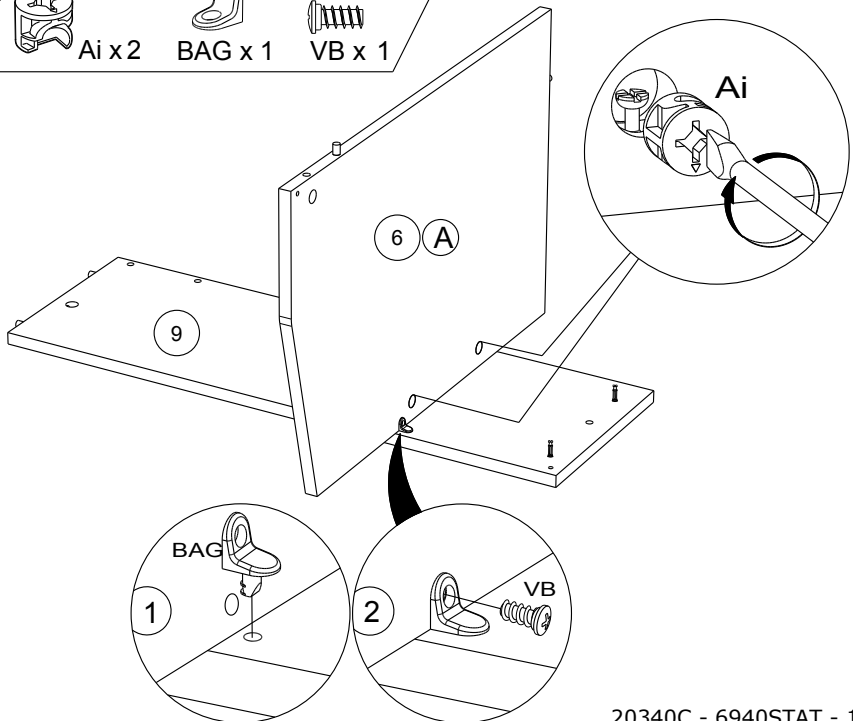

14

BAG x 1

Ai x 2

VB x 1

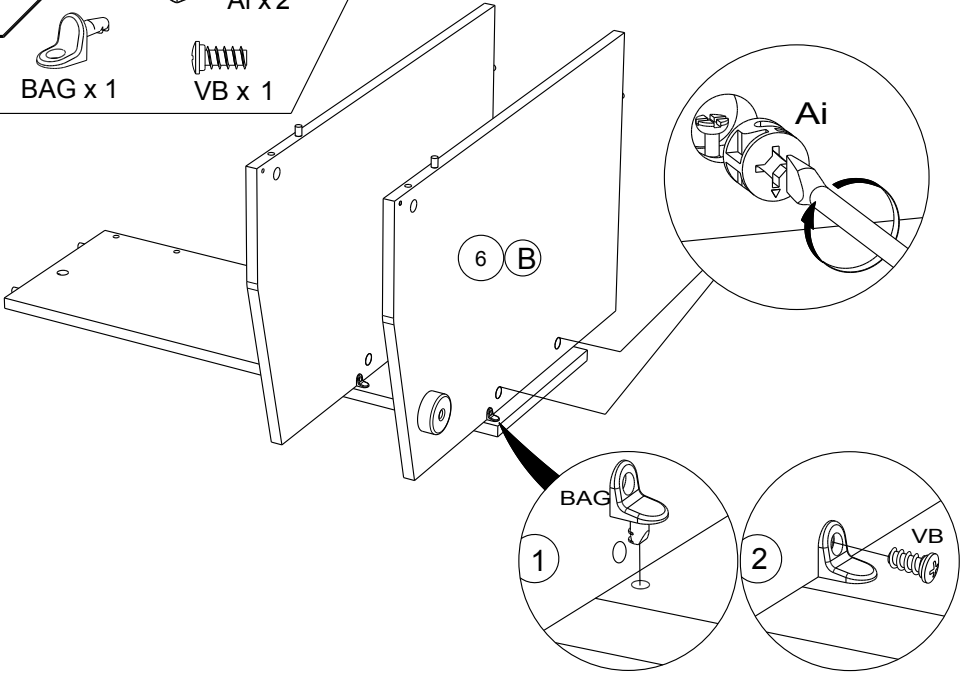

15

Ai x 2

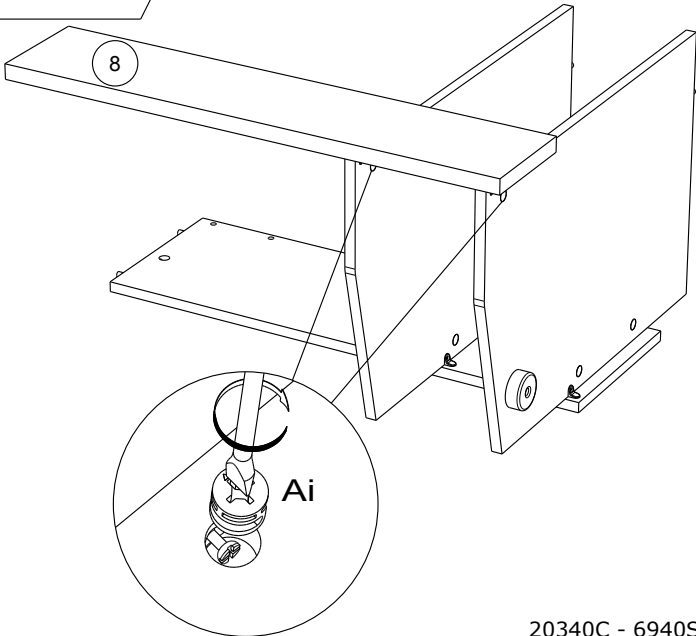

16

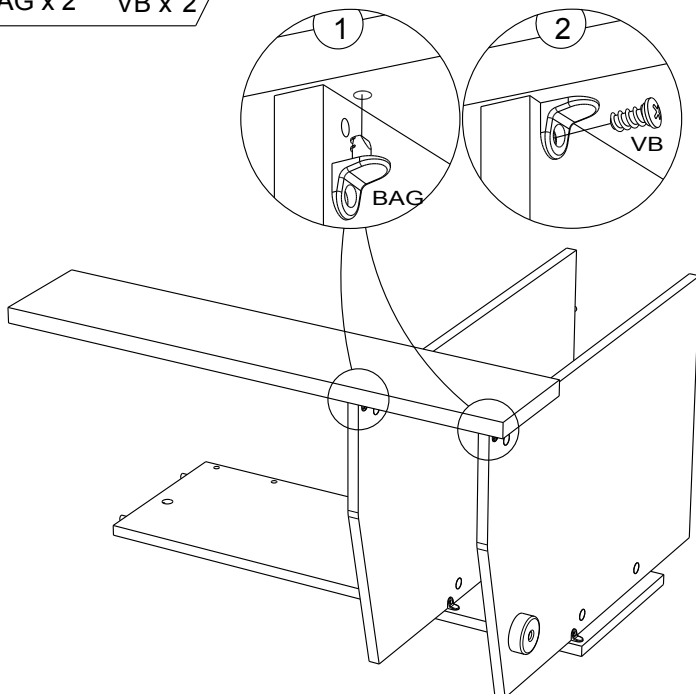

17

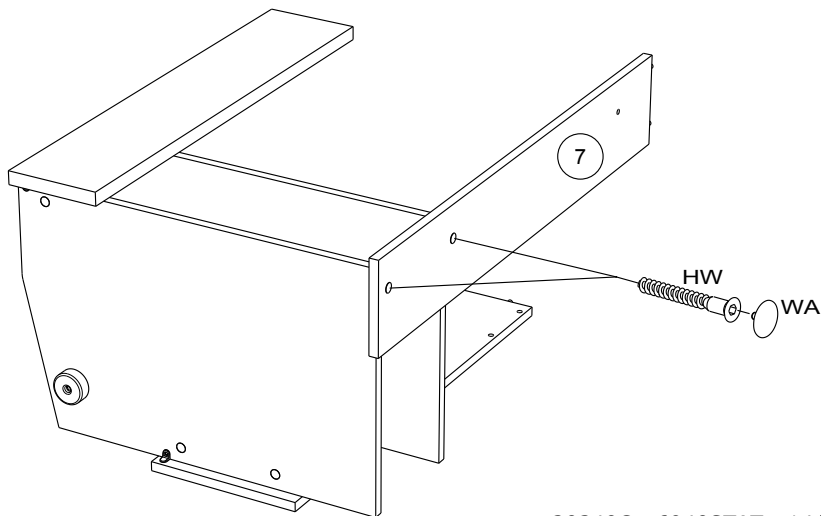
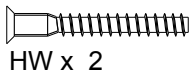

18

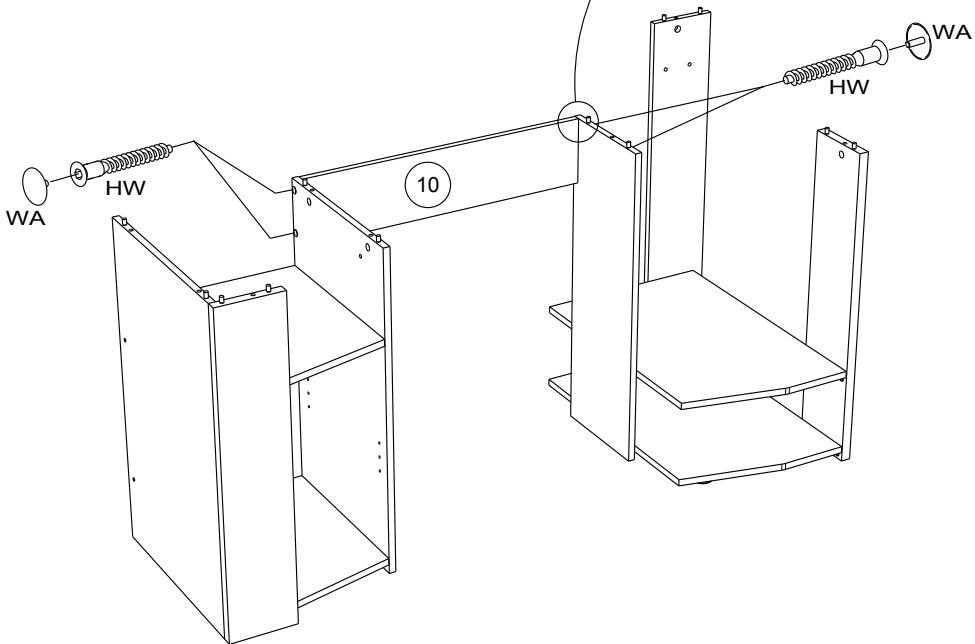
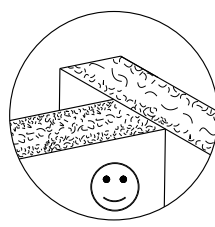
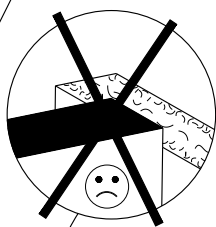
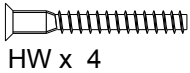

19

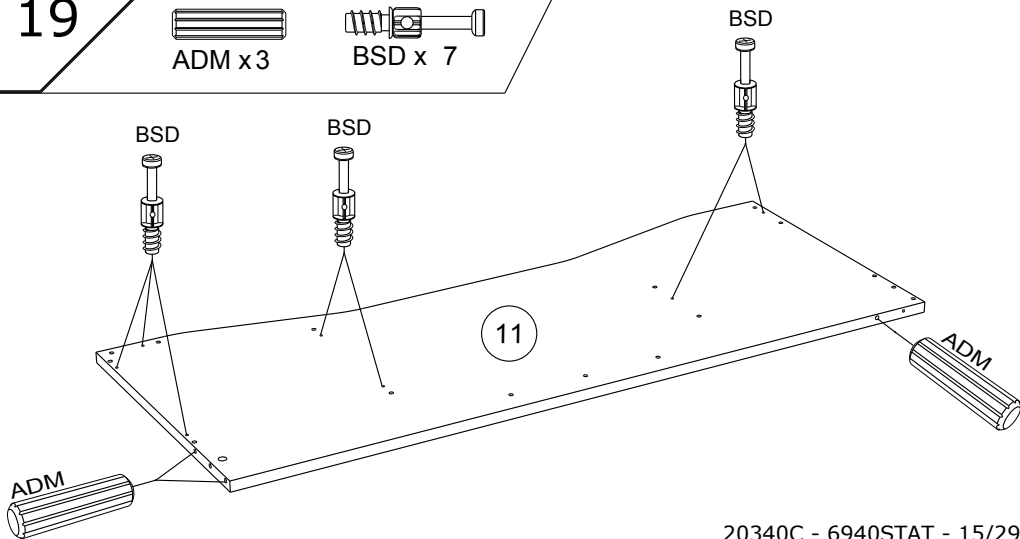
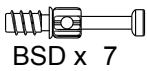

20

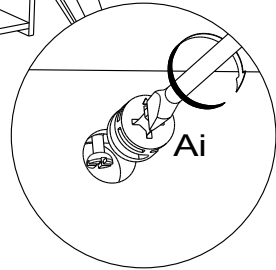
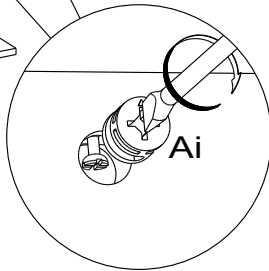
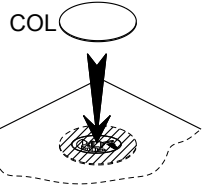
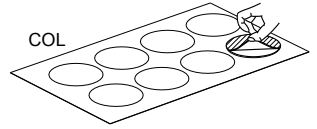
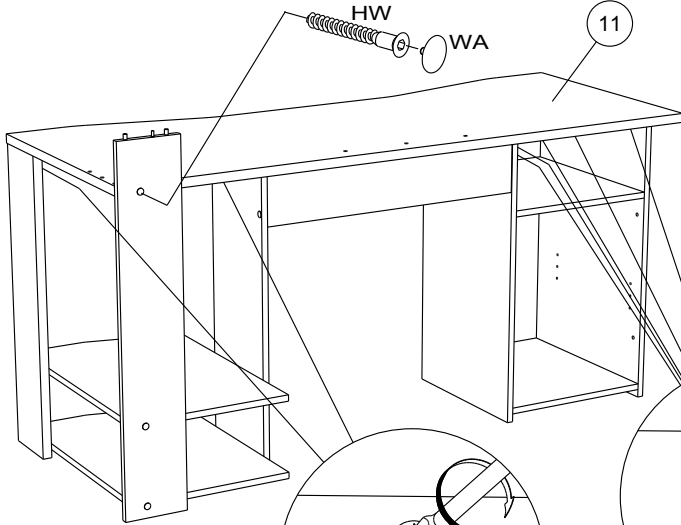
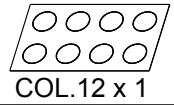
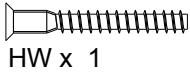

21

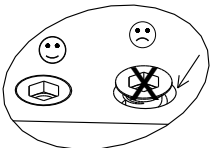
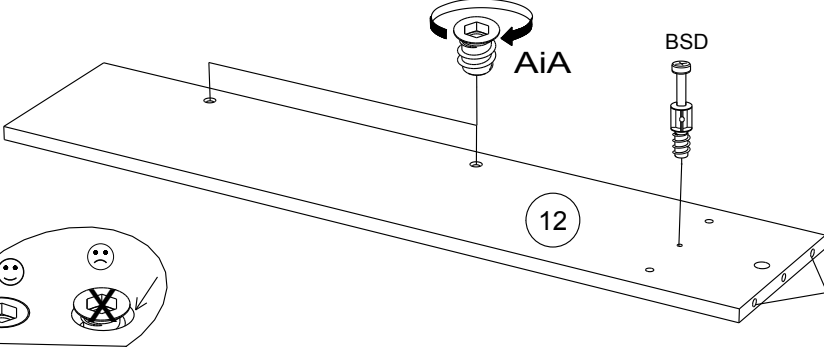
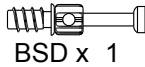

BSD

12

ADM



22

BNU x 2

Ai x 1

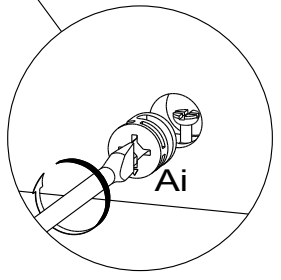
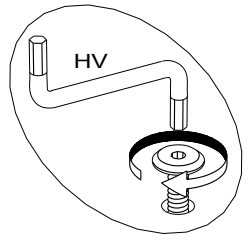
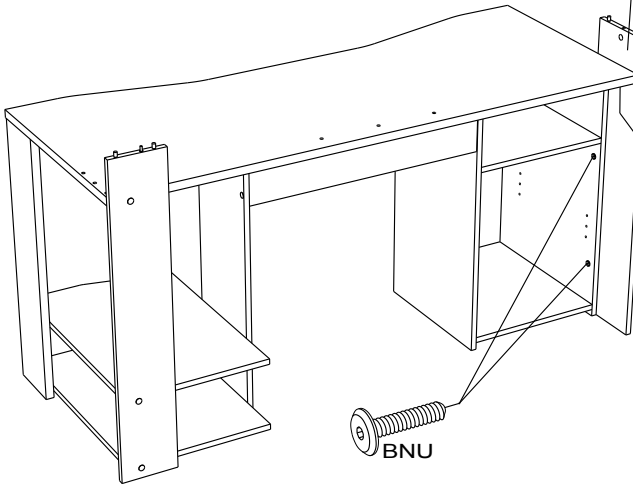

23

YB x 12

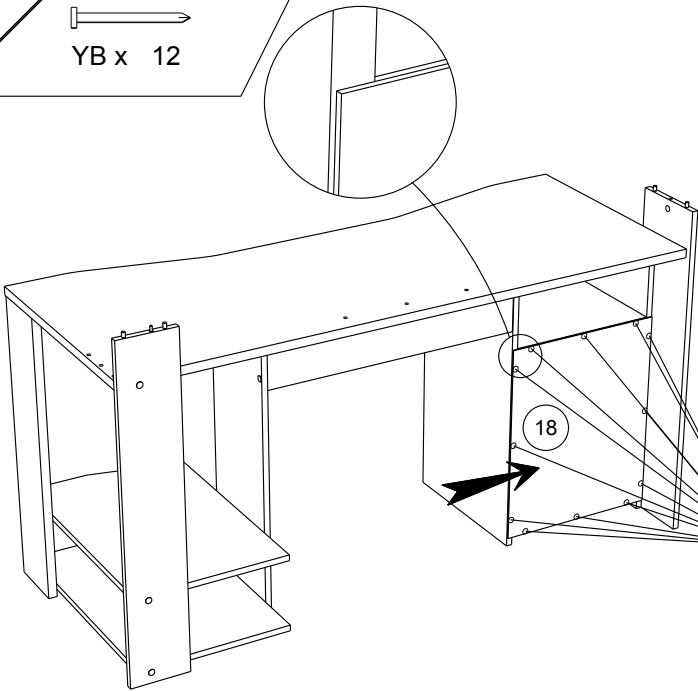

24

ADM x 5

BLL x 2

VB x 2

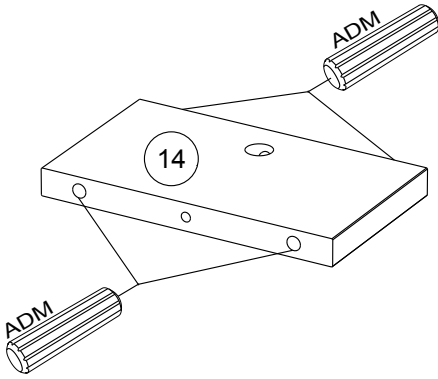
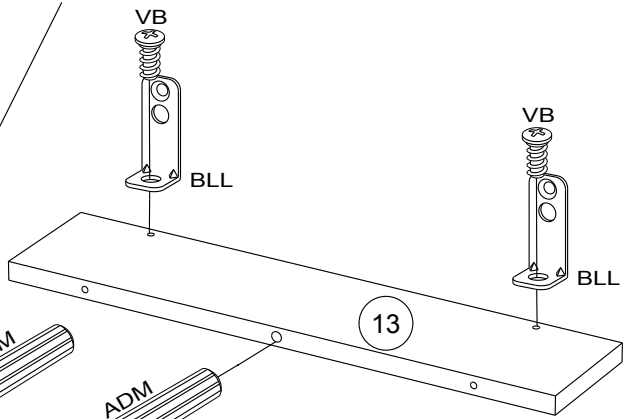

25

Ai x 1

COL.12 x 1

BSD x 3

VB x 2

BSD

BSD

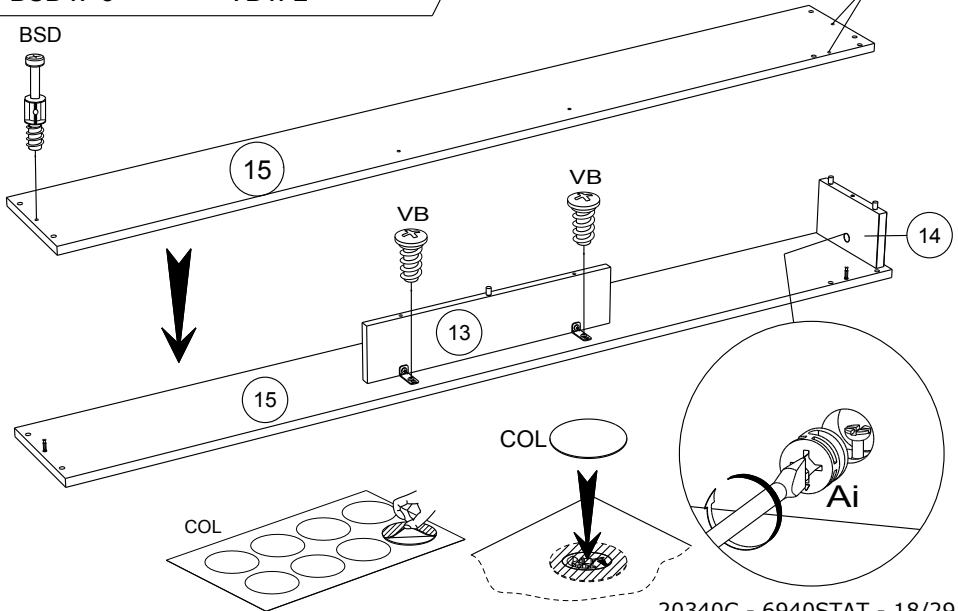

26

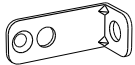

BLL x2



VG x2

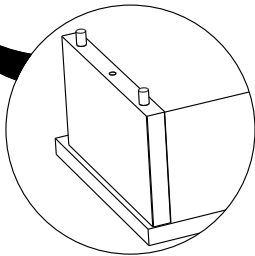
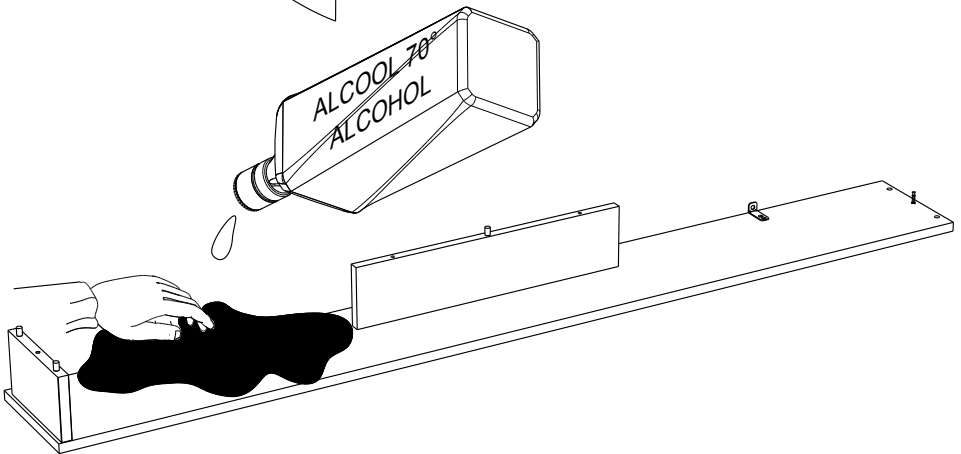
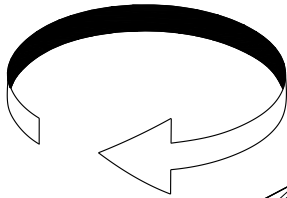
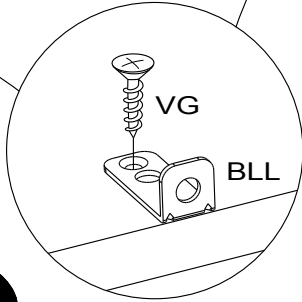
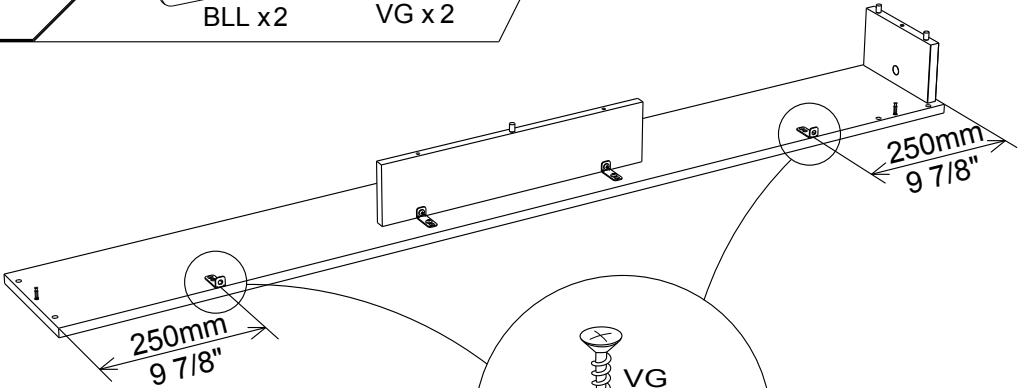

27

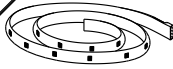

CPH x 1

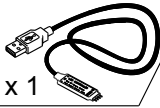

CPI x 1

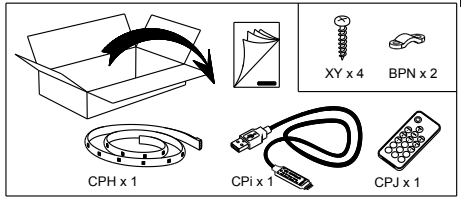

# HOW TO USE



zQ6Jy5YM8\_U

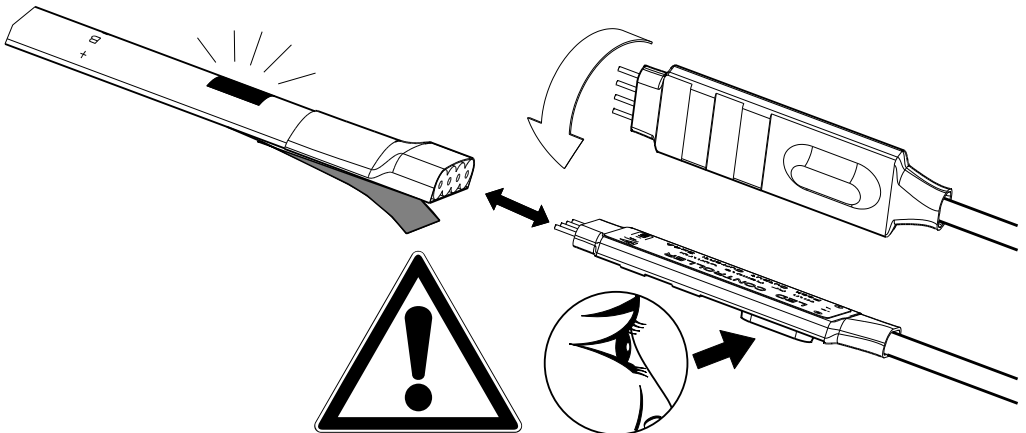
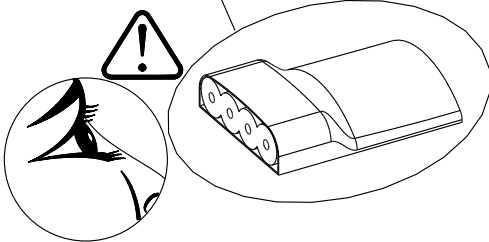
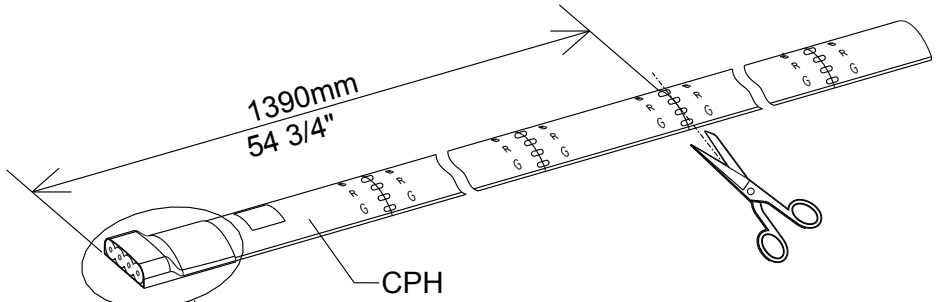

28



BPN x 2



XY x 4

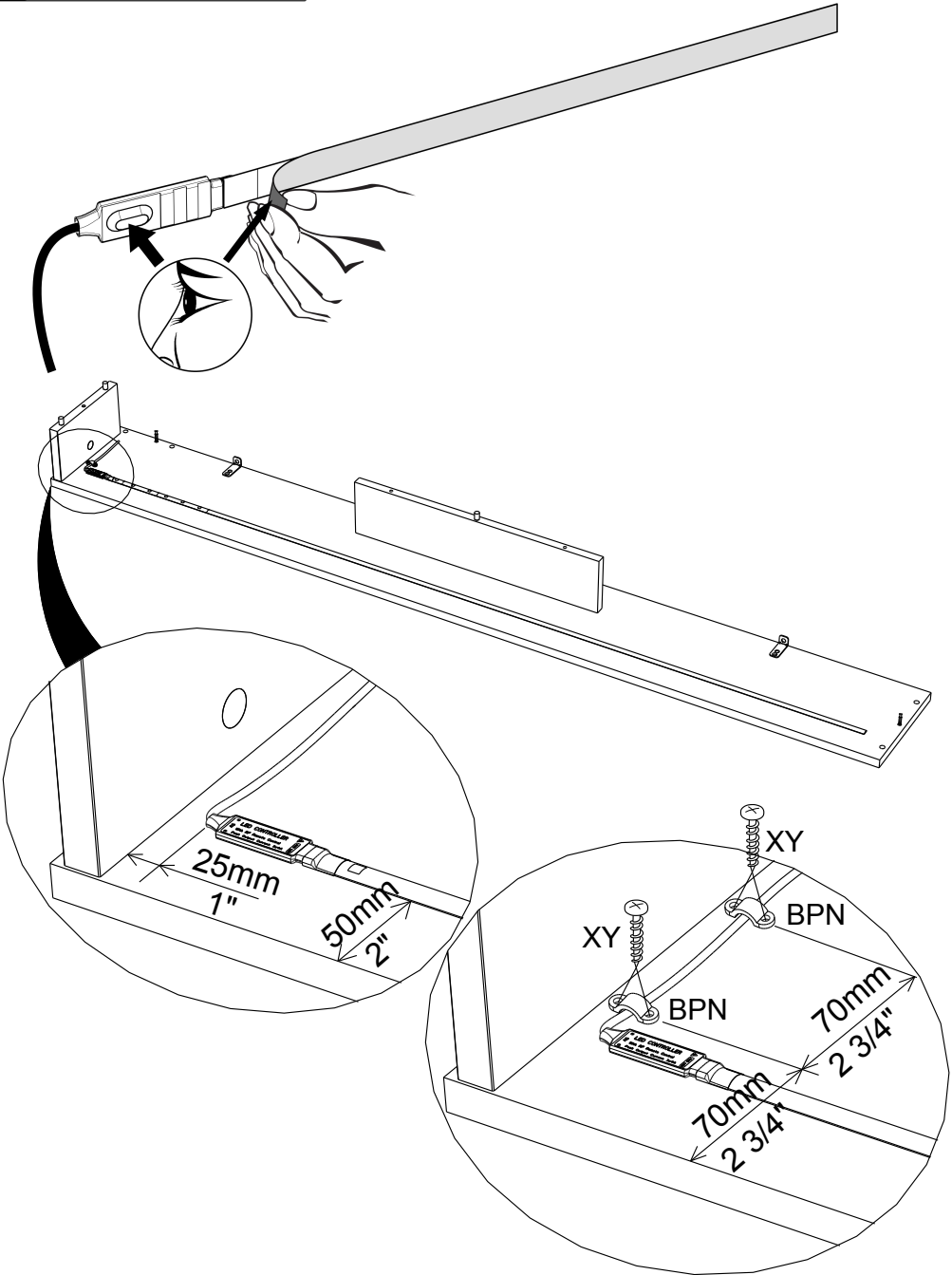

29

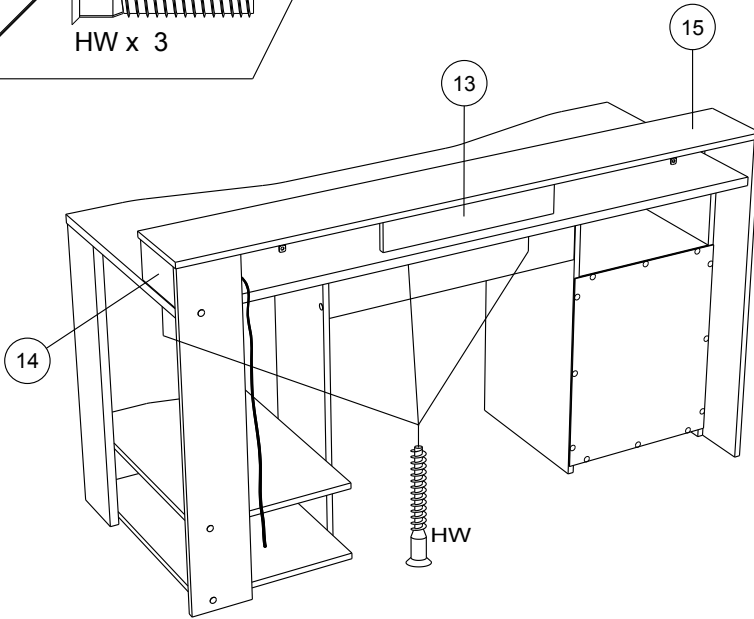
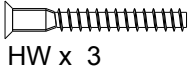

30



Ai x 2

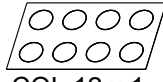

COL.12 x 1

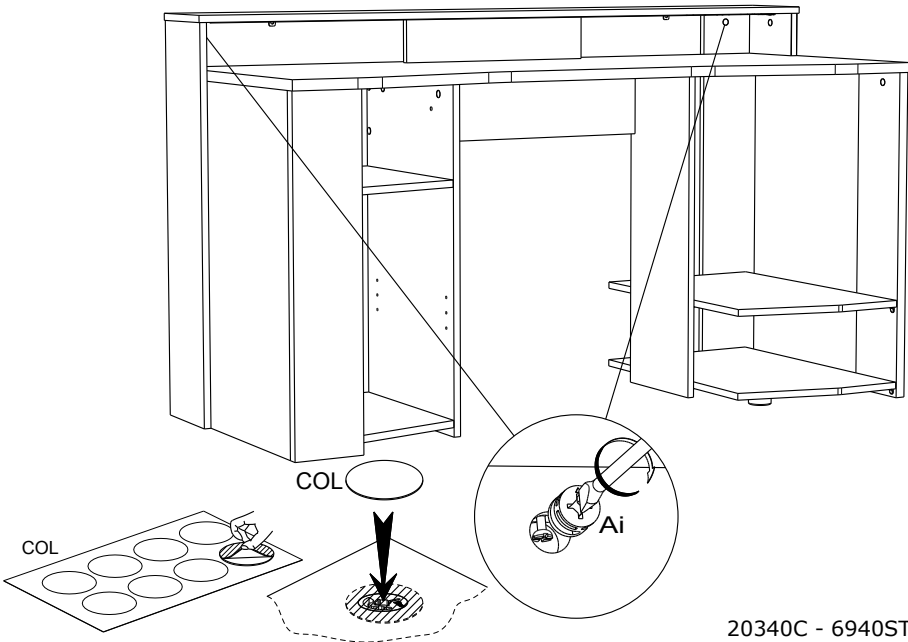

31



BWD x 4

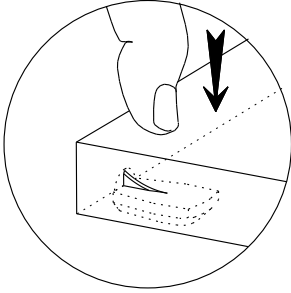
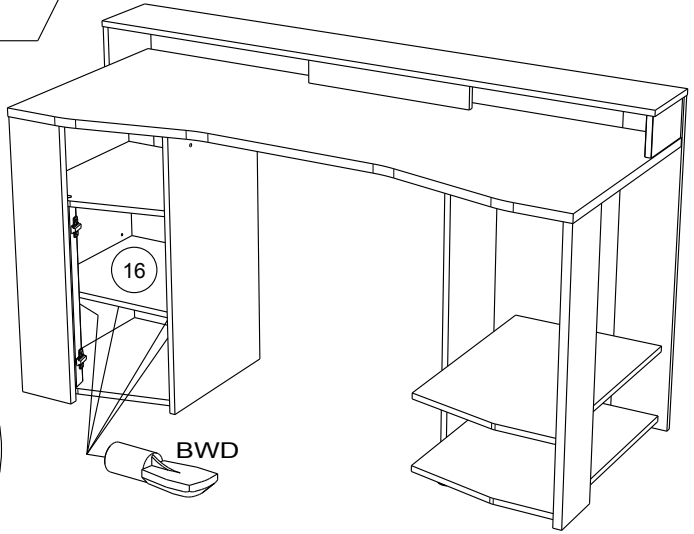

32



BNU x 1

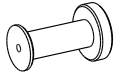

CRV x1

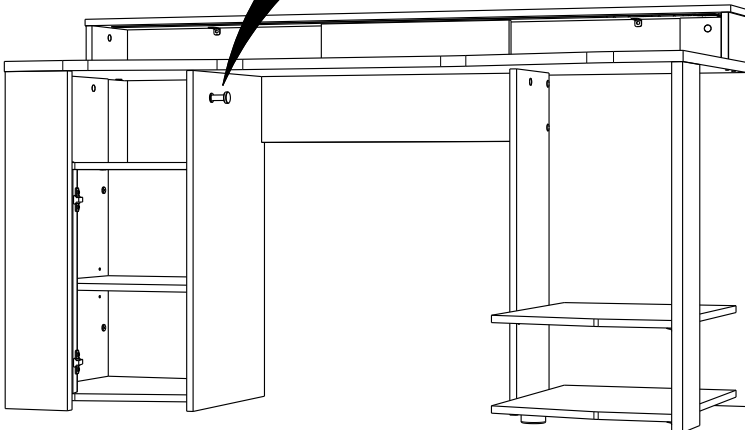
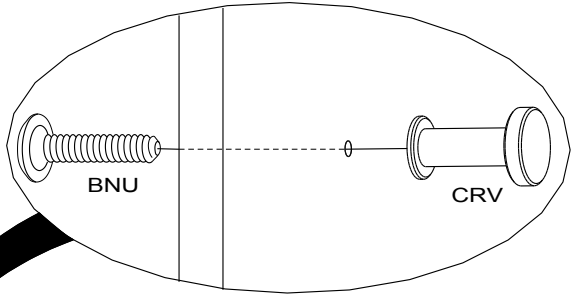

33

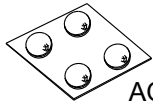

AQO x 1

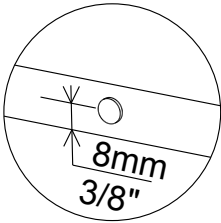
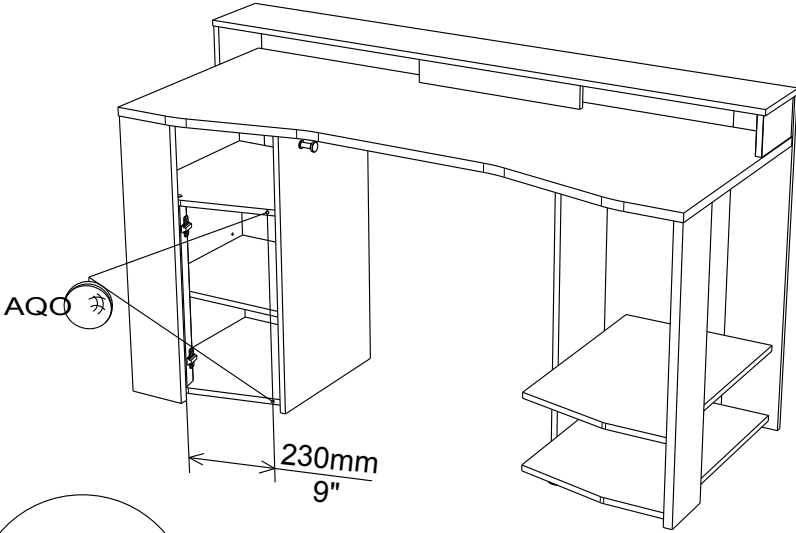

34

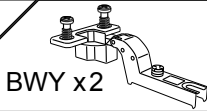

BWY x 2

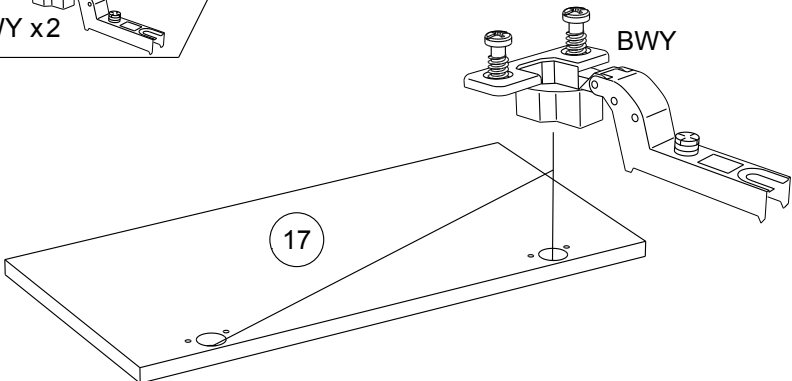



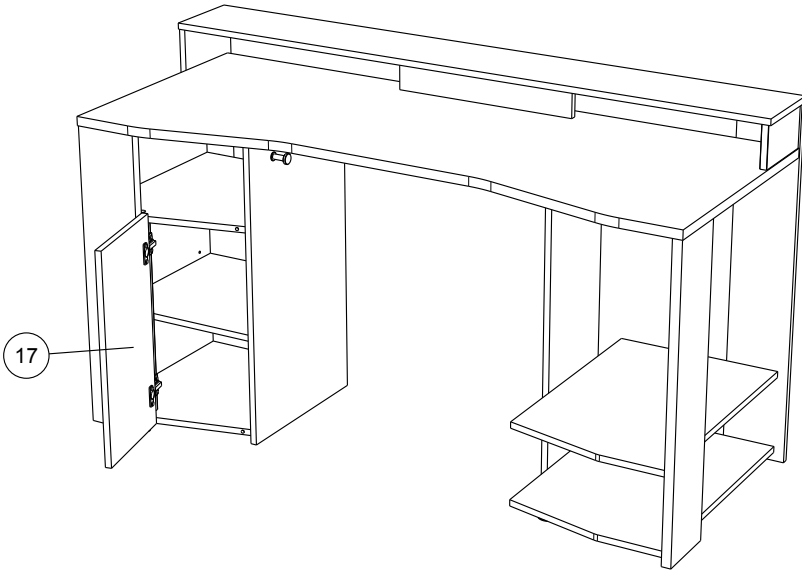

RCH-N

**MONTAGE**

- (GB) LEAFLET
- (D) AUFBAUANLEITUNG
- (E) MONTAJE
- (P) MONTAGEM
- (I) MONTAGGIO
- (NL) MONTAGE

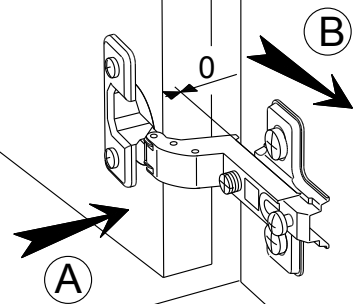

REGLAGE (GB) ADJUSTING (E) AJUSTER (I) AGGIUSTAMENTO  
 (D) ANPASSUNG (P) REGULACAO (NL) AFSTELLING

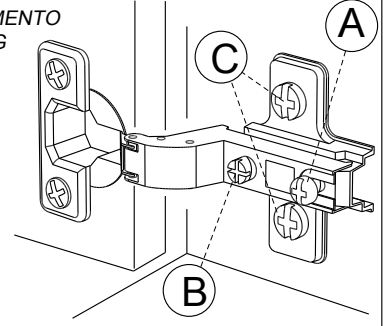
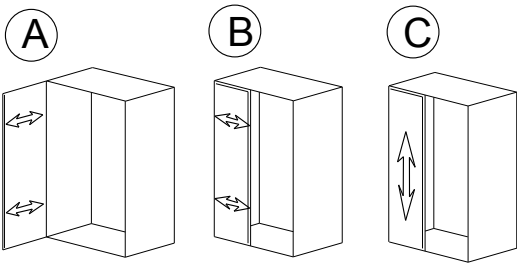

- FR OBLIGATOIRE:** Pour votre sécurité, fixation du meuble au mur.  
Attention, la fixation doit être réalisée par une personne compétente car cela nécessite des chevilles adaptées à la nature de votre mur.
- EN OBLIGATORY:** For your safety, due to risk of overturning, this product must be used with the wall attachment device provided, this should be carried out by a competent person.
- DE OBLIGATORISCH:** Zu Ihrer Sicherheit, befestigen Sie das Möbel an der Wand.  
Achtung: Diese Befestigung ist durch eine fachlich kompetente Person vorzunehmen.  
Hierfür sind für die Bauweise Ihrer Wand geeignete Dübel einzusetzen.
- ES OBLIGATORIO:** Por su seguridad, fijar el mueble a la pared.  
Advertencia: la fijación la ha de llevar a cabo por personal adecuado, ya que requiere el uso de tacos que se adapten al tipo de pared.
- PT OBRIGATÓRIO:** Para sua segurança, fixação do móvel ao muro.  
Atenção: a fixação deverá ser efetuada por pessoa habilitada, visto que são necessárias cavilhas adaptadas ao tipo de parede.
- IT OBBLIGATORIO:** Avvertenza di sicurezza, il fissaggio del mobile a parete deve essere realizzato da una persona competente, in quanto l'operazione richiede l'impiego di tasselli adatti alla natura del muro.
- NL VERPLICHT:** Voor uw veiligheid, bevestiging van het meubel aan de muur.  
Opgelet de bevestiging moet worden uitgevoerd door een bekwaam persoon daar dit voor uw type muur geschikte pluggen vereist.
- CZ POVINNÝ:** Z bezpečnostních důvodů, upevněte nábytek do zdi.  
Pozor, upevnění je třeba svěřit kompetentní osobě, neboť vyžaduje hmoždinky vhodné pro vaši zeď.
- HU KÖTELEZŐ:** Az Ön biztonságá érdekében, a bútor falra rögzítése.  
Figyelmeztetés: a rögzítés csak megfelelő szakképesítéssel rendelkező személy által végezhető el, mert a rögzítéshez a falnak megfelelő csavarokra van szükség.
- PL OBOWIĄZKOWY:** Dla bezpieczeństwa, mocowanie mebla do ściany.  
Uwaga, mocowanie musi zostać wykonane przez osobę kompetentną, ponieważ wymaga to zastosowania kółków dostosowanych do rodzaju ściany.
- RO OBLIGATORIU:** Pentru securitatea dumneavoastră, fixarea mobilierului de perete.  
Atenție, fixarea trebuie să fie realizată de o persoană calificată, deoarece sunt necesare dispozitive de fixare adaptate caracteristicilor peretelui dumneavoastră
- RU ОБЯЗАТЕЛЬНЫЙ :** Для вашей безопасности Крепление мебели к стене  
Внимание! Крепление должно производиться опытным специалистом, т.к. для такой установки потребуются штифты, соответствующие типу вашей стены.
- SK POVINNÉ:** Z bezpečnostných dôvodov, nábytok upevnite k stene.  
Dbajte na to, aby upevnenie vykonala kompetentná osoba, pretože pri upevňovaní sa vyžadujú kolíky vhodné do materiálu, z ktorého je stena vyrobená.
- SL OBVEZNO:** Za vašo varnost, Enota naj bo pritrjena na steno. Pozor: To naj stori kompetentna oseba, ker je potrebno uporabiti pravilni nosilec glede na vrsto stene ki jo uporabljate.
- TR ZORUNLU:** Güvenliğiniz için, Mobilyanın duvara sabitlenmesi  
Dikkat, sabitleme işlemleri uzman biri tarafından yapılmalıdır çünkü bu işlem için duvarınızın malzemesine uygun dübellerin kullanılması gerekmektedir
- EL ΥΠΟΧΡΕΩΤΙΚΟΣ :** Για την ασφάλειά σας στερέωση των επίπλων στον τοίχο.  
Προσοχή, η στερέωση πρέπει να γίνεται από ικανό άτομο, καθώς απαιτούνται σφήνες προσαρμοσμένες στη φύση του τοίχου σας.

**AR واجب :** لسلامتك الشخصية, تثبيت قطعة الأثاث على الحائط

تحذير، يجب أن يقوم شخص متخصص بعملية التثبيت على الحائط إذ أنها تتطلب اسفينا معيناً يتوافق مع طبيعة الحائط نفسه.

**ZH 義務性 :** 为了您的安全，本产品必须靠墙安装。

NB 本产品必须由专业人士安装，且您必须使用符合您的墙壁类型的罗威纤维管。

36

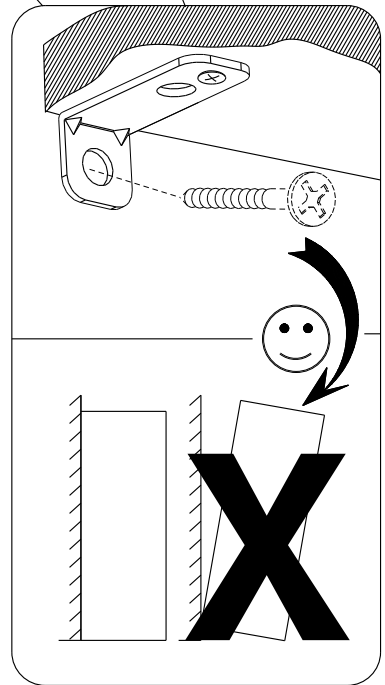
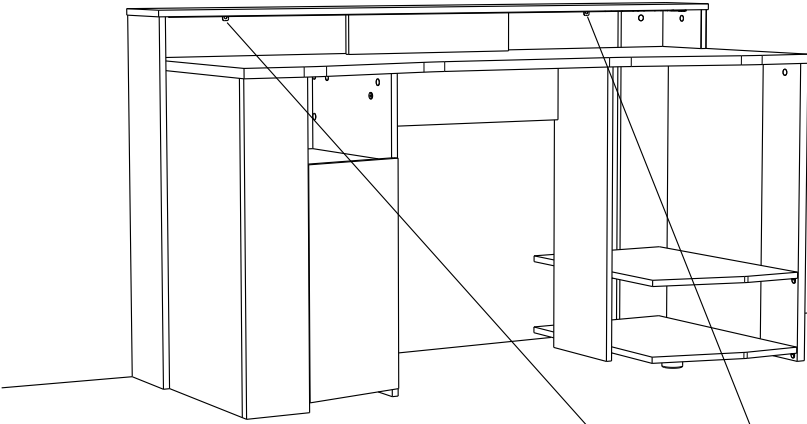

x1

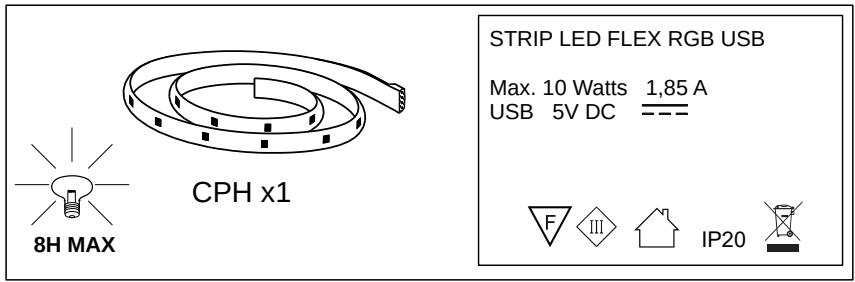

Max. 10W – 1,85A

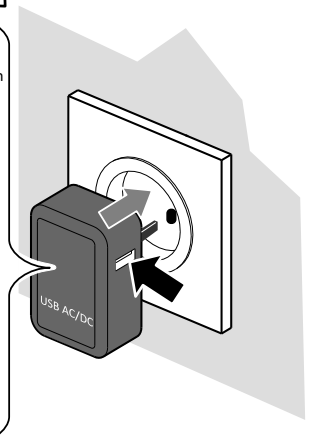
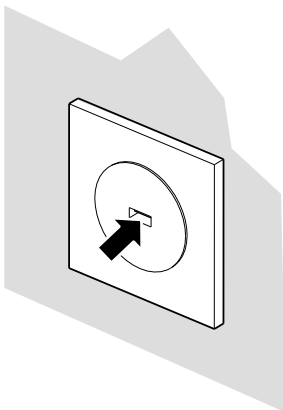
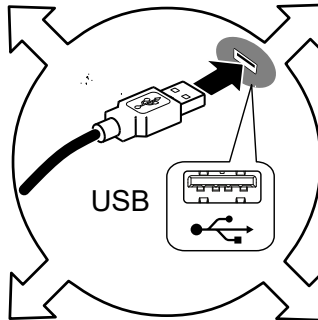
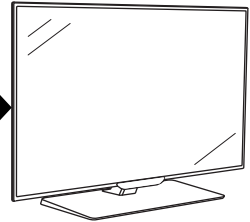
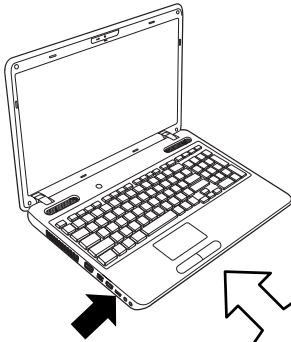

- FR Non inclus
- EN Not included
- DE Nicht im Lieferumfang enthalten
- ES No incluido
- PT Não incluído
- IT Non incluso
- NL Niet inbegrepen
- RU Не включительно
- PL Nie wliczone
- SK Nie sú zahrnuté
- CS Není součástí dodávky
- HU Nem tartalmazza
- RO Nu sunt incluse
- TR Dahil değil
- EL δεν περιλαμβάνονται
- SL Ni vključeno
- ZH 不包含
- AR غير المدرجة

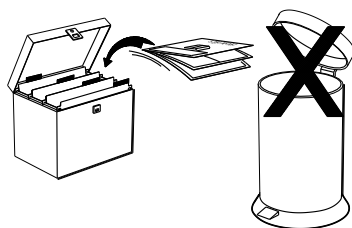
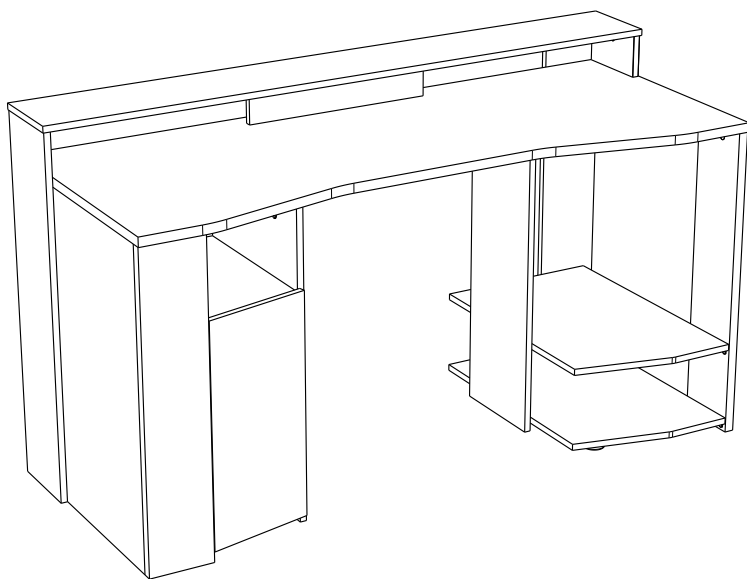

Faites un geste pour l'environnement en triant vos déchets d'emballage  
Make a gesture for the environment by sorting out your waste of packaging  
Machen Sie eine Bewegung für die Umwelt, ihre Verpackungsabfälle sortierend  
Haga un gesto para el medio ambiente escogiendo sus residuos de embalaje  
Pensate all'ambiente riciclando i vostri rifiuti di imballaggio  
Naredite uslugo okolju in lo ujte odpadke

# 6940BI2P

PARISOT INDUSTRIE 70800 SAINT LOUP SUR SEMOUSE -FRANCE-



## i HOW TO USE

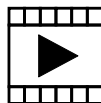

G 🔍 zQ6Jy5YM8\_U

# A

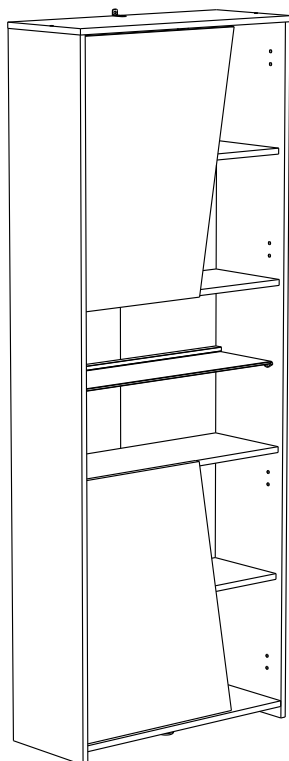

# B

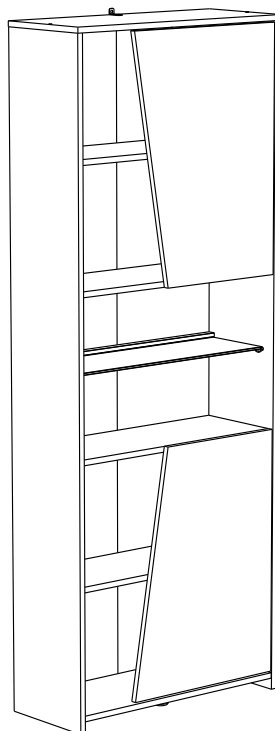

Gamme : GAMING



PARISOT INDUSTRIE

## FR Remerciements :

Nous vous remercions d'avoir choisi un meuble créé et fabriqué par le Groupe Pariset et espérons qu'il vous donnera entière satisfaction.

## EN Thanks:

Thank you for choosing furniture designed and manufactured by the Pariset Group. We hope you are totally satisfied with your purchase.

## DE Danksagung:

Wir danken Ihnen für den Kauf eines Frankreich von der Pariset-Gruppe entwickelten und hergestellten Möbelstücks und hoffen, dass Sie es zu Ihrer vollkommenen Zufriedenheit finden werden.

## HU Köszönet:

Köszönjük, hogy a Pariset Groupe által létrehozott és gyártott bútort választott, reméljük, hogy elégedett lesz a termékkel.

## PT Agradecimentos:

Obrigado por ter escolhido um móvel concebido e fabricado pelo Grupo Pariset, esperando que seja do seu inteiro agrado.

## IT Ringraziamenti:

Grazie per avere scelto un mobile progettato e fabbricato dal Gruppo Pariset. Speriamo soddisfisi appieno le vostre esigenze.

## NL Bedankje:

Wij bedanken u voor de aankoop van een door de Groep Pariset ontworpen en vervaardigd meubel en hopen dat u er veel plezier aan zult beleven.

## CZ Poděkování:

Děkujeme, že jste si vybrali nábytek navržený a vyrobený společností Pariset Group. Doufáme, že budete svým nákupem naprosto spokojeni.

## ES Agradecimientos:

Les damos las gracias por haber elegido un mueble diseñado y fabricado por el Groupe Pariset y esperamos que sea de su total agrado.

## PL Podziękowania:

Dziękujemy za wybór mebli stworzonych i wyprodukowanych przez Grupę Pariset. Mamy nadzieję, że będziecie Państwo w pełni zadowoleni z zakupu.

## RO Mulțumiri:

Vă mulțumim că ați ales un articol de mobilier conceput și fabricat de Grupul Pariset și sperăm că veți fi pe deplin satisfăcuți de acesta.

## RU Благодарность:

Мы благодарим вас за то, что вы выбрали мебель, созданную и произведенную Групп Паризо, и надеемся,

что вы будете полностью удовлетворены нашей продукцией.

## SK Pod'akovanie:

Ďakujeme, že ste si vybrali nábytok navrhnutý a vyrobený spoločnosťou Pariset Group. Dúfame, že budete svojím nákupom absolútne spokojní.

## SL Hvala:

Hvala, ker ste izbrali pohištvo, ki je dizajnirano in proizvedeno s strani Pariset Group. Upamo, da ste maksimalno zadovoljni z vašim nakupom.

## TR Teşekkür ederiz:

Pariset Group tarafından tasarlanan ve üretilen bu mobilyayı seçtiğiniz için teşekkür ederiz. Ürünümüzden memnun kalmanızı ümit ederiz.

## ZH 感谢:

感谢您选择帕里索集团设计制造的家具。我们希望您对此次购买十分满意、

## AR شكر:

نشكركم لاختياركم هذه القطعة من الأثاث من تصميم وتصنيع مجموعة باريزو Pariset ونتفنى أن نتلال رضاءكم.

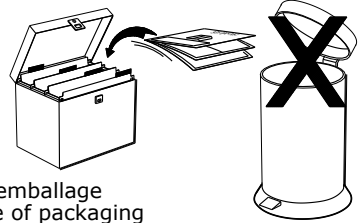

Faites un geste pour l'environnement en triant vos déchets d'emballage  
Make a gesture for the environment by sorting out your waste of packaging  
Machen Sie eine Bewegung für die Umwelt, ihre Verpackungsabfälle sortierend  
Haga un gesto para el medio ambiente escogiendo sus residuos de embalaje  
Pensate all'ambiente riciclando i vostri rifiuti di imballaggio  
Naredite uslugo okolju in lo ujte odpadke

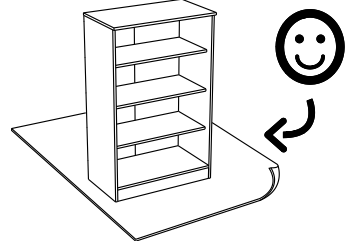
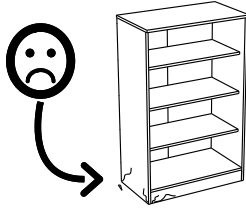
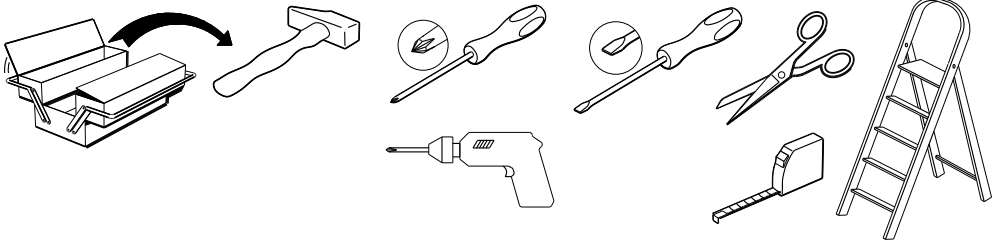

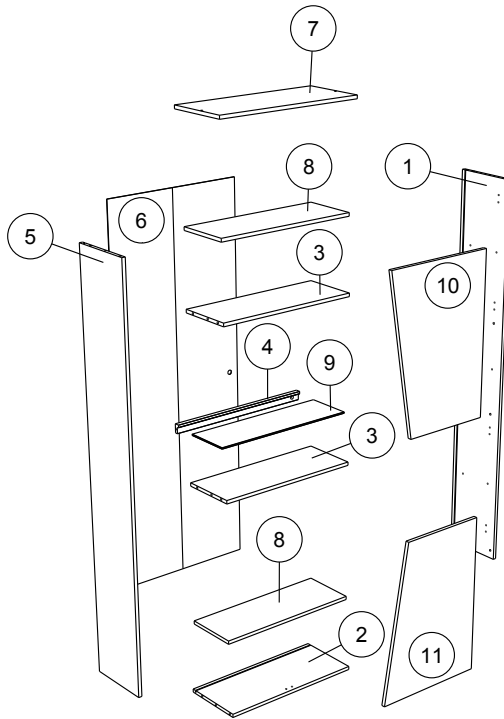
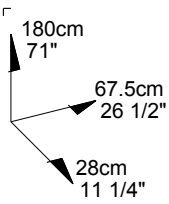

		mm			inch		
④	x 1	638	40	22	25 1/8	1 9/16	7/8
⑧	x 2	639	236	15	25 3/16	9 5/16	9/16
③	x 2	639	241	15	25 3/16	9 1/2	9/16
②	x 1	639	277	15	25 3/16	10 7/8	9/16
⑩	x 1	659	470	15	25 15/16	18 1/2	9/16
⑪	x 1	659	470	15	25 15/16	18 1/2	9/16
⑦	x 1	671	280	15	26 7/16	11	9/16
①	x 1	1785	278	15	70 1/4	10 15/16	9/16
⑤	x 1	1785	278	15	70 1/4	10 15/16	9/16
⑨	x 1	638	199	6	25 1/8	7 13/16	1/4
⑥	x 1	1754	654	3	69 1/16	25 3/4	1/8



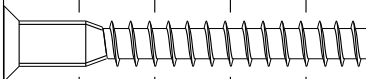
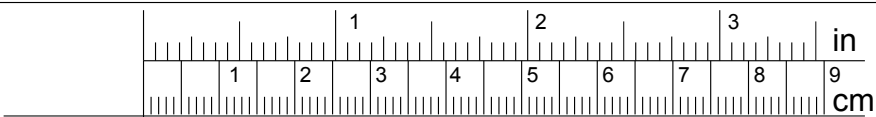
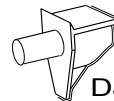
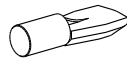
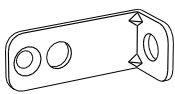
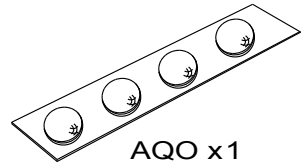
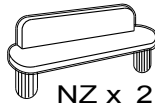
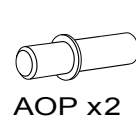
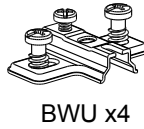
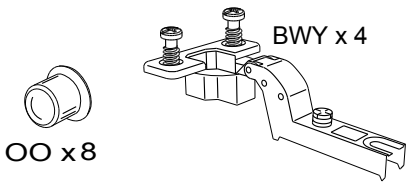

HW x 2

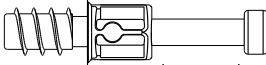

BSD x 6



ADM x 16



ADU x 2

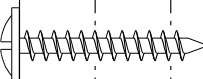

XN x 1

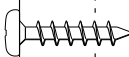

QA x 3

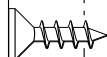

VG x 1

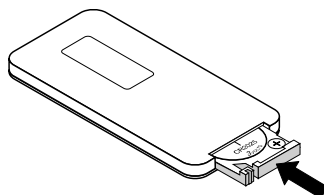
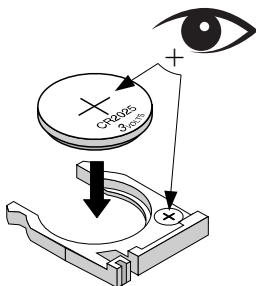
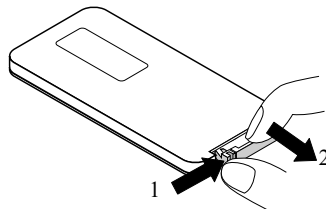
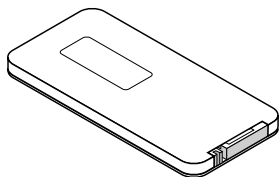
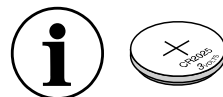
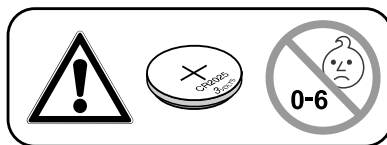
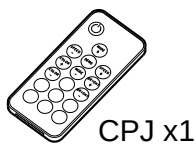
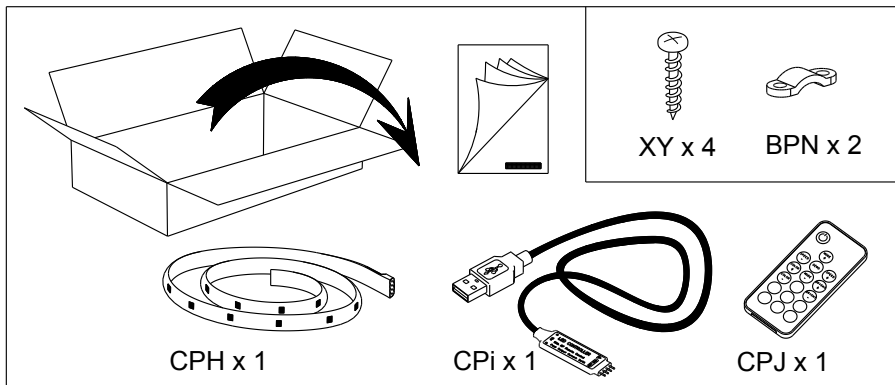

- FR Pile CR2025 non fournie.  
 EN CR2025 battery not included.  
 DE Batterie CR2025 nicht mitgeliefert.  
 ES Pila CR2025 no incluida  
 PT Pilha CR2025 não fornecida.  
 IT Pila CR2025 non fornita.  
 NL Batterij CR2025 niet bijgeleverd.  
 RU Батарейка CR2025 в комплект не входит.  
 PL Bateria CR2025 nie dołączona do zestawu.  
 SK Batéria CR2025 nie je súčasťou balenia.  
 CS CR2025 není součástí dodávky.  
 HU CR2025 akkumulátor nem tartozék.  
 RO Bateria CR2025 nu este inclusă.  
 TR CR2025 pil dahil değildir.  
 EL Η μπαταρία CR2025 δεν παρέχεται.  
 SL CR2025 baterija ni priložena.  
 ZH CR2025 電池不包括在內。  
 AR بطارية CR2025 غير للمدرجة.

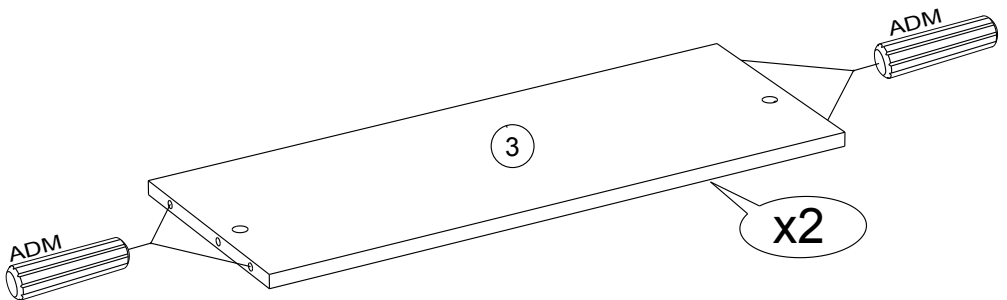
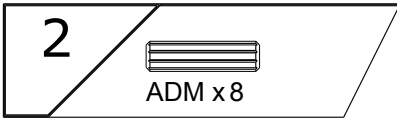
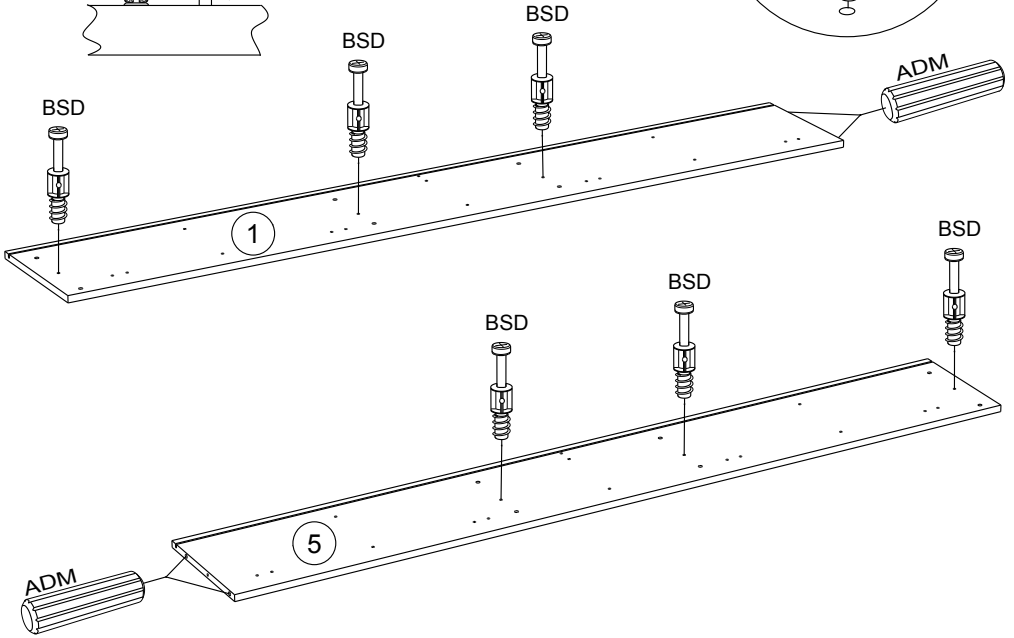
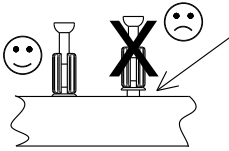
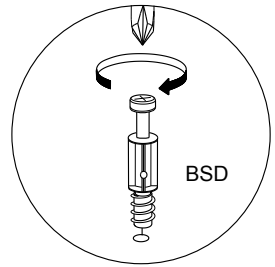
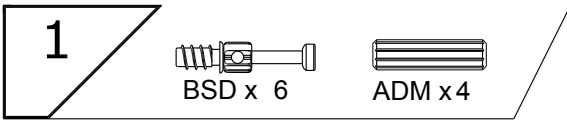

3

ADM x4

NZ x1

BSM x1

XN x 1

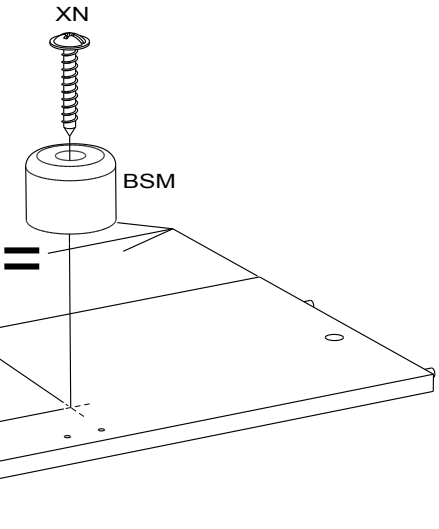
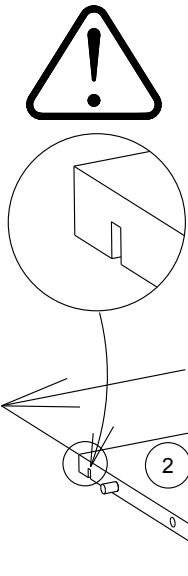
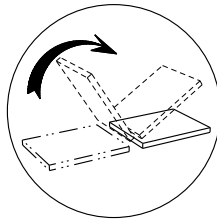
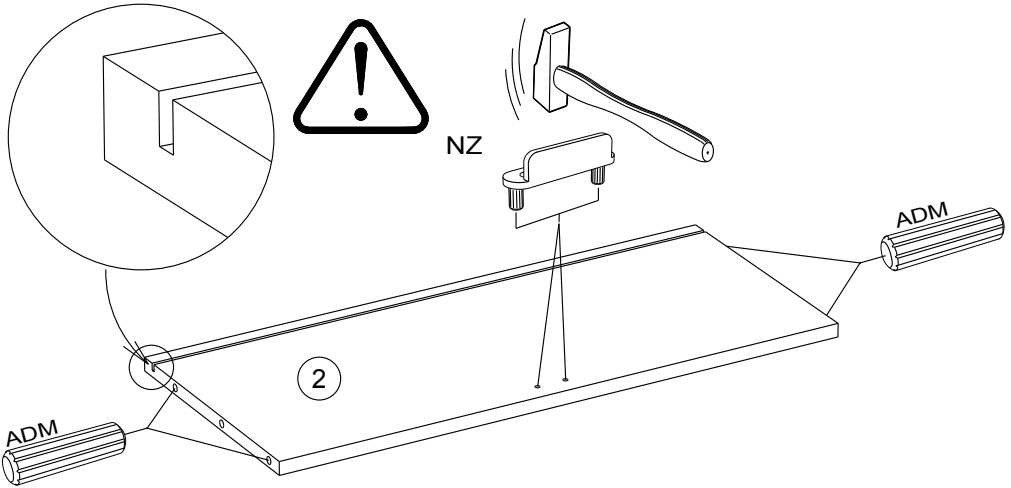

4  
ADU x 2

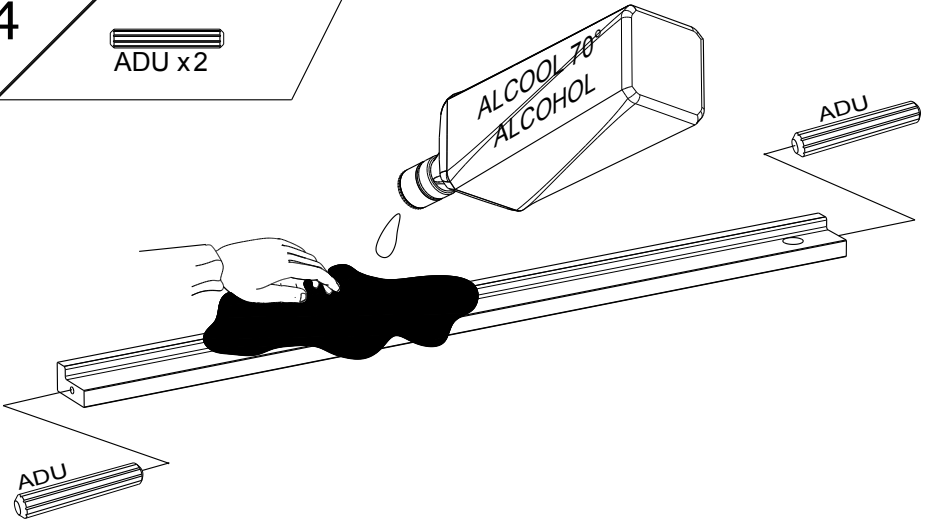

5  
CPH x 1      CPi x 1

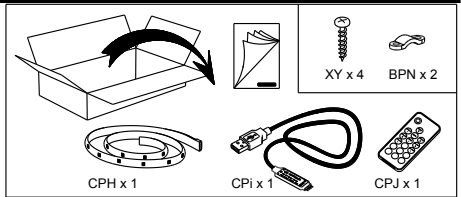

**i HOW TO USE**

**G**

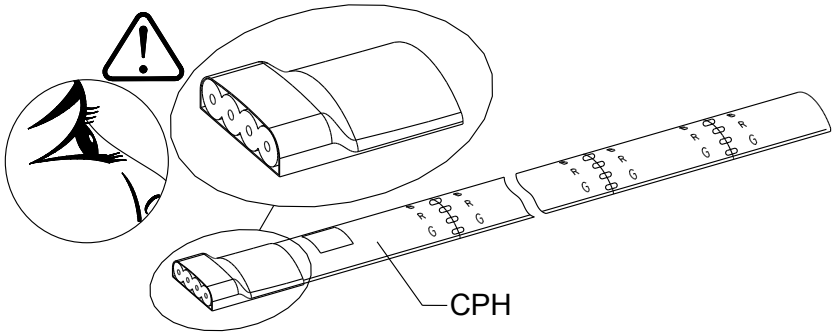

6

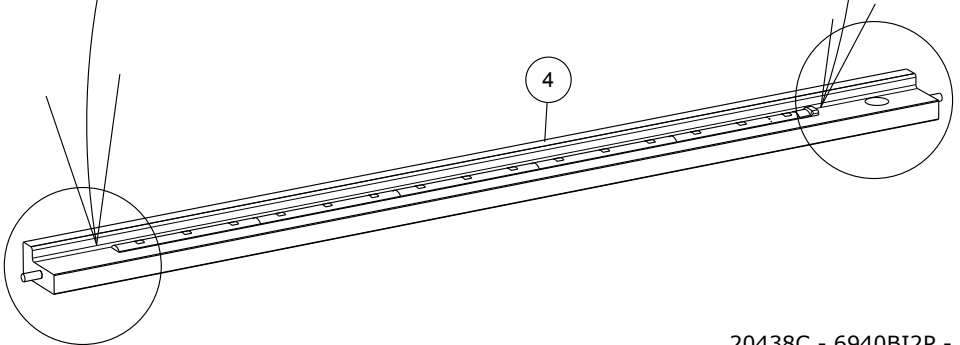
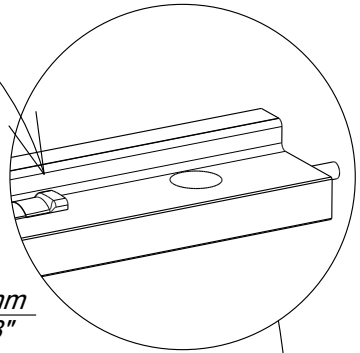
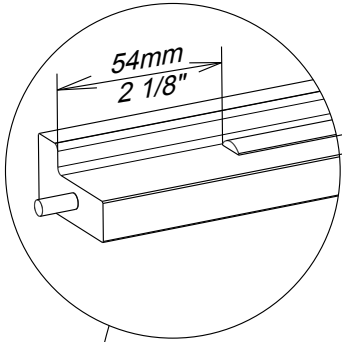
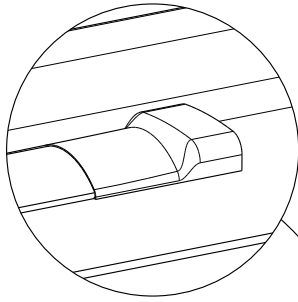
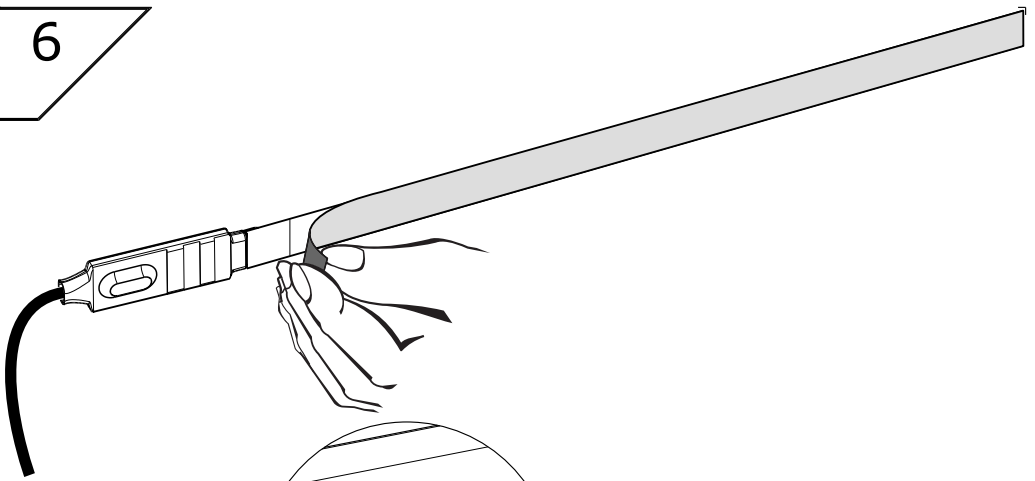

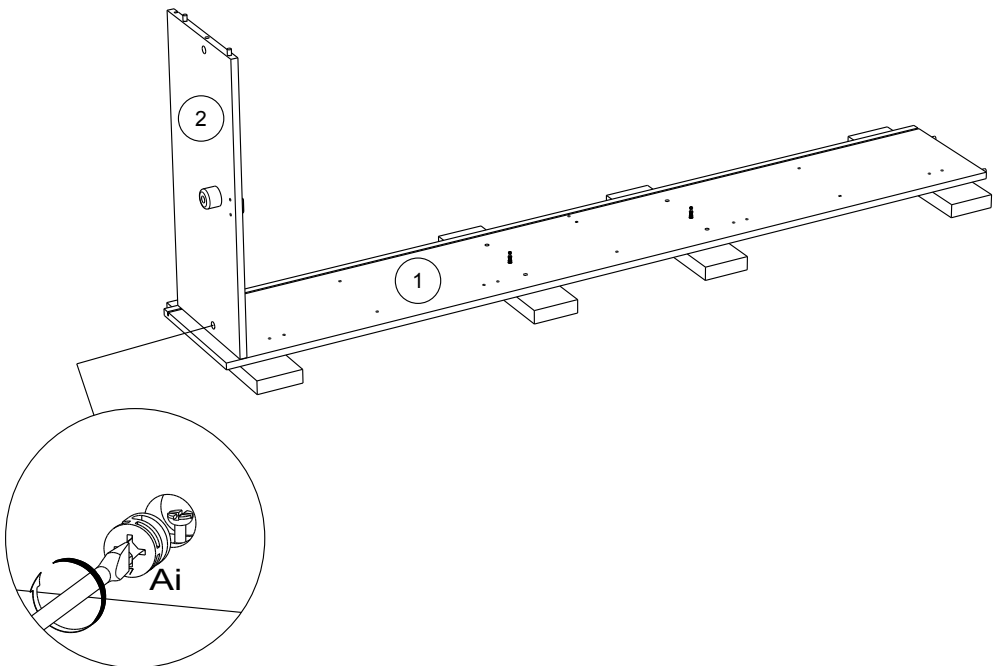
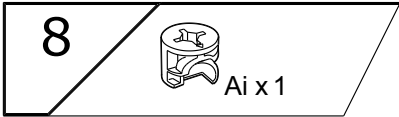
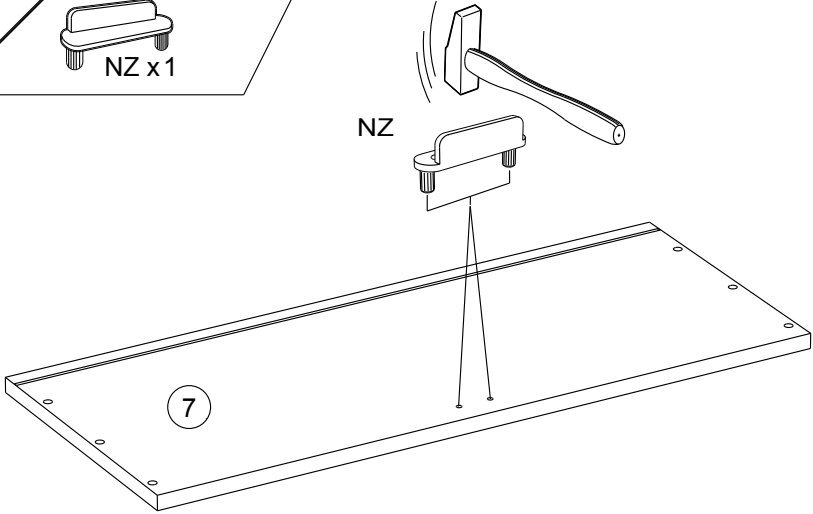
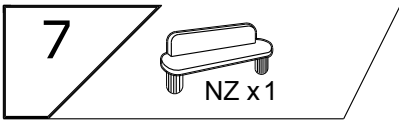

9



Ai x2

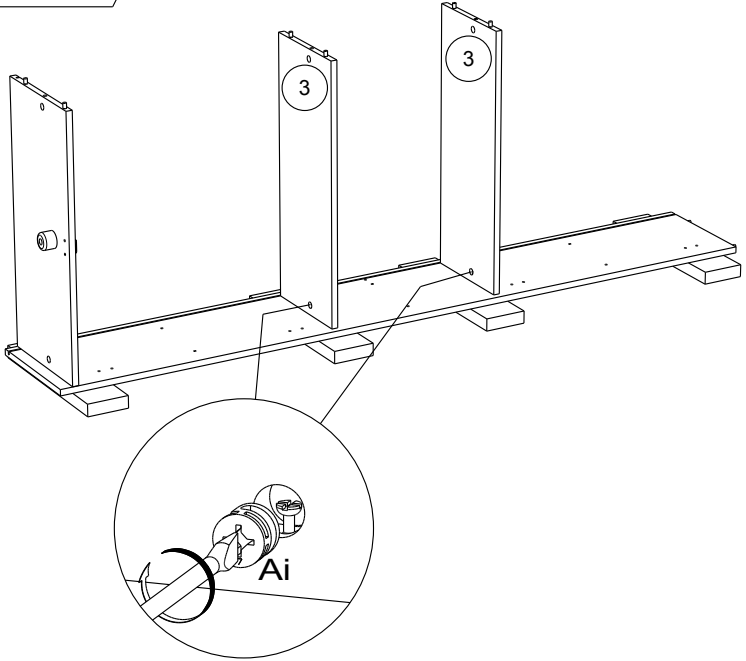

10

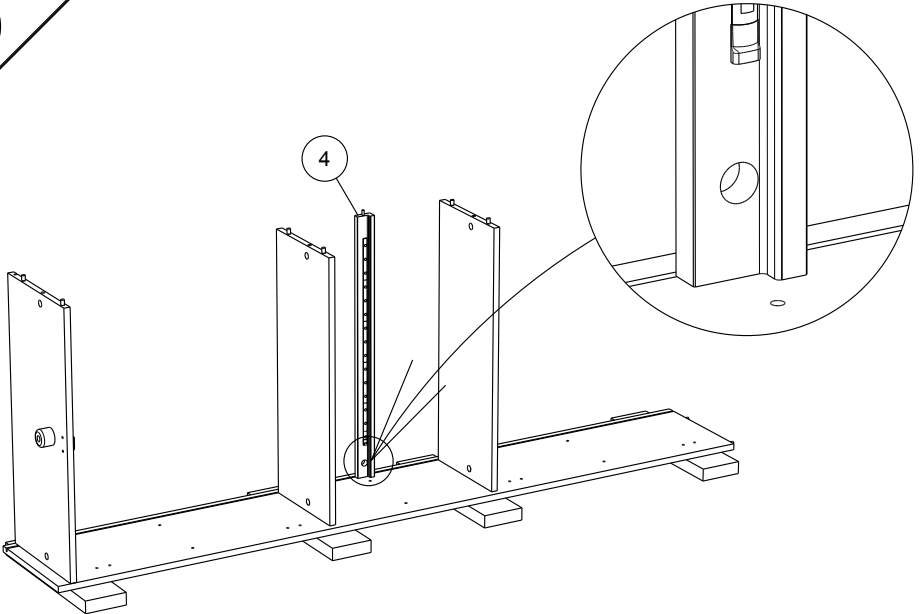



11

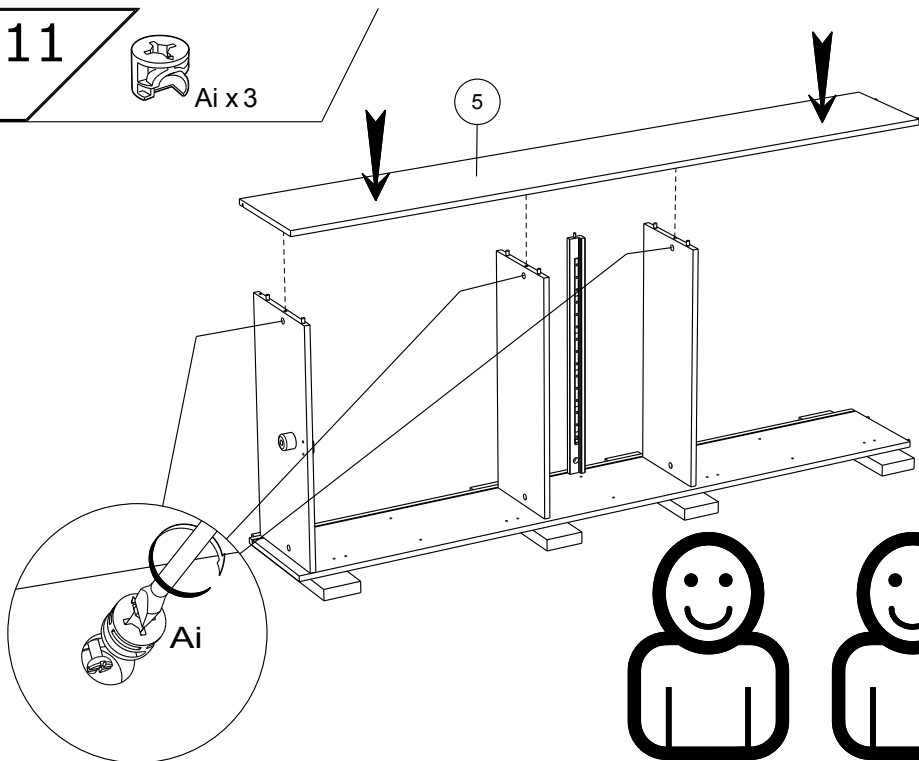

12

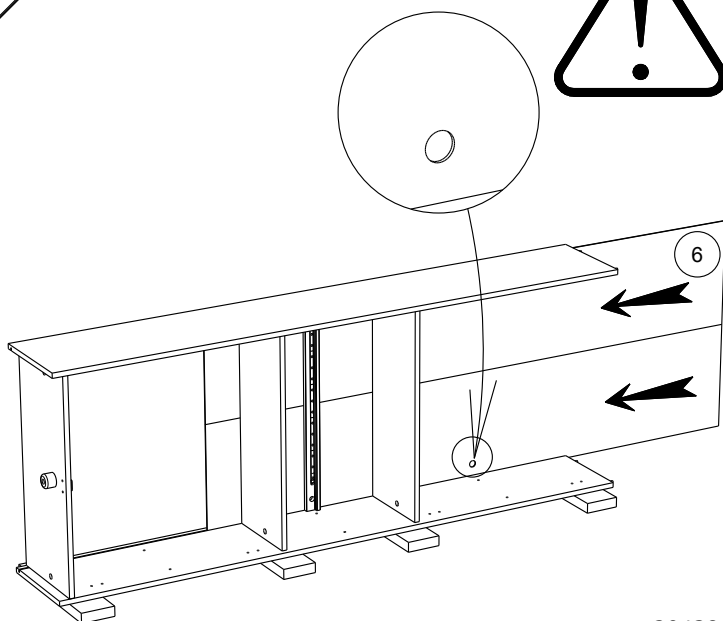

13

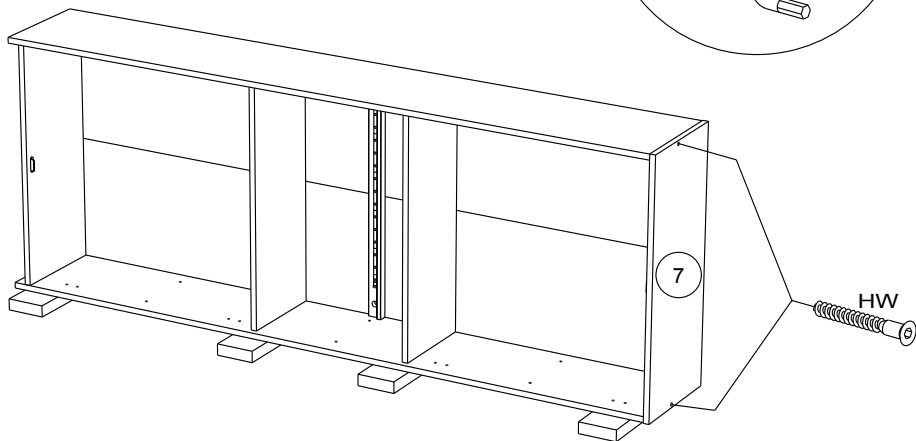
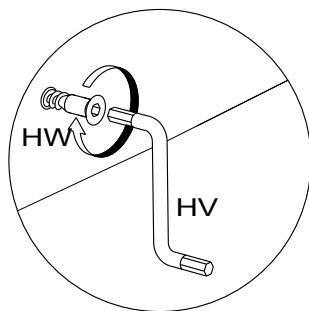
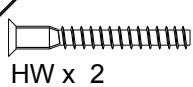

14

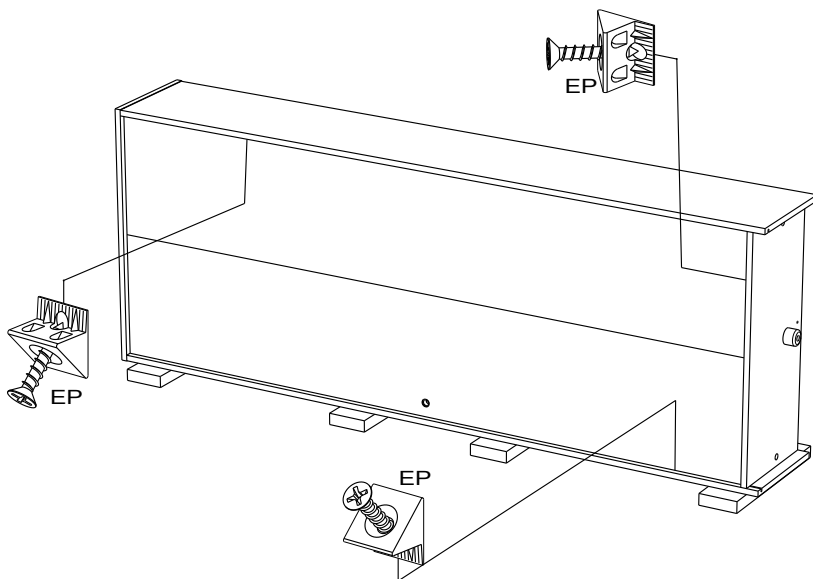

15

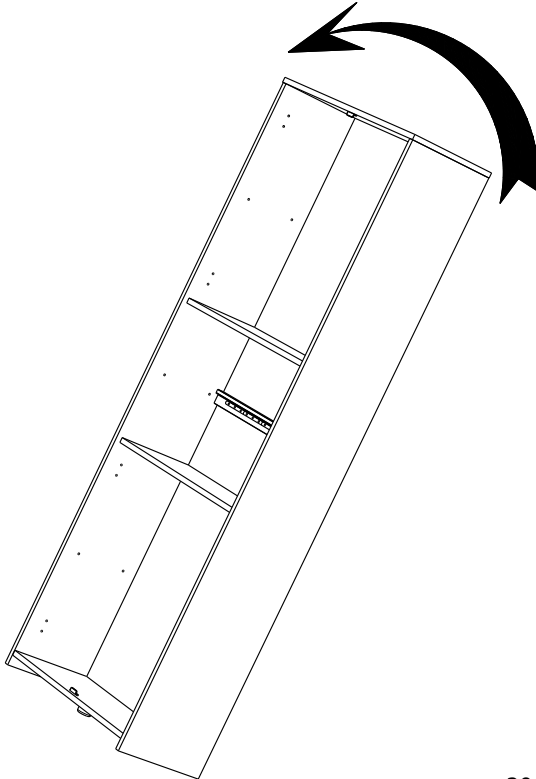
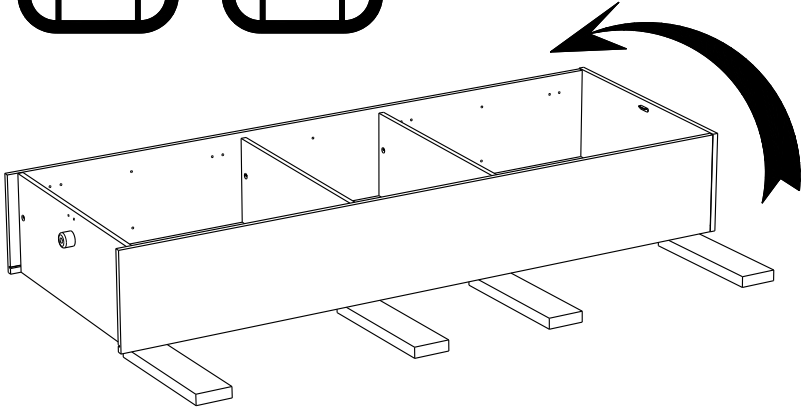
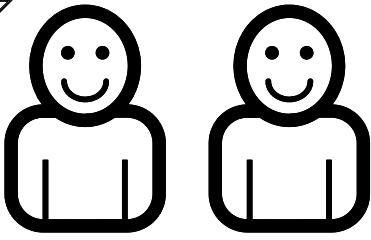

16

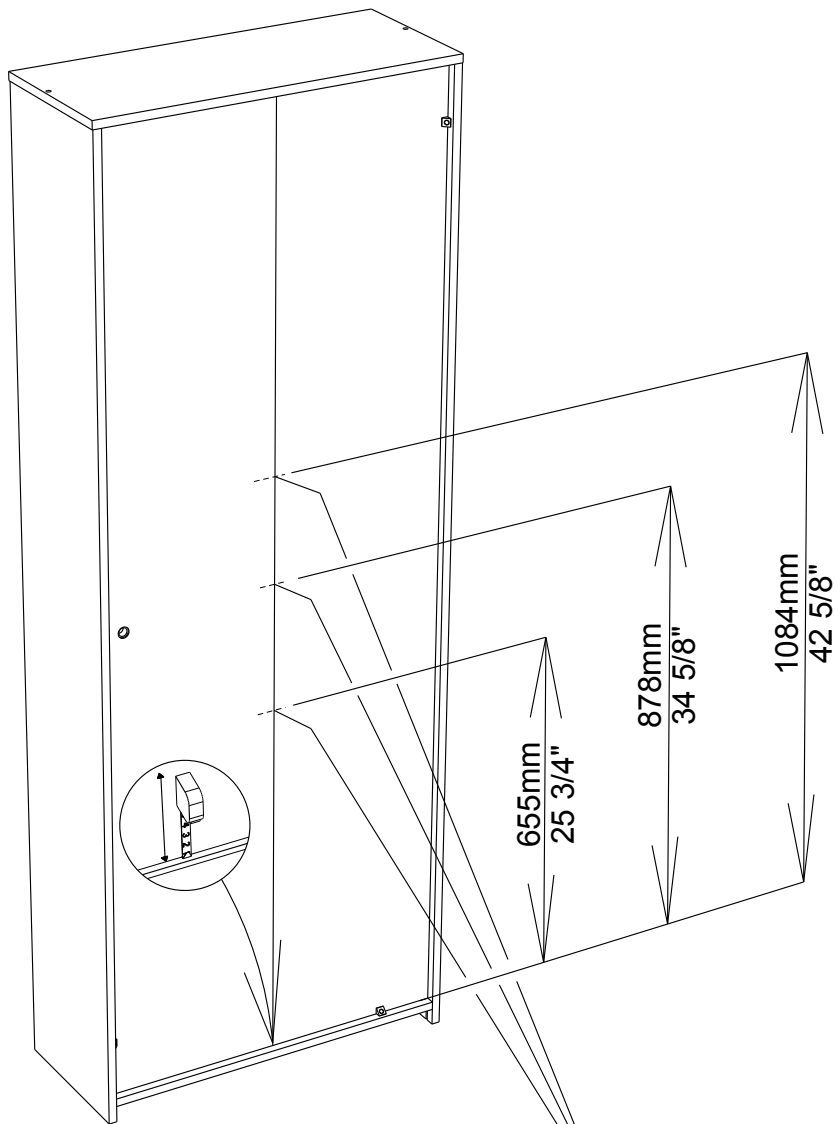
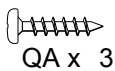

QA

17

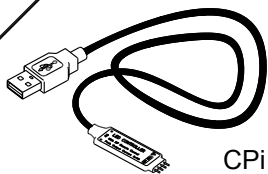

CPI x 1

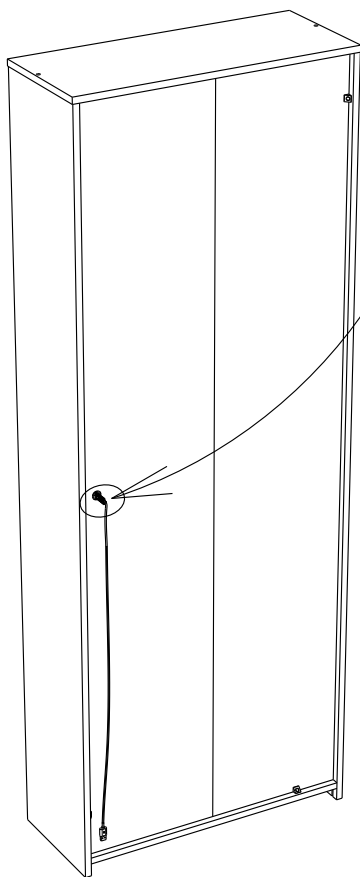
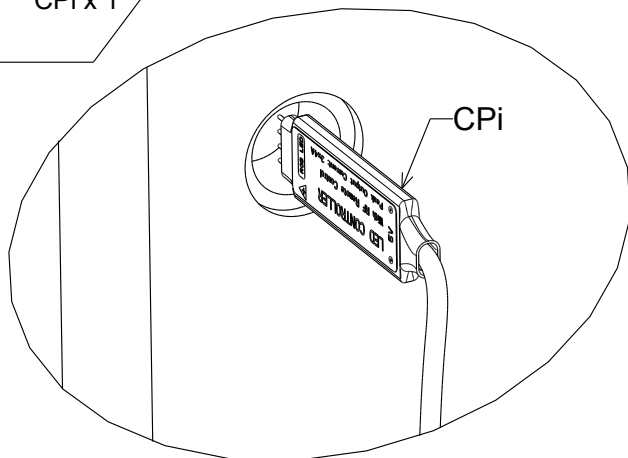

18

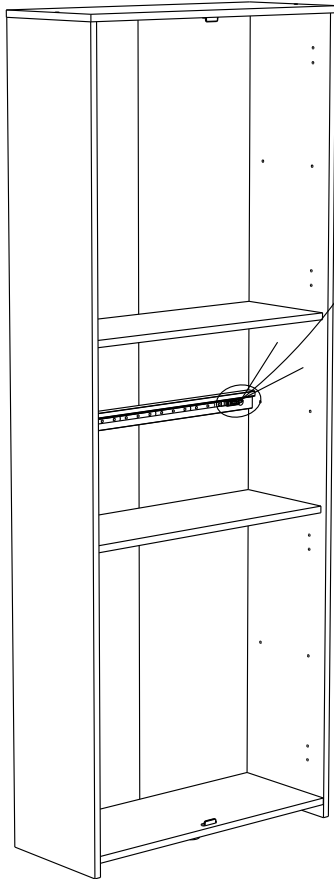
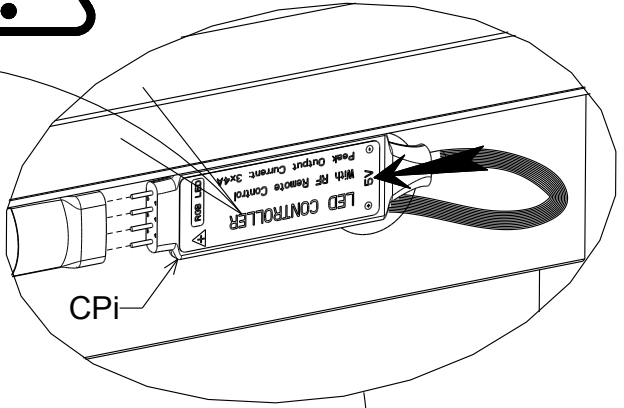
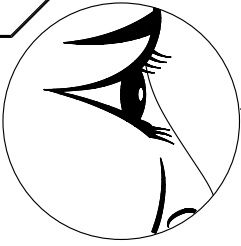

19



BPN x 1



XY x 2

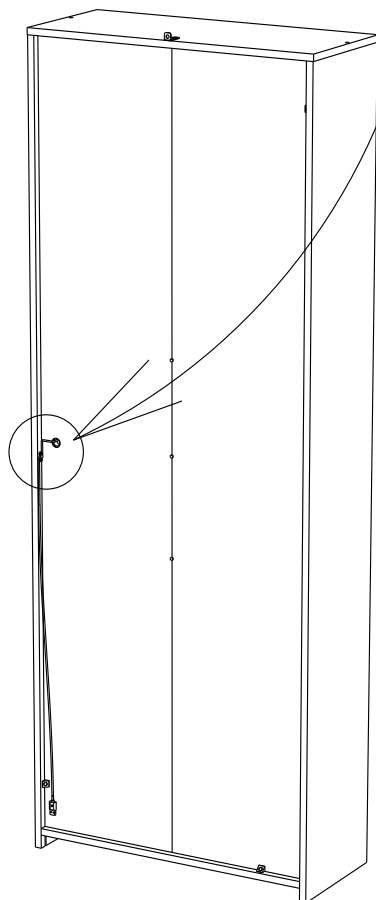
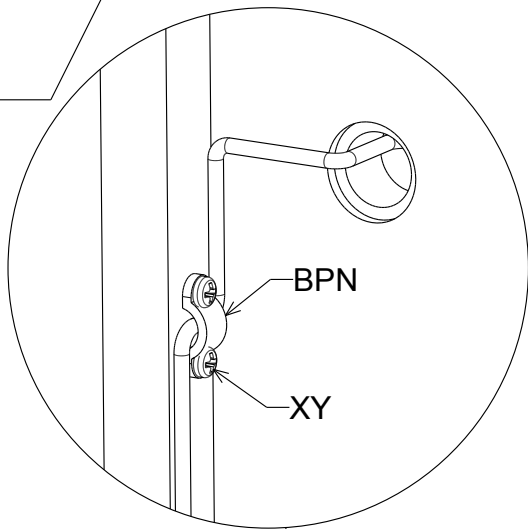

**FR OBLIGATOIRE:** Pour votre sécurité, fixation du meuble au mur.

Attention, la fixation doit être réalisée par une personne compétente car cela nécessite des chevilles adaptées à la nature de votre mur.

**EN OBLIGATORY:** For your safety, due to risk of overturning, this product must be used with the wall attachment device provided, this should be carried out by a competent person.

**DE OBLIGATORISCH:** Zu Ihrer Sicherheit, befestigen Sie das Möbel an der Wand.

Achtung: Diese Befestigung ist durch eine fachlich kompetente Person vorzunehmen.

Hierfür sind für die Bauweise Ihrer Wand geeignete Dübel einzusetzen.

**ES OBLIGATORIO:** Por su seguridad, fijar el mueble a la pared.

Advertencia: la fijación la ha de llevar a cabo por personal adecuado, ya que requiere el uso de tacos que se adapten al tipo de pared.

**PT OBRIGATÓRIO:** Para sua segurança, fixação do móvel ao muro.

Atenção: a fixação deverá ser efetuada por pessoa habilitada, visto que são necessárias cavilhas adaptadas ao tipo de parede.

**IT OBBLIGATORIO:** Avvertenza di sicurezza, il fissaggio del mobile a parete deve essere realizzato da una persona competente, in quanto l'operazione richiede l'impiego di tasselli adatti alla natura del muro.

**NL VERPLICHT:** Voor uw veiligheid, bevestiging van het meubel aan de muur.

Opgelet de bevestiging moet worden uitgevoerd door een bekwaam persoon daar dit voor uw type muur geschikte pluggen vereist.

**CZ POVINNÝ:** Z bezpečnostních důvodů, upevněte nábytek do zdi.

Pozor, upevnění je třeba svěřit kompetentní osobě, neboť vyžaduje hmoždinky vhodné pro vaši zed'.

**HU KÖTELEZŐ:** Az Ön biztonsága érdekében, a bútor falra rögzítése.

Figyelmeztetés: a rögzítés csak megfelelő szakképesítéssel rendelkező személy által végezhető el, mert a rögzítéshez a falnak megfelelő csavarokra van szükség.

**PL OBOWIĄZKOWY:** Dla bezpieczeństwa, mocowanie mebla do ściany.

Uwaga, mocowanie musi zostać wykonane przez osobę kompetentną, ponieważ wymaga to zastosowania kołków dostosowanych do rodzaju ściany.

**RO OBLIGATORIU:** Pentru securitatea dumneavoastră, fixarea mobilierului de perete.

Atenție, fixarea trebuie să fie realizată de o persoană calificată, deoarece sunt necesare dispozitive de fixare adaptate caracteristicilor peretelui dumneavoastră

**RU ОБЯЗАТЕЛЬНЫЙ:** Для вашей безопасности Крепление мебели к стене

Внимание! Крепление должно производиться опытным специалистом, т.к. для такой установки потребуются штифты, соответствующие типу вашей стены.

**SK POVINNÉ:** Z bezpečnostných dôvodov, nábytok upevnite k stene.

Dbajte na to, aby upevnenie vykonala kompetentná osoba, pretože pri upevňovaní sa vyžadujú kolíky vhodné do materiálu, z ktorého je stena vyrobená.

**SL OBVEZNO:** Za vašo varnost, Enota naj bo pritrjena na steno. Pozor: To naj stori kompetentna oseba, ker je potrebno uporabiti pravilni nosilec glede na vrsto stene ki jo uporabljate.

**TR ZORUNLU:** Güvenliğiniz için, Mobilyanın duvara sabitlenmesi

Dikkat, sabitleme işlemi uzman biri tarafından yapılmalıdır çünkü bu işlem için duvarınızın malzemesine uygun dübellerin kullanılması gerekmektedir

**EL ΥΠΟΧΡΕΩΤΙΚΟΣ:** Για την ασφάλειά σας στερέωση των επίπλων στον τοίχο.

Προσοχή, η στερέωση πρέπει να γίνεται από ικανό άτομο, καθώς απαιτούνται σφηνές προσαρμοσμένες στη φύση του τοίχου σας.

**AR واجب:** لسلامتك الشخصية, تثبيت قطعة الأثاث على الحائط

تحذير، يجب أن يقوم شخص متخصص بعملية التثبيت على الحائط إذ أنها تتطلب اسفينا معيناً يتوافق مع طبيعة الحائط نفسه.

**ZH 義務性:** 为了您的安全，本产品必须靠墙安装。

NB 本产品必须由专业人士安装，且您必须使用符合您的墙壁类型的罗威纤维管。



20



BLL x1



VG x1

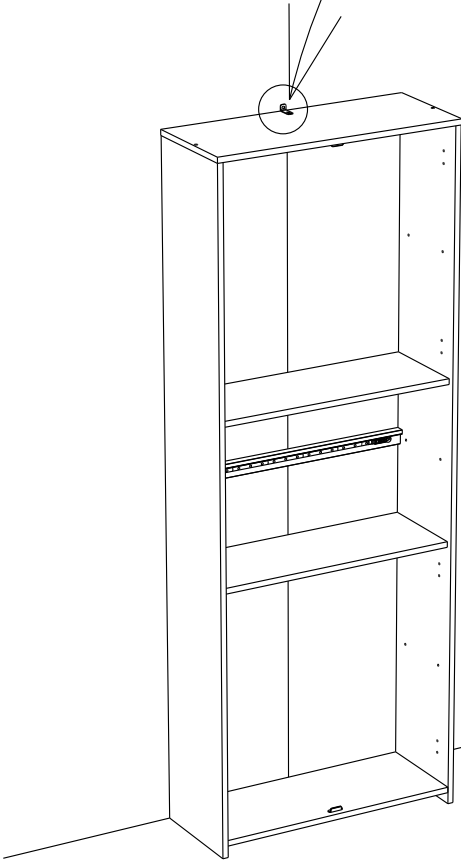
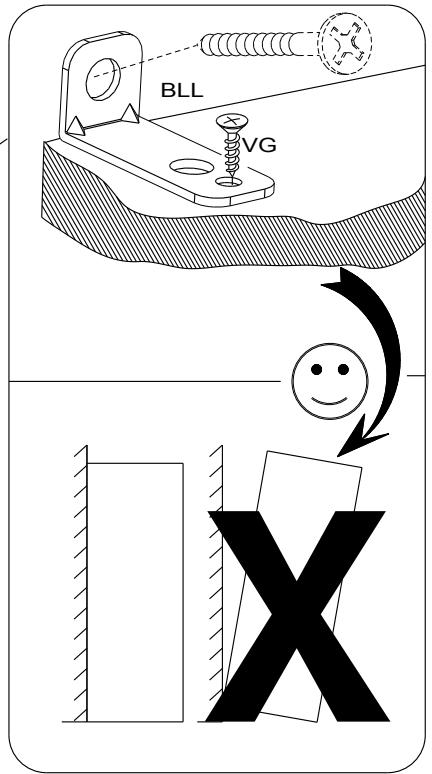

21

BWD x 8

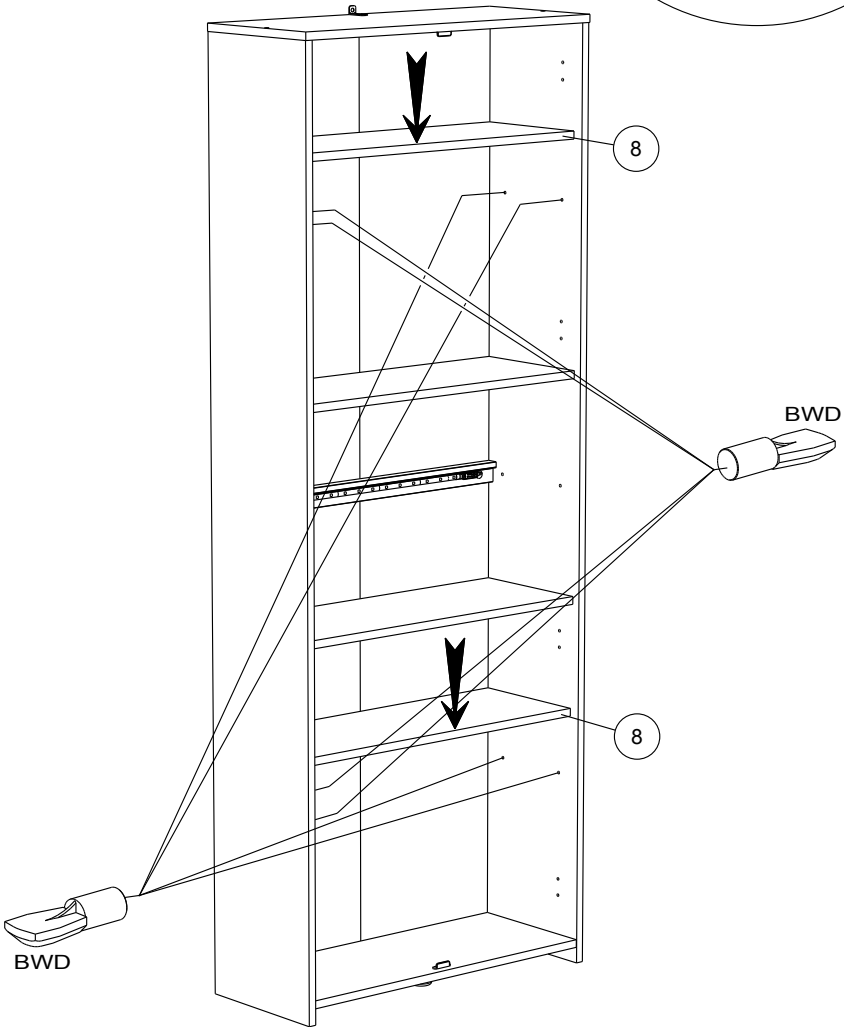
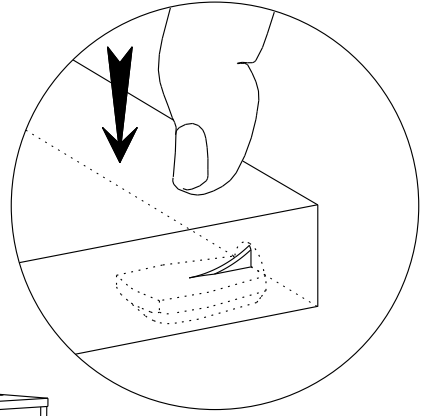

22



DJ x 2



AOP x 2



NT x2

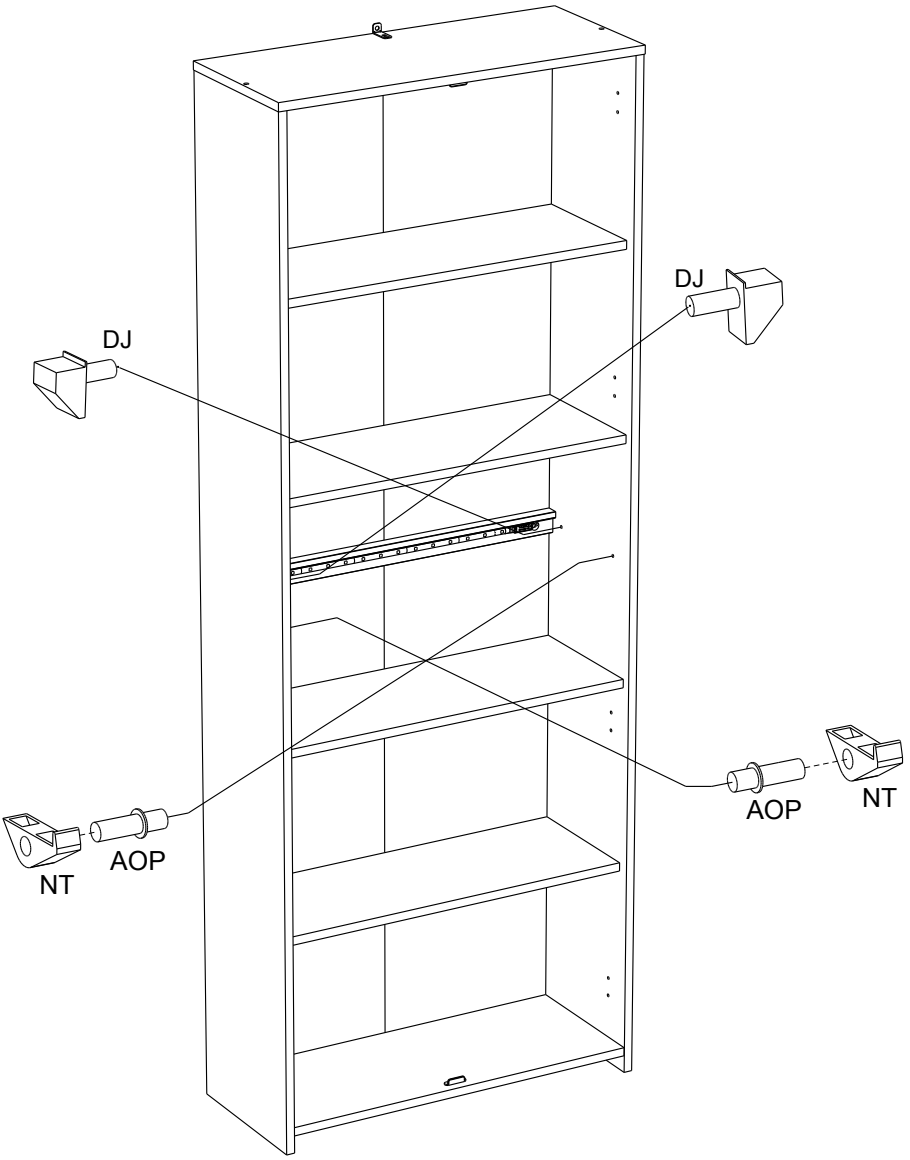

23

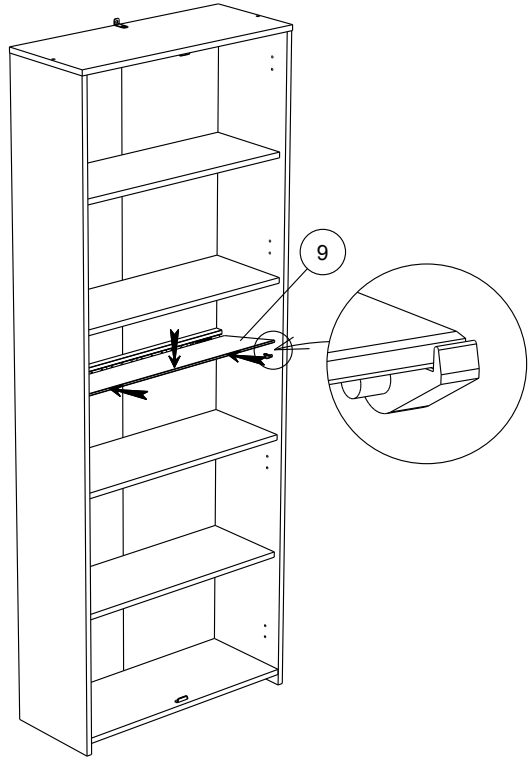

24

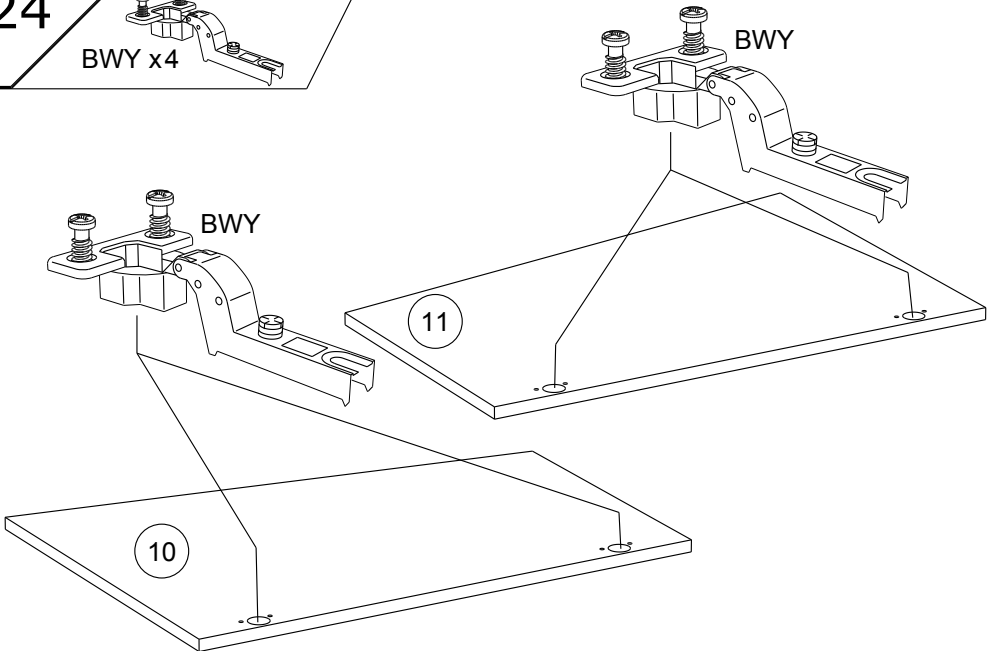
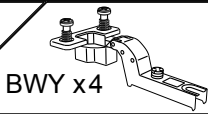

25A

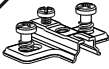

BWU x4



OO x 8

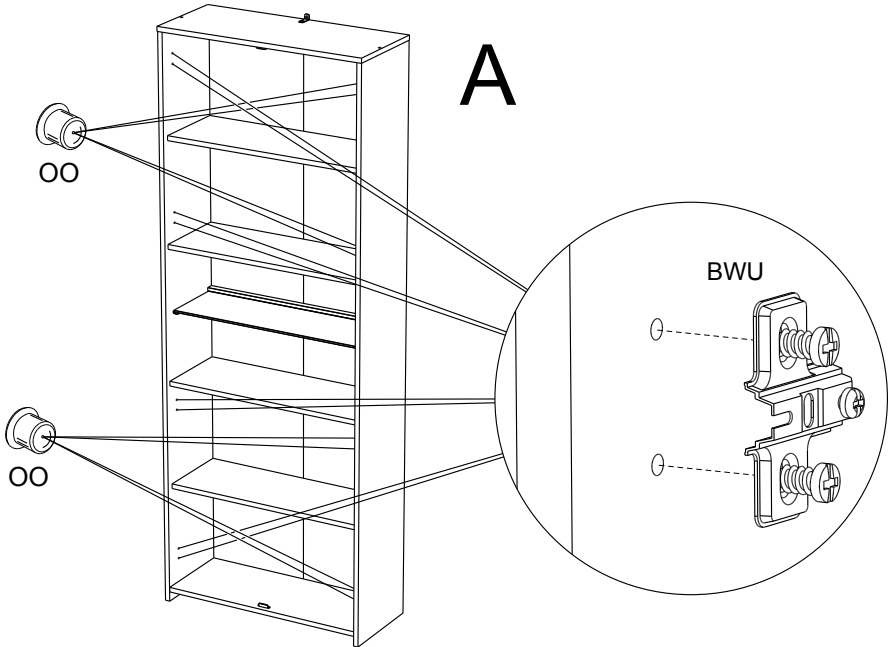

25B

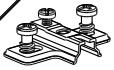

BWU x4



OO x 8

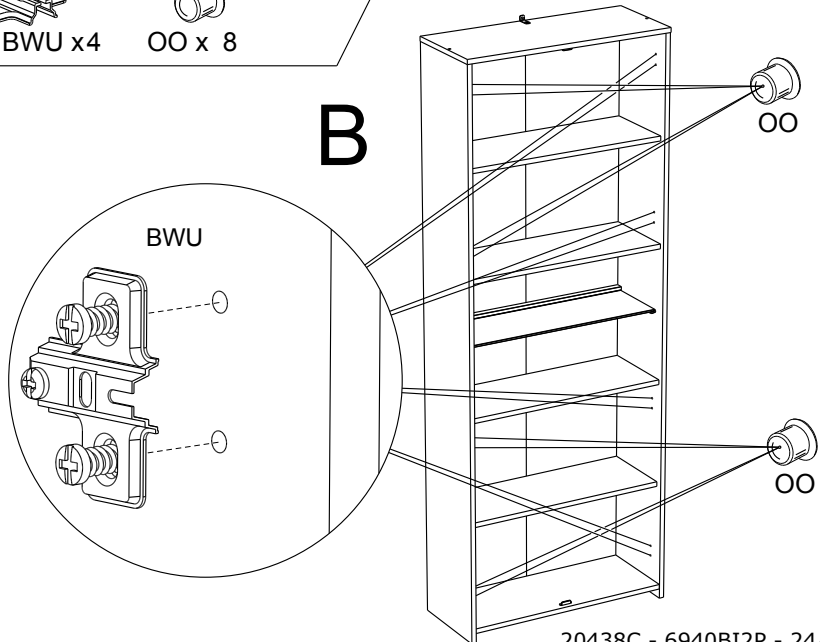

26A

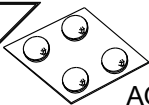

AQO x 1

AQO

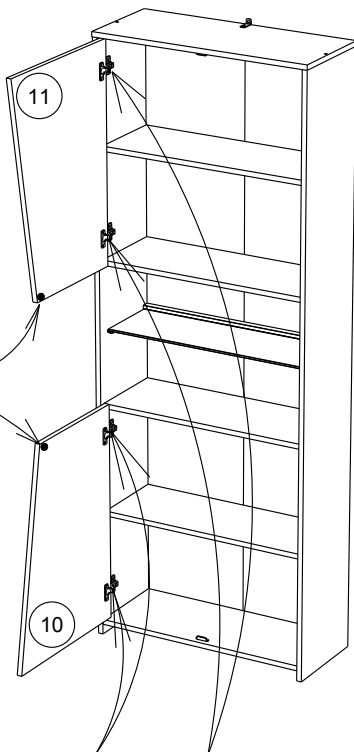

RCH-N

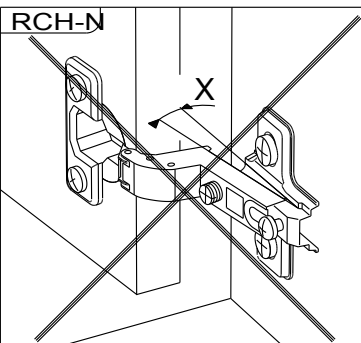

### MONTAGE

- (GB) LEAFLET
- (D) AUFBAUANLEITUNG
- (E) MONTAJE
- (P) MONTAGEM
- (I) MONTAGGIO
- (NL) MONTAGE

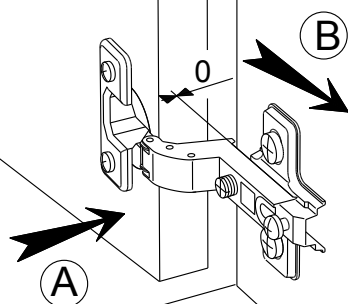

REGLAGE (GB) ADJUSTING (E) AJUSTER (I) AGGIUSTAMENTO  
 (D) ANPASSUNG (P) REGULACAO (NL) AFSTELLING

(A)

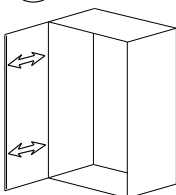

(B)

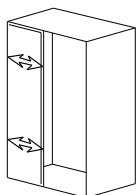

(C)

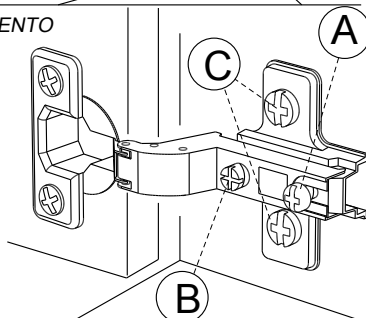
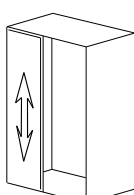

26B

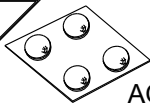

AQO x 1

B

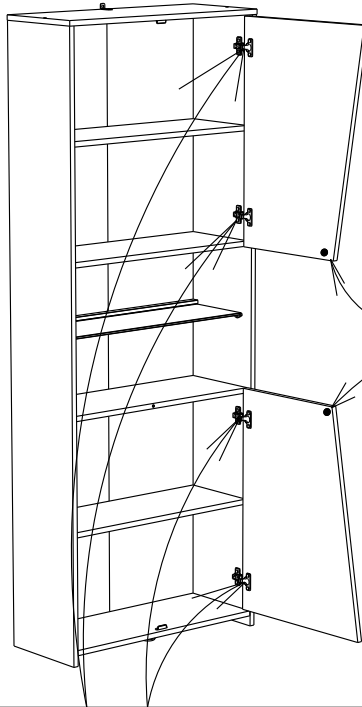

AQO



RCH-N

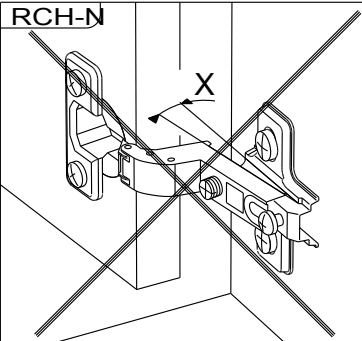

MONTAGE

- (GB) LEAFLET
- (D) AUFBAUANLEITUNG
- (E) MONTAJE
- (P) MONTAGEM
- (I) MONTAGGIO
- (NL) MONTAGE

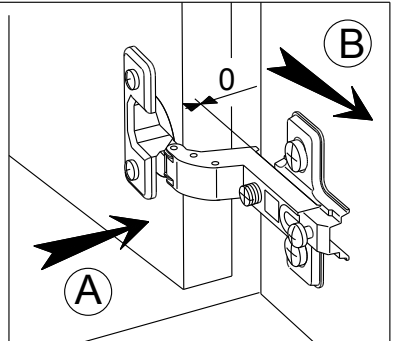

REGLAGE (GB) ADJUSTING (E) AJUSTER (I) AGGIUSTAMENTO  
 (D) ANPASSUNG (P) REGULACAO (NL) AFSTELLING

A

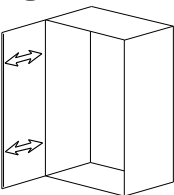

B

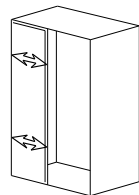

C

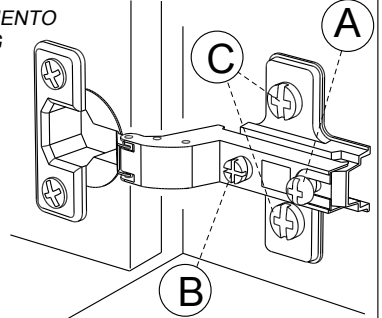
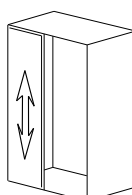

x1

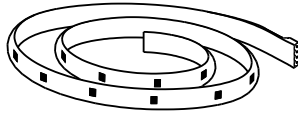

CPH x1

STRIP LED FLEX RGB USB

Max. 10 Watts 1,85 A  
USB 5V DC



IP20



Max. 10W – 1,85A

i

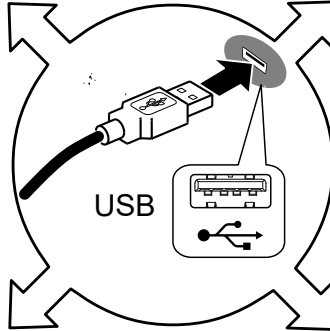
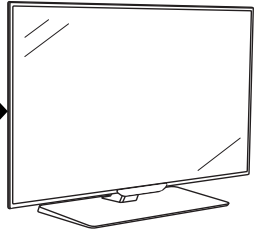
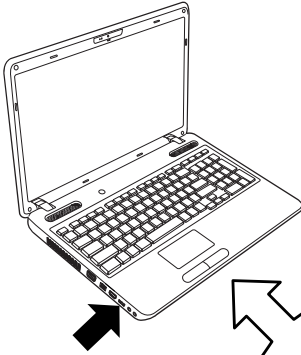

USB

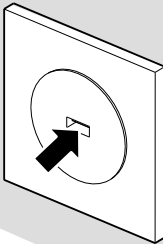

FR Non inclus  
EN Not included  
DE Nicht im Lieferumfang enthalten  
ES No incluido  
PT Não incluído  
IT Non incluso  
NL Niet inbegrepen  
RU Не включительно  
PL Nie wliczone  
SK Nie sú zahrnuté  
CS Není součástí dodávky  
HU Nem tartalmazza  
RO Nu sunt incluse  
TR Dahil değil  
EL δεν περιλαμβάνονται  
SL Ni vključeno  
ZH 不包含  
AR غير المدرج