

80-20101-40

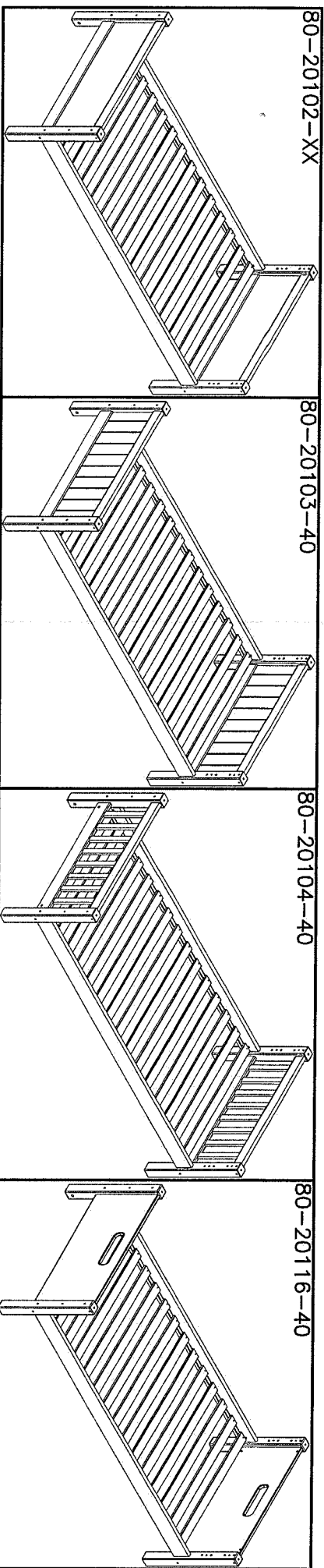

See assembly instruction in box no.
 Voir notice de montage dans la caisse no.
 Siehe Aufbauanleitung im Karton no.
 Zie voor de montage-instructie pakketnr.

Before assembling this product, please ensure that all the components supplied comply with the list on this page. All Screw-type fittings can be tightened with this tool.

Avant de commencer l'assemblage, veuillez vous assurer que tous les objets fournis sont conformes à la liste présente. Tous les vis pour vis à serrés par cet outil.

Bevor Sie mit dem Aufbau beginnen, kontrollieren Sie ob alle auf der Zeichnung angegebenen Teile vorhanden sind. Bitte verwenden Sie zur Montage einen Kreuzschraubzieher und den beiliegenden Innerschraubenschlüssel.

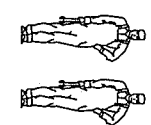

Waren-nr. Part no. Ref No	Stück. Qty. Qte.
Siehe Bild-nr. See picture no. Image no	Mass Dim. Dim.

12-06306473-40 2 stick/pcs.

12-06306474-40 2 stick/pcs.

1305-19672-40 2 stick/pcs.

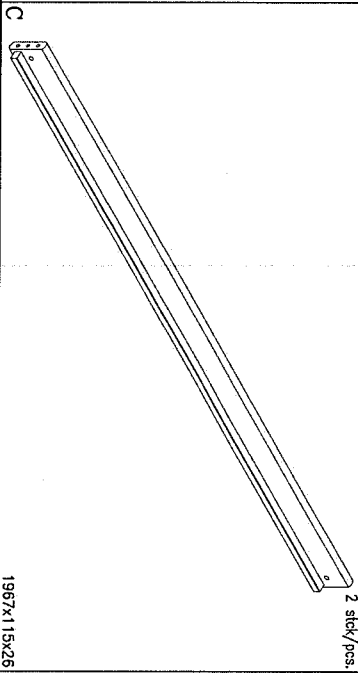
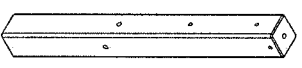
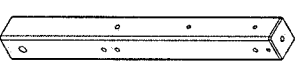

A 647x63x63 3922-08018 8 stick/pcs.

B 647x63x63 3930-10050 16 stick/pcs.

C 647x63x63 3909-70100 4 stick/pcs.

1967x115x25 30 stick/pcs.

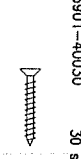
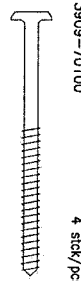
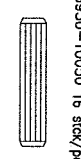

Z1 M8/ø12x18 mm 3913-08110 8 stick/pcs.

Z2 ø10x50 mm 3938-000081-2 16 stick/pcs.

Z3 3938-00010-2 20 stick/pcs.

Z4 ø7x100 mm 3938-00016-2 4 stick/pcs.

4033-005 1 stick/pcs.

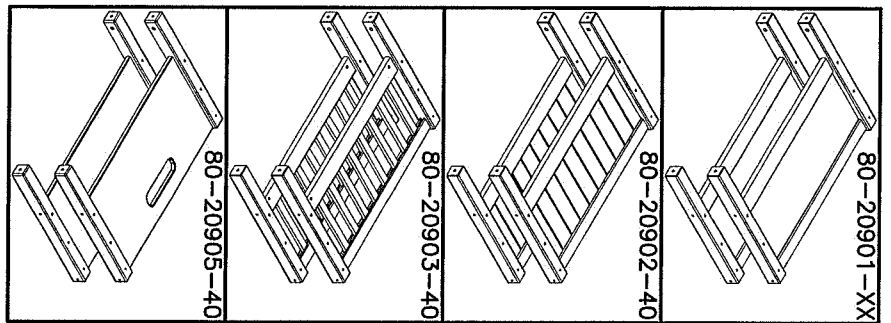
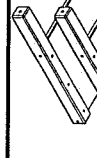
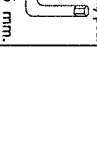
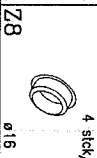
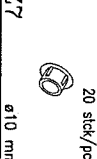
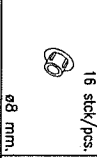
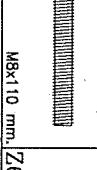
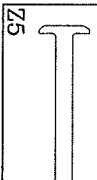

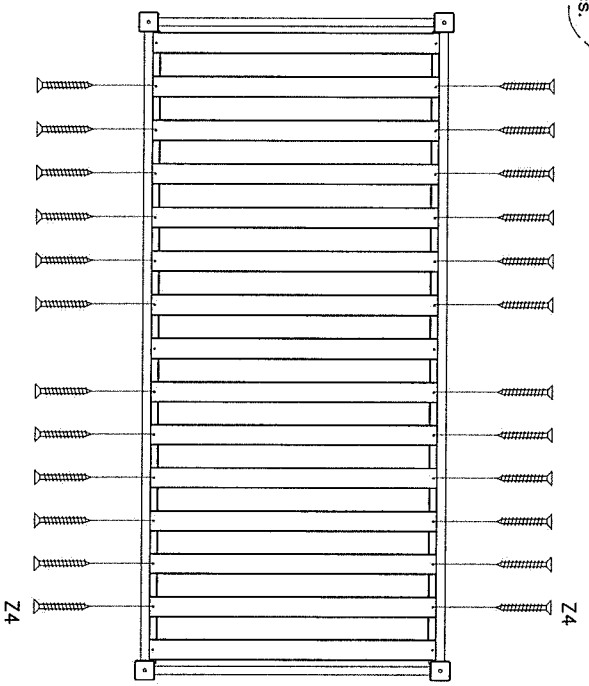
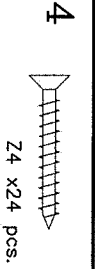
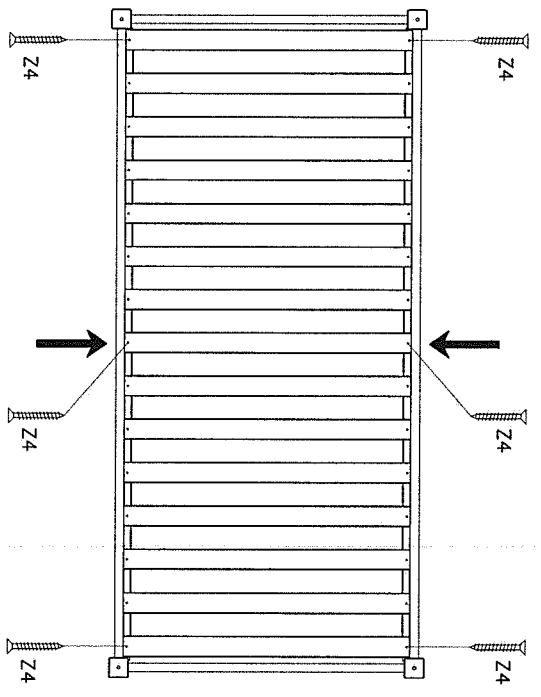
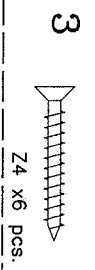
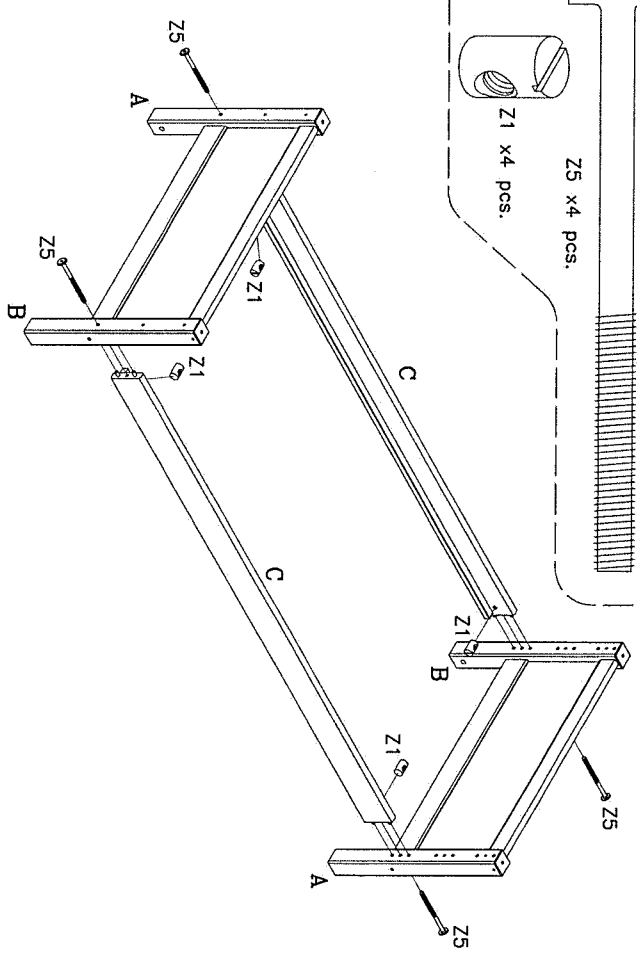
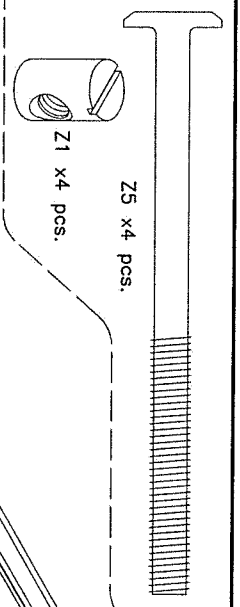
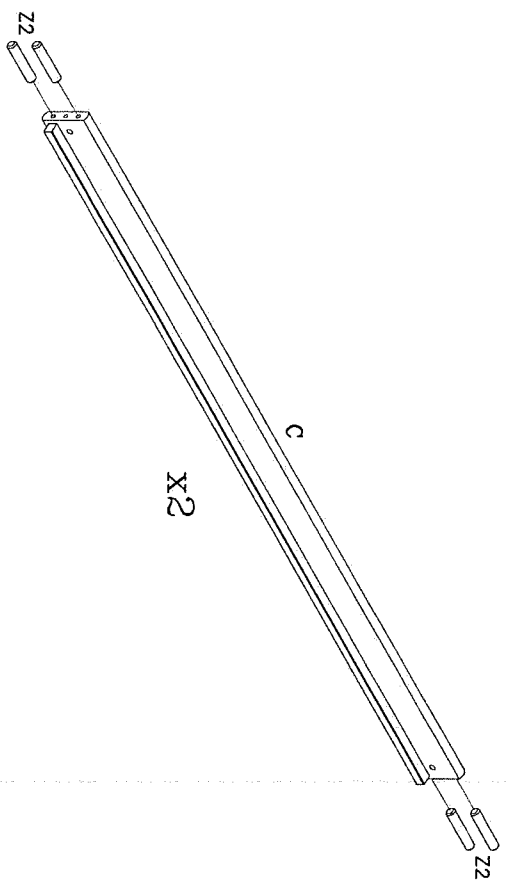
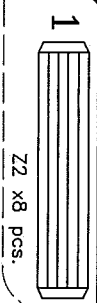

80-20905-40 White

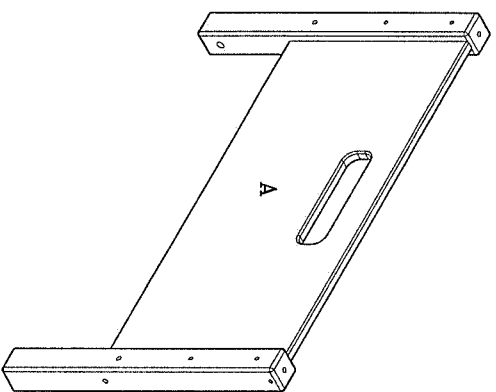

Before assembling this product, please ensure all the components supplied with the list on this page. All screw-type fittings can be tightened with this tool.

Avant de commencer l'assemblage, veuillez vous assurer que tous les objets indiqués sont présents dans la série par cet outil.

Bevor Sie mit dem Aufbau beginnen, kontrollieren Sie die Liste auf der Zeichnung. Alle Schrauben sind für die Montage eines Kreuzschraubenzieher und dem beiliegenden Innensechskantschlüssel.

4301-2208631-40 2 stick/pcs

	Z28	M6/Ø10x18mm	4 stick/pcs.	4033-004	1 stick/pcs.	4 mm.
	Z29	M6x110 mm.	4 stick/pcs.			
	Z1		4 stick/pcs.			
	Z22		4 stick/pcs.			
	Z5		4 stick/pcs.			

Z1, Z2, Z5 Fittings in single / bunk bed box.
 Z1, Z2, Z5 Beschläge im Einzel- / Etagenbett Karton.
 Z1, Z2, Z5 Raccords en lit simple / lit superposé.
 Z1, Z2, Z5 Fittings in het enkelspel / stapelbed boxen.

<p>1</p> <p>Z2 x8 pcs.</p> <p>Z29 x2 pcs. Z5 x2 pcs. Z1 x2 pcs. Z28 x2 pcs.</p>	<p>Z29 x2 pcs. Z5 x2 pcs. Z1 x2 pcs. Z28 x2 pcs.</p> <p>Bunk bed only. Nur Etagen Bett. Lits superposés seulement. Alleen stapelbed</p>
<p>Z29 x2 pcs. Z5 x2 pcs. Z1 x2 pcs. Z28 x2 pcs.</p> <p>Z29 x2 pcs. Z5 x2 pcs. Z1 x2 pcs. Z28 x2 pcs.</p>	<p>Z29 x2 pcs. Z5 x2 pcs. Z1 x2 pcs. Z28 x2 pcs.</p> <p>Z29 x2 pcs. Z5 x2 pcs. Z1 x2 pcs. Z28 x2 pcs.</p>

80-20601-40

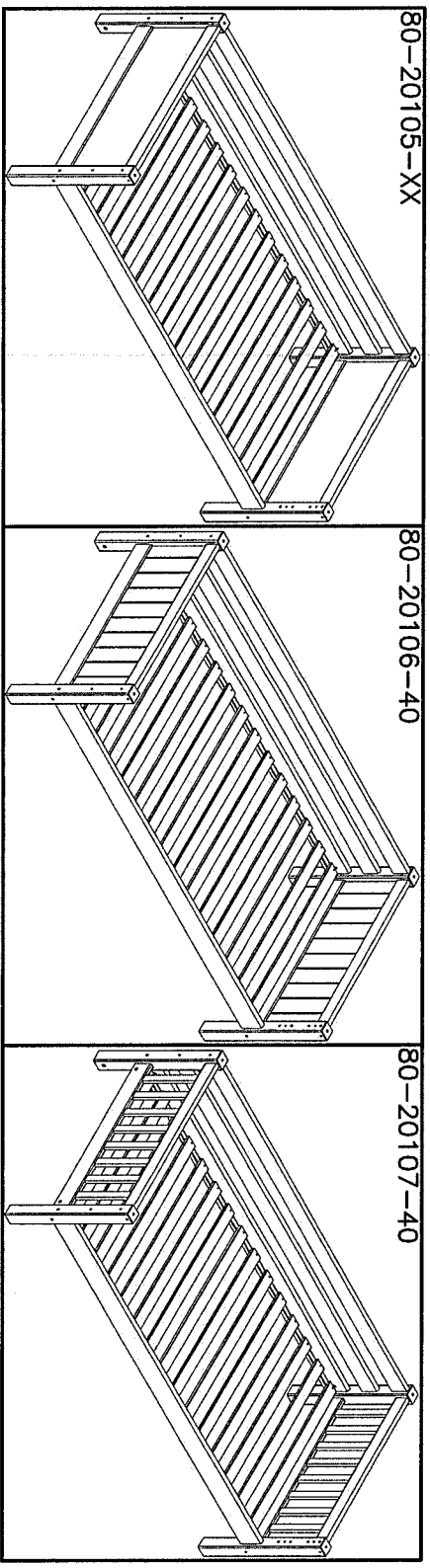

Before assembling this product, please ensure that all the components supplied comply with the list on this page. All Screw-type fittings can be tightened with this tool.

Avant de commencer l'assemblage, veuillez contrôler si tous les objets indiqués sont présents. Tous les vis peuvent être serrés par cet outil.

Bevor Sie mit dem Aufbau beginnen, kontrollieren Sie ob alle auf der Zeichnung angegebenen Teile vorhanden sind. Bitte verwenden Sie zur Montage einen Kreuzschraub-zieh- und den beiliegenden Innensechskantschlüssel.



Ware-nr.
Part no.
Réf No

Stück
Qty.
Qté.

Mass
Dim.
Dim.

Siehe Bild-nr.
See picture no.
Image no

12-02619676-40

2 Stück/pcs.

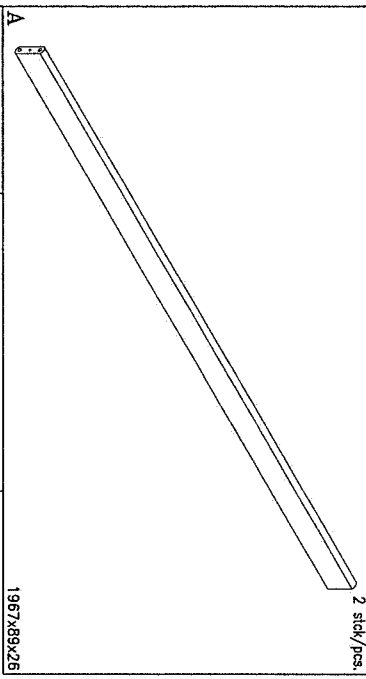

3930-10050 8 Stück/pcs. 13909-70100

4 Stück/pcs.

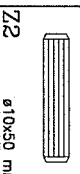

Z3

ø7x100 mm.

See assembly instruction in box no. 80-20101-40

Voir notice de montage dans la caisse no. 80-20101-40

Siehe Aufbauanleitung im karton no. 80-20101-40

Zie voor de montage-instructie pakketnr. 80-20101-40

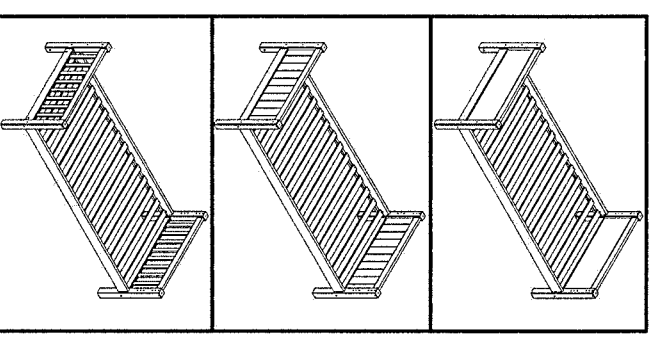

1

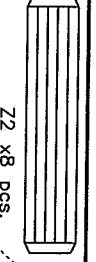

Z2 x8 pcs.

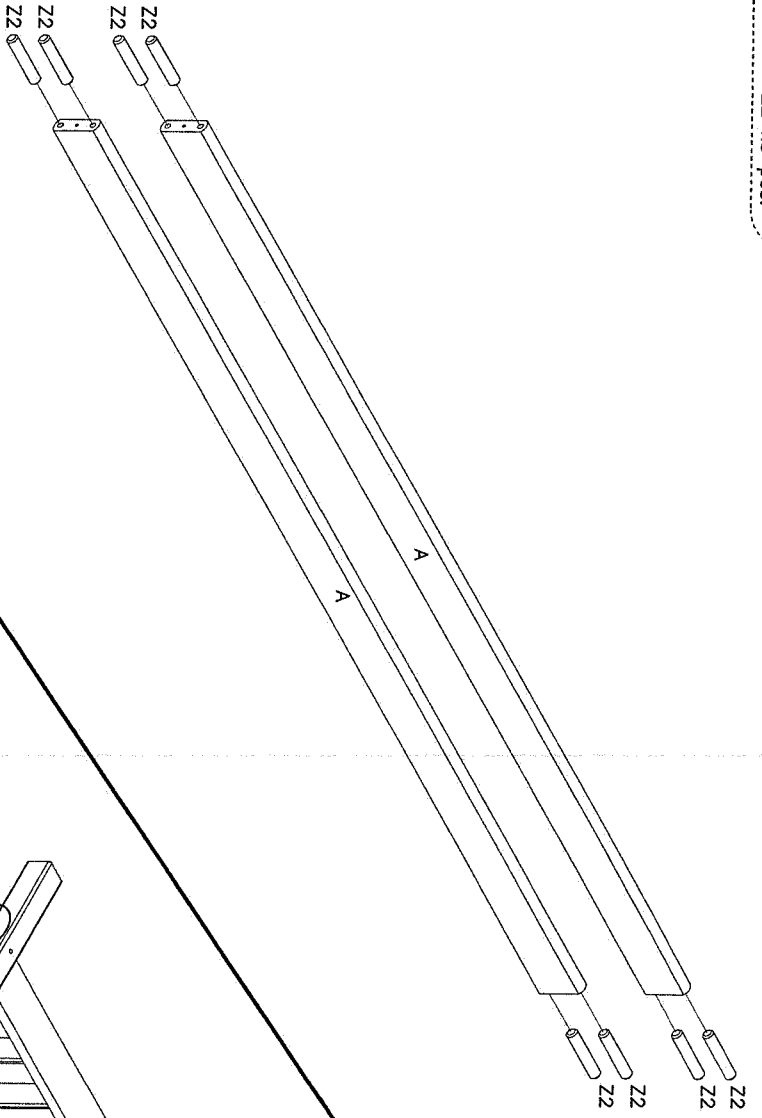

2



Z3 x4 pcs.

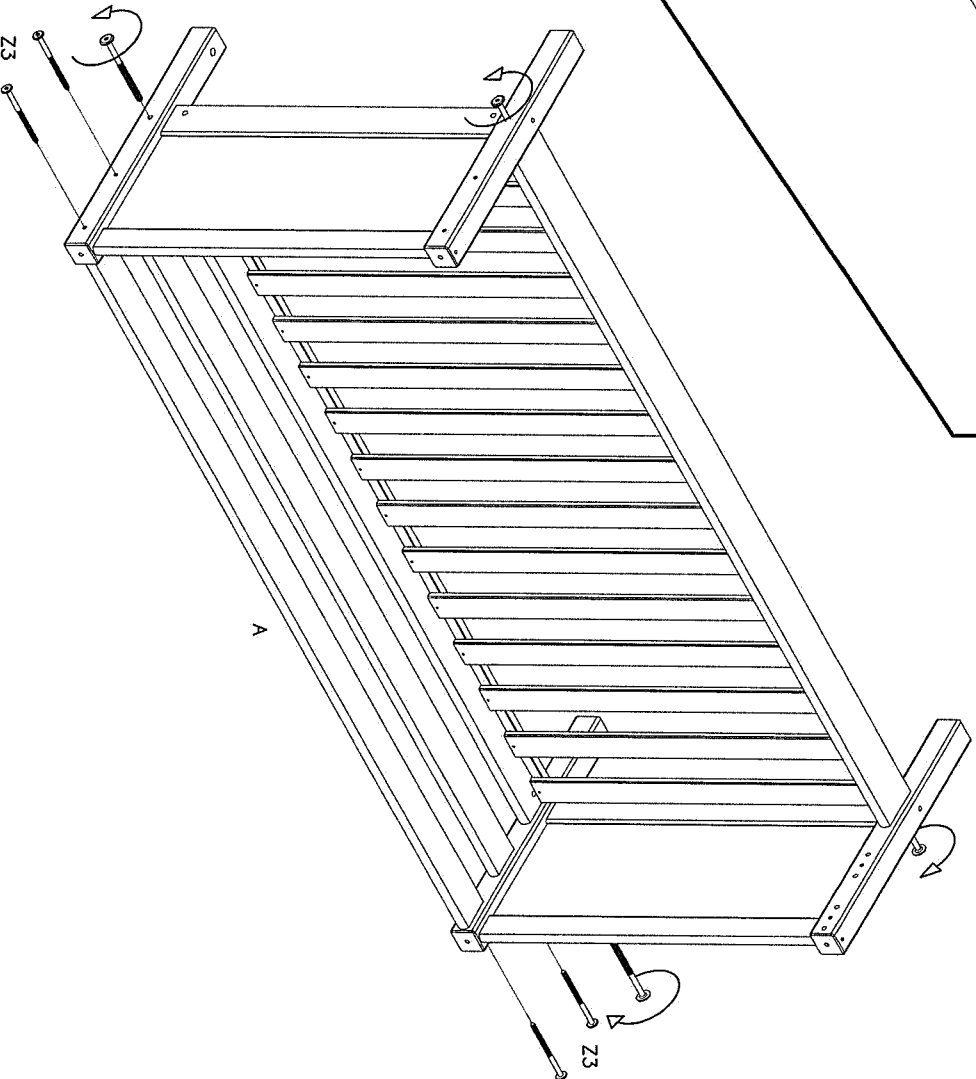

82-20045-40

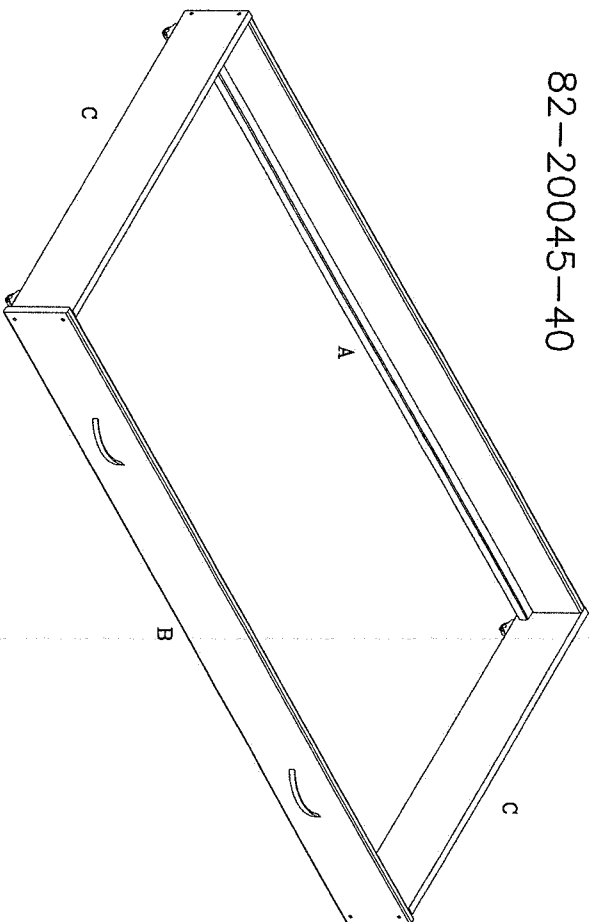

Part No.	Qty.	Dim.	Ware-nr. / Port no. / Ref. No.	Stück / Qty. / Qlté.
1331-19001-40	1	4mm	4mm	1
1900K170X18	1	1900K170X18	1900K170X18	1
1331-19802-40	1	1331-19802-40	1331-19802-40	1
12-01809201-40	2	12-01809201-40	12-01809201-40	2
82-30002	1	82-30002	82-30002	1
3906-70050	8	3906-70050	3906-70050	8
3912-04022	4	3912-04022	3912-04022	4
4033-004	1	4033-004	4033-004	1
Z1	4	3928-000031	3928-000031	4
Z2	4	3940-00012	3940-00012	4
Z3	2	4001-010	4001-010	2
Z4	2	4003-042	4003-042	2
Z5	4	M5/Ø10x1 mm	M5/Ø10x1 mm	4
Z6	4	4003-042	4003-042	4
Z7	2	Ø18/Ø4.5x12 mm	Ø18/Ø4.5x12 mm	2
Z8	2	Ø4 mm	Ø4 mm	2
Z9	2	128 mm	128 mm	2
Z10	2	128 mm	128 mm	2

Before assembling this product, please ensure that all the components supplied comply with the list on this page. All Screw-type fittings can be tightened with this tool.

Avant de commencer l'assemblage, veuillez contrôler si tous les objets indiqués sont présents. Tous les vis peuvent être serrés par cet outil.

Bevor Sie mit dem Aufbau beginnen, kontrollieren Sie ob alle auf der Zeichnung angegebenen Teile vorhanden sind. Bitte verwenden Sie zur Montage einen Kreuzschraubenzieher und den beiliegenden Innensechskantschlüssel.

Ware-nr. / Port no. / Ref. No.

Stück / Qty. / Qlté.

Steh- Bild-nr. / See picture no. / Image no.

Mass / Dim.

(GB): MAINTENANCE INSTRUCTIONS:
Screws and bolts should from time to time be retightened.

(DE): WARTUNG:
Schrauben und Bolzen sollten regelmäßig nachgezogen werden.

(D): PFLEGEHINWEIS:
Schrauben und Bolzen sollen regelmäßig nachgezogen werden.

REINIGUNG:
LACKIERTE MOBEL: Lackierte Holzoberflächen können mit einem sauberen und mildes Seifenwasser gereinigt werden.
GEÖLT MOBEL: Holzoberflächen können mit einem sauberen Lappen ausweichen des Holzes zu bewahren ist eine Öl-Nachbehandlung. Das farblose Öl für die Nachbehandlung der Möbel kann in Ihrem Möbelgeschäft gekauft werden.

(F): CONSEILS 'ENTRETIEN':
Votre lit doit être vérifié périodiquement afin de resserrer les vis.

NETTOYAGE:
LAQUE: Les surfaces bois, laquées, peintes et laminés peuvent être essuyées avec un chiffon et un savon doux.
HUILE: Des surfaces huilées peuvent être nettoyées avec l'eau savonneuse, par exemple. Pour préserver l'aspect naturel du bois - 2 fois par an - l'huile naturelle sans colorant peut être achetée dans votre magasin de meubles.

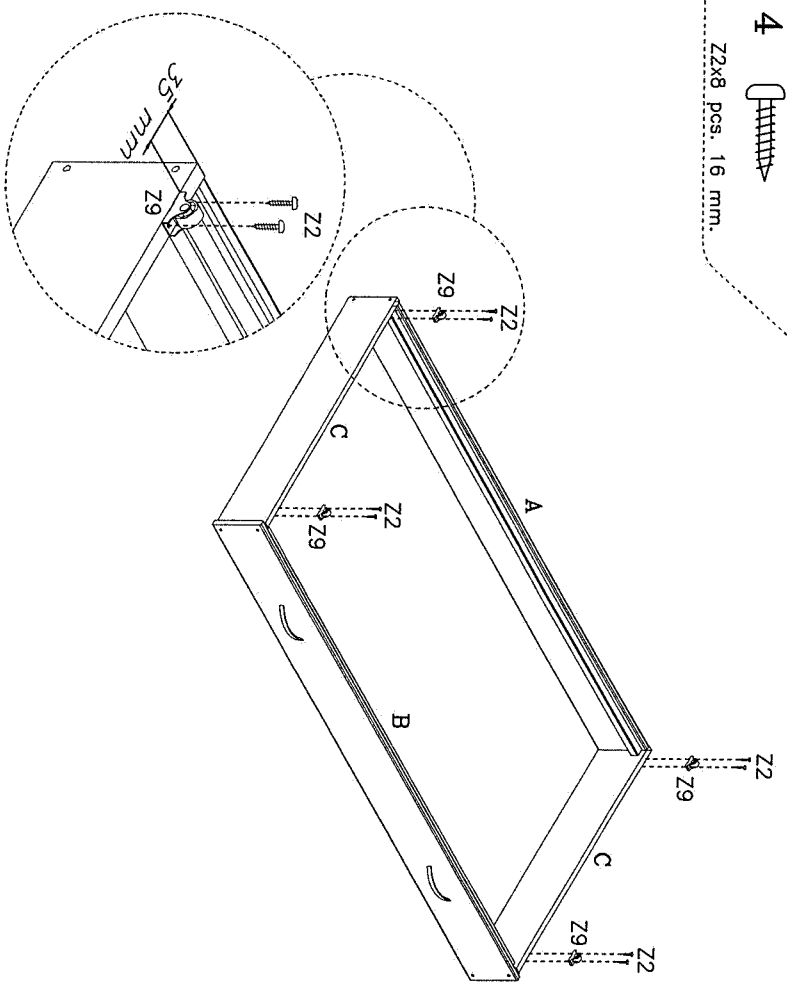
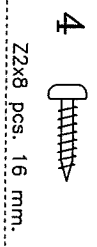
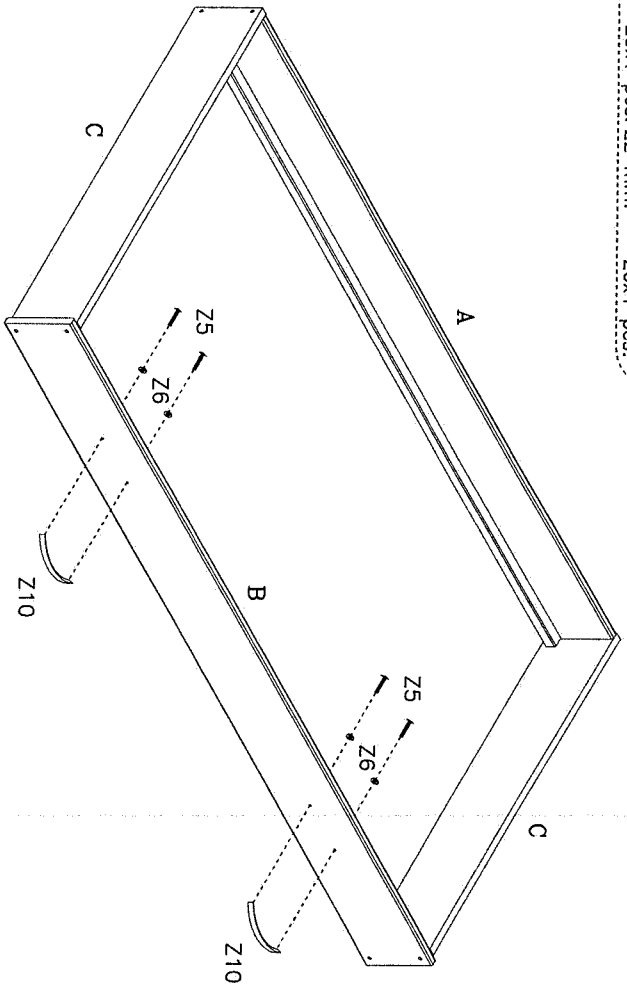
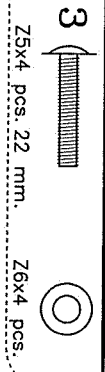
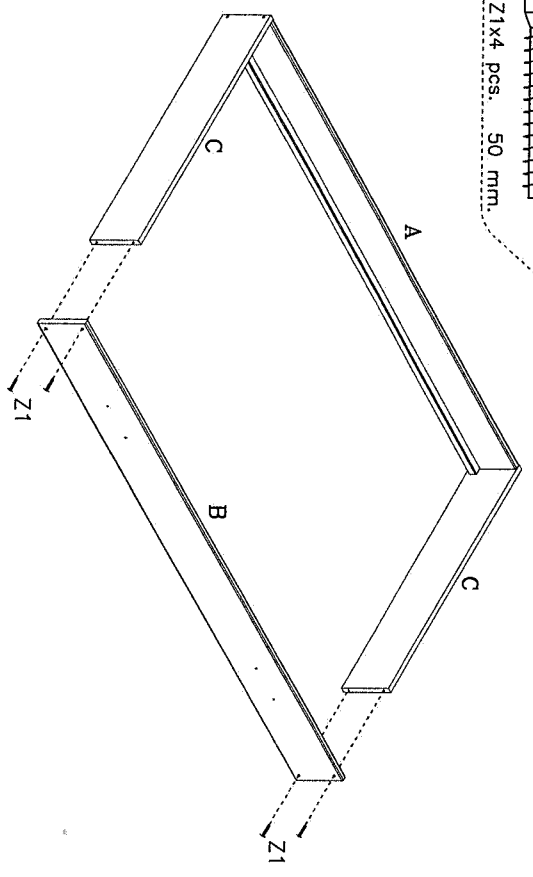
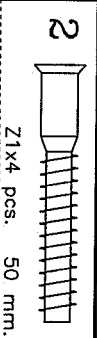
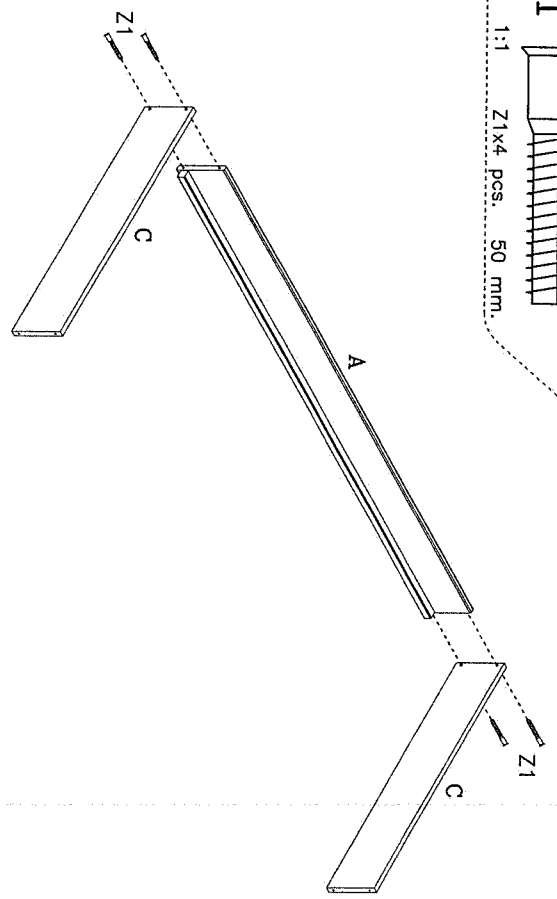
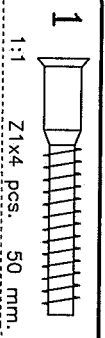

5



Z4x2 pcs. 40 mm.

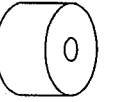

Z7x2 pcs.

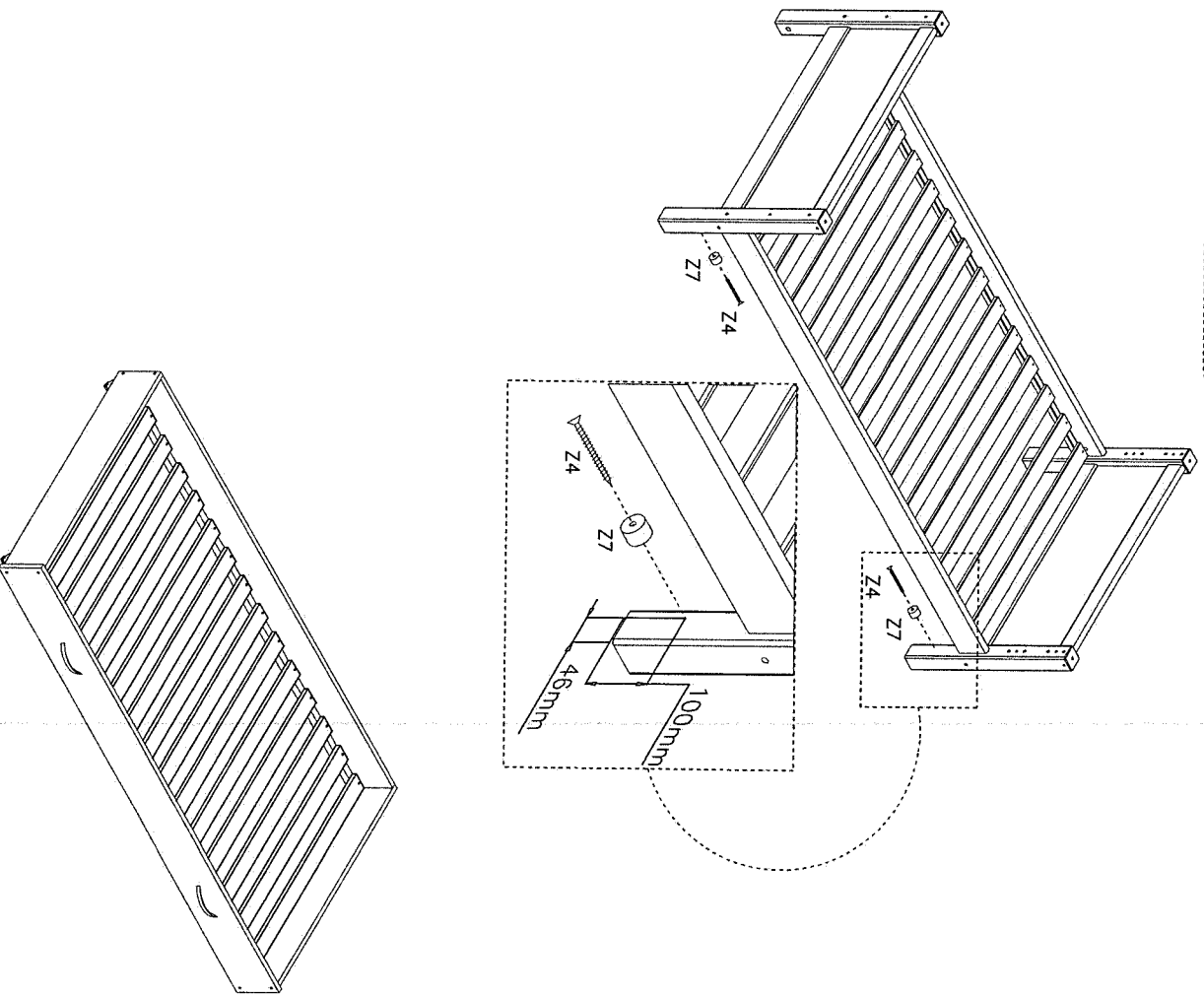

6



Z3x30 pcs. 30 mm.

