

Art. Nr. 3459 3843, 9042 3910

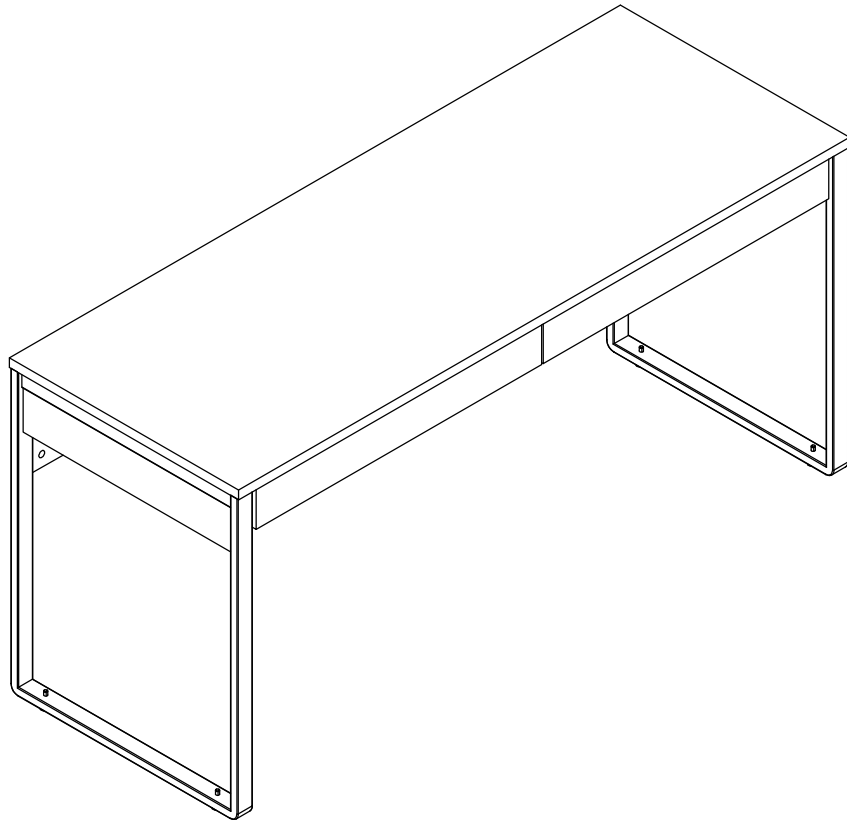

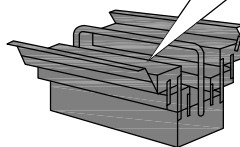

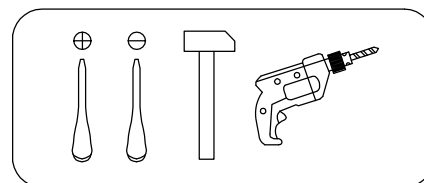

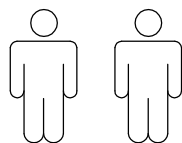







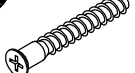



LKZ 41164



- | | |
|---------------------------------------|-----------------------------------|
| D Montageanleitung | GB Assembly instructions |
| FR Notice de montage | IT Istruzioni di montaggio |
| NL Handleiding voor de montage | PL Instrukcja montazu |
| CZ Montážní návod | SK Návod na montáž |
| HU Szerelési útmutató | RO Instrukțiuni de montaj |
| TR Montaj talimati | RU Инструкция по монтажу |



0
10
20
30
40
50
60
70
80
90
100

A 090913  7x32 x28	B 081320  x8	C 000146  15x12 x32	D 090912  15x10 x4	E 101608  7x50 x8	F 168849  L350 x2
G 235593  6x8 x8	H 000767  3x13 x12	I 208693  M6x16 x4	J 135021  x12	K 000759  3x20 x12	L 000083  M6x12 x7
M 007460  M6x16 x4	N 230041  22x16 x4	O 155999  x2	P 000754  3.5x16 x4	Q 013859  8x40 x2	R 090185  4.5x45 x2

N	Size/MaB (mm)	Qty	✓	N	Size/MaB (mm)	Qty	✓
1	1600x600x22	1		9	748x90x16	1	
2	552x100x16	1		10	672x75x12	2	
3	552x100x16	1		11	350x75x12	2	
4	360x90x16	2		12	350x75x12	2	
5	360x90x16	1		13	682x347x3	2	
6	1540x139x16	1		14	735x595x105	1	
7	1516x248x16	1		15	735x595x105	1	
8	748x90x16	1		16	1530x25x25	1	

Service - Dienstverlening - Serwis - Servis - Сервисная служба

Name - Naam - Nazwa - Isim - Название

Nr. - No. - Номер

Typ - Type - Тип - Тип

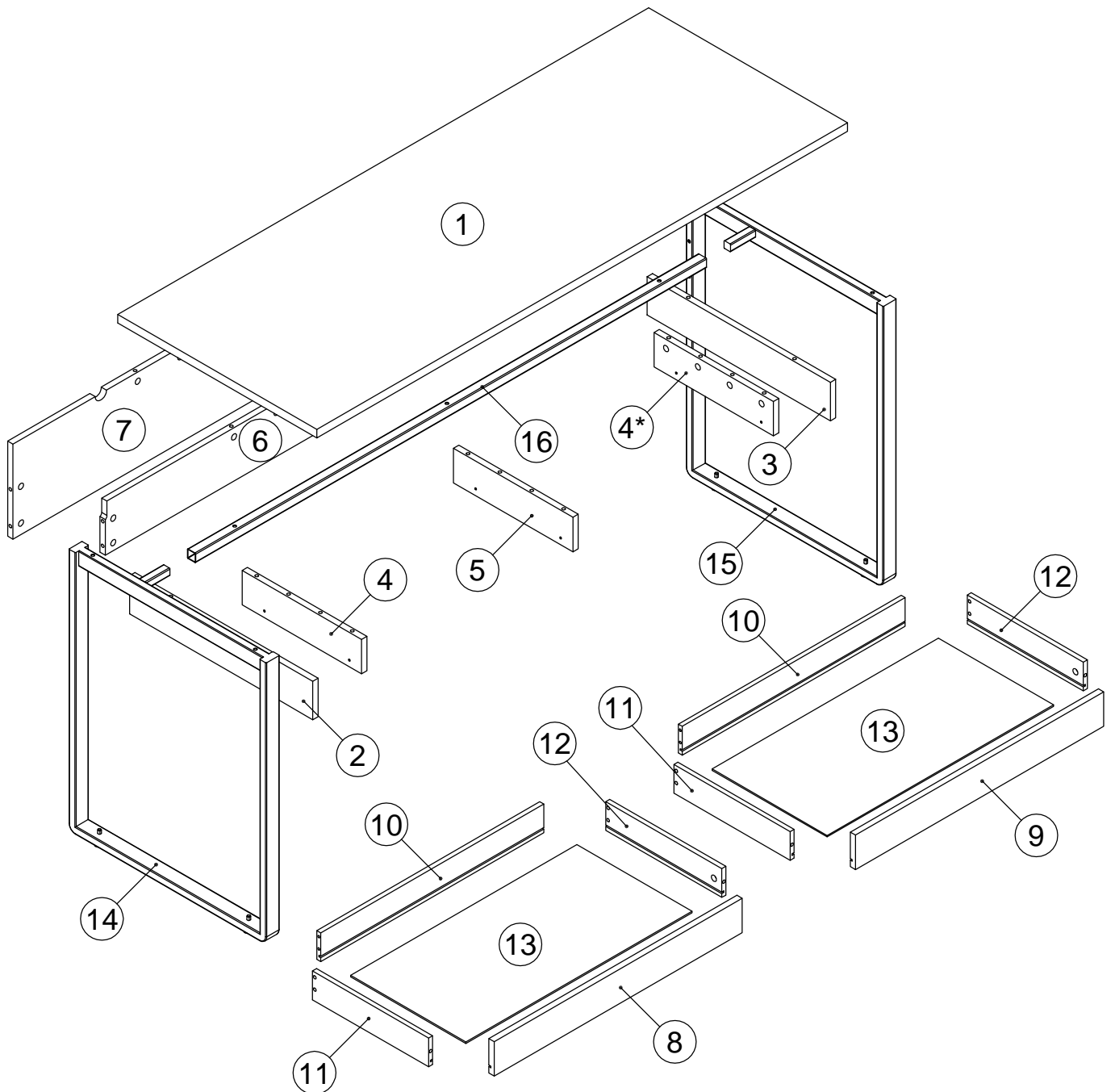
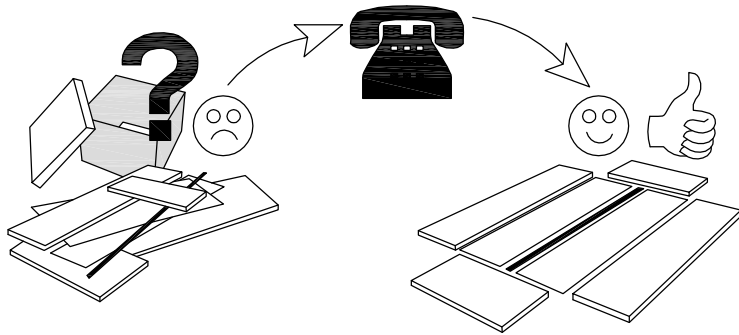
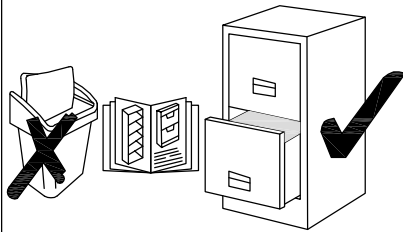

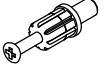

1

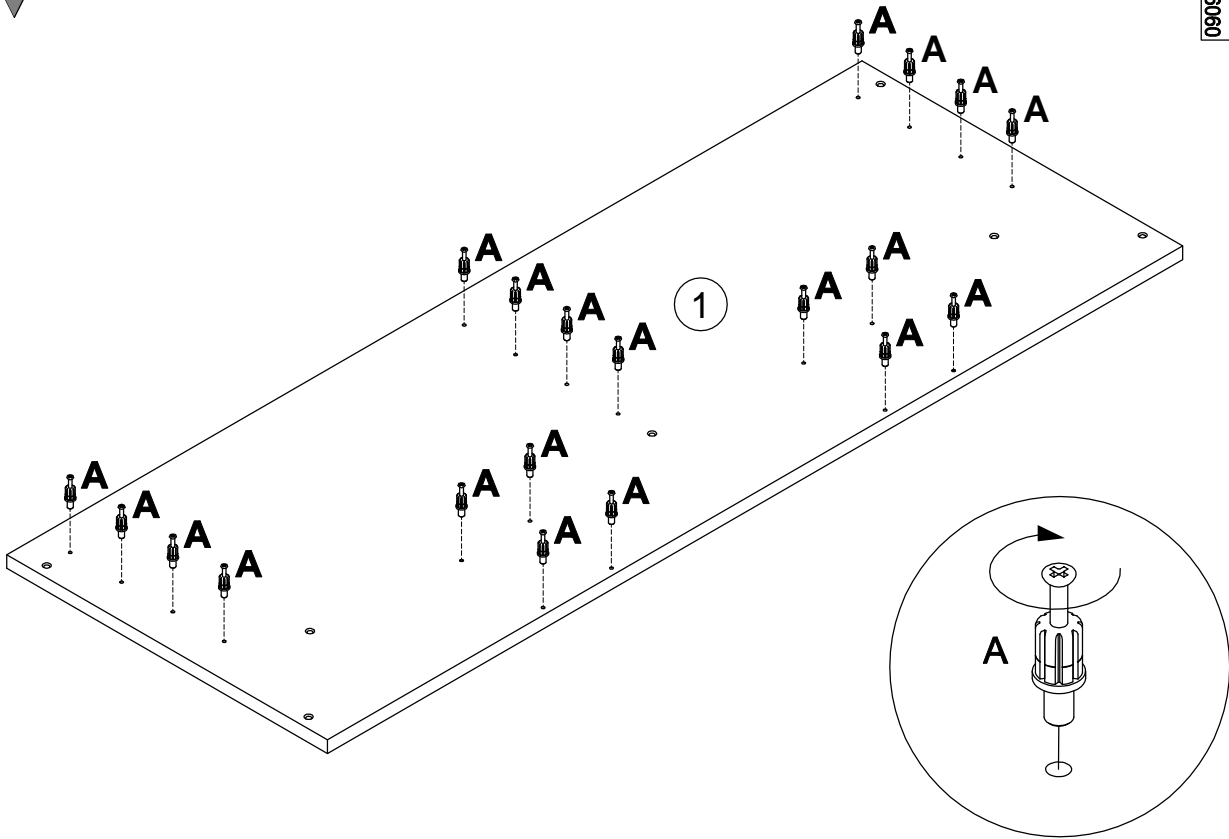
A	7x32
090913	
	x20



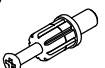

2

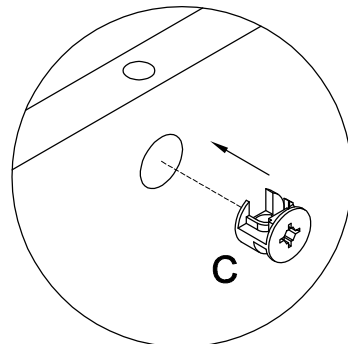
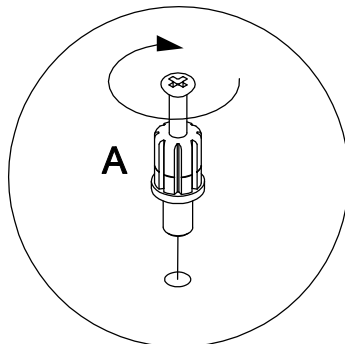
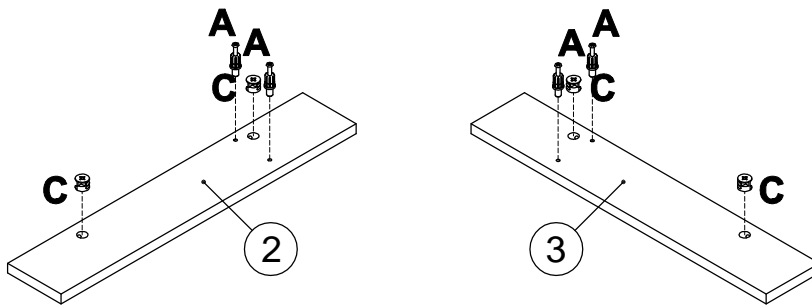
A	7x32
090913	
	x4
C	15x12
000146	
	x4

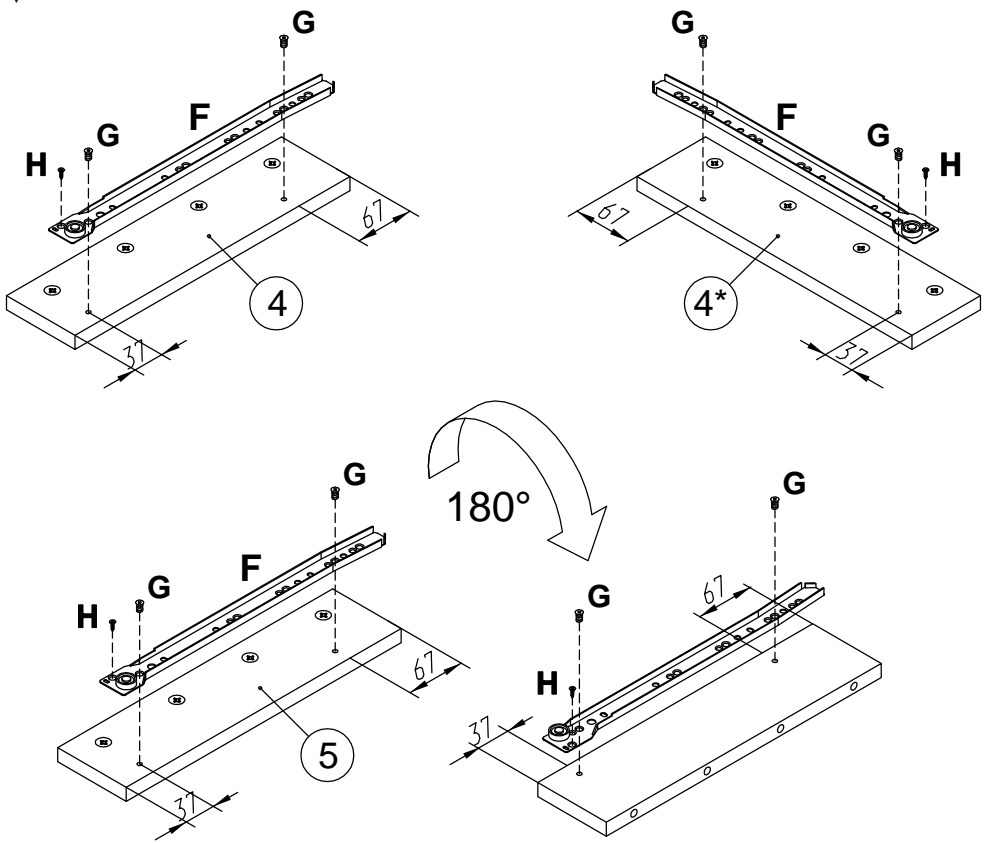
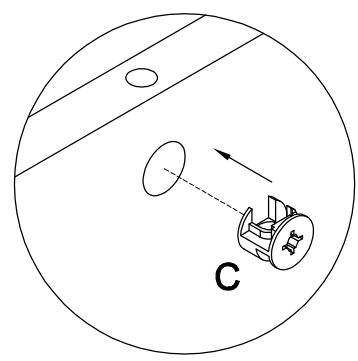
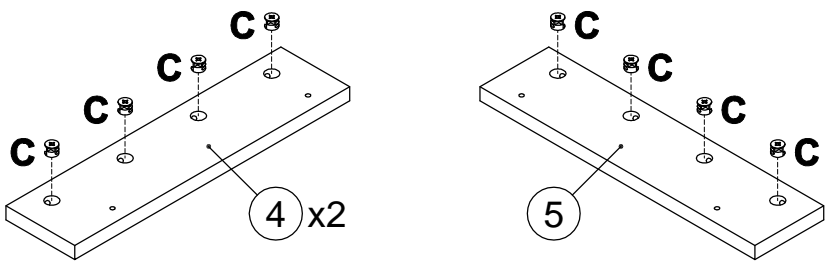



F		L350
168849		x2
G		6x8
235593		x8
H		3x13
000767		x4

5

000146 C



15x12

x8

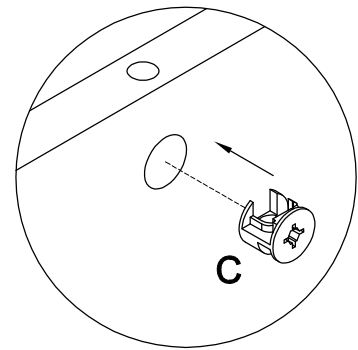
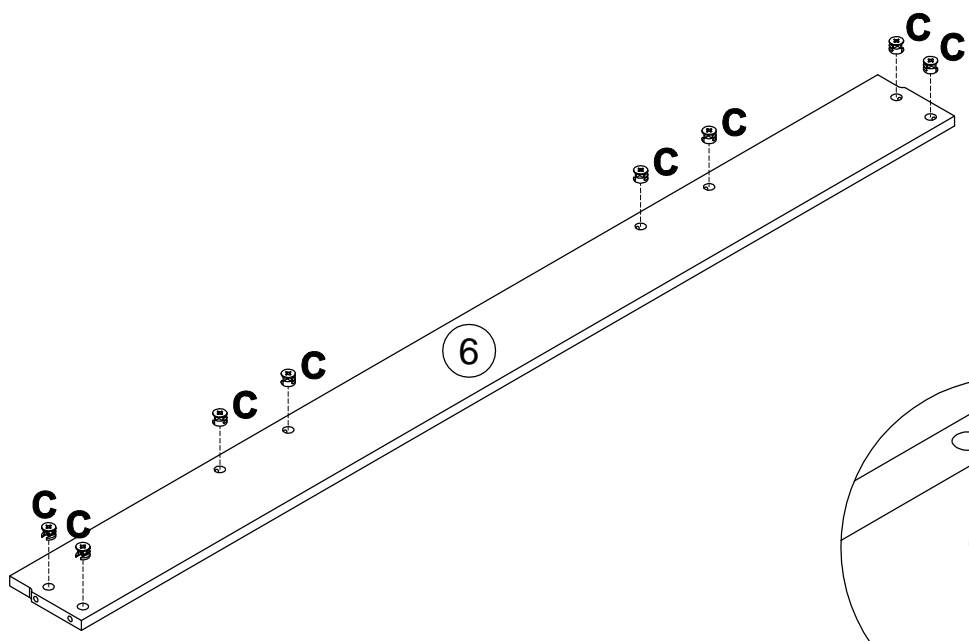

6

000146 C



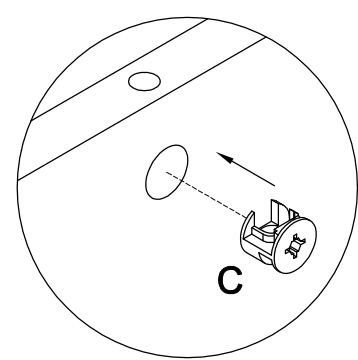
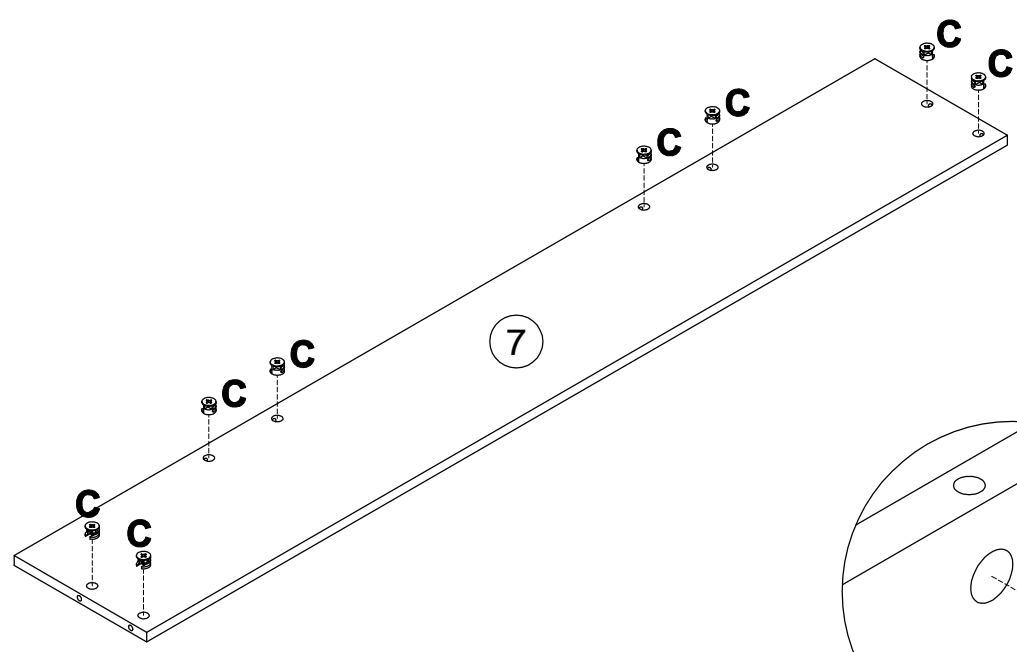

15x12

x8

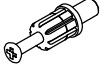

6

7
x2

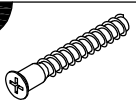
A	090913	7x32		x4
D	090912	15x10		x4
E	101608	7x50		x8

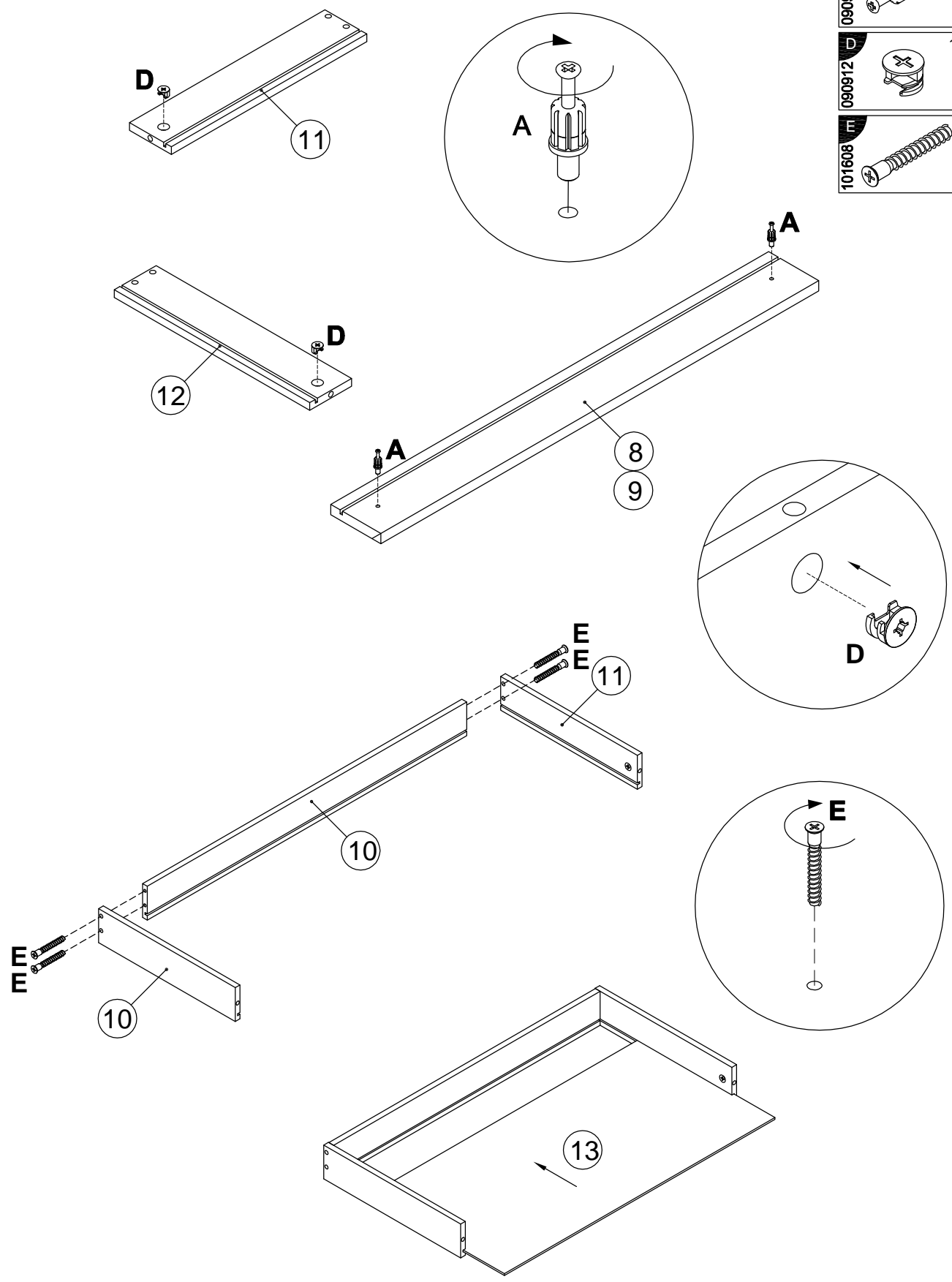

8

x2

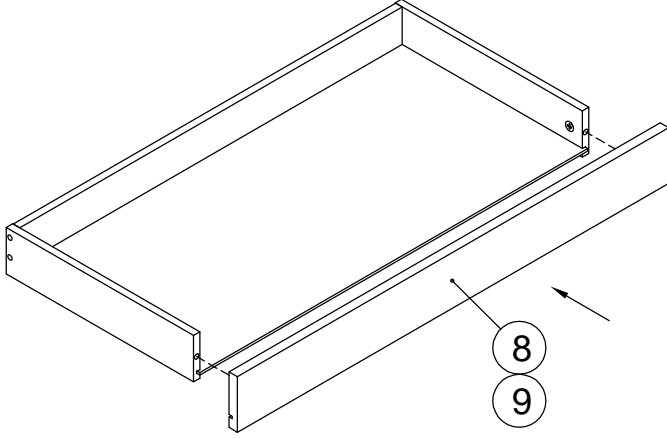

F		L350
168849		x2
H		3x13
000767		x8
J		
135021		x12
K		3x20
000759		x12

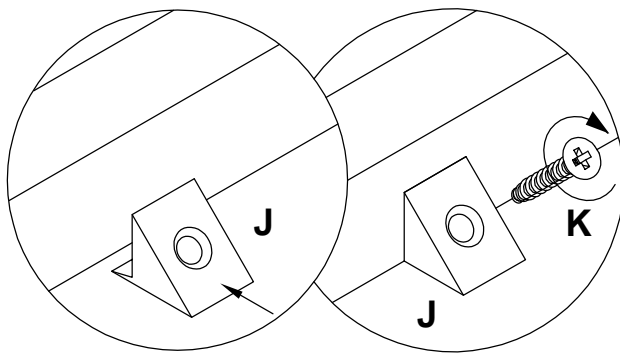
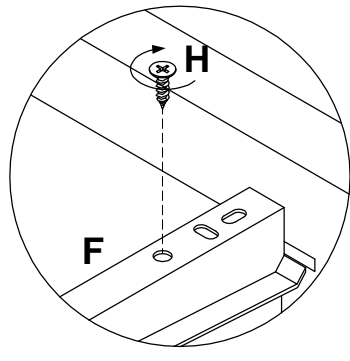
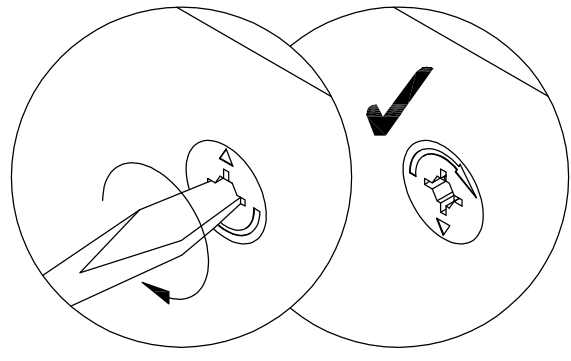
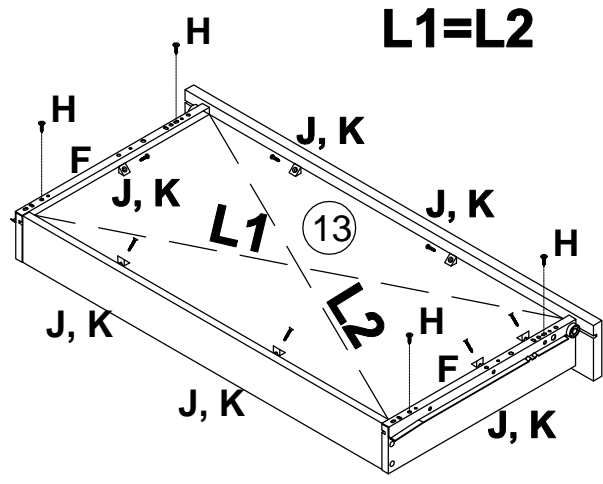

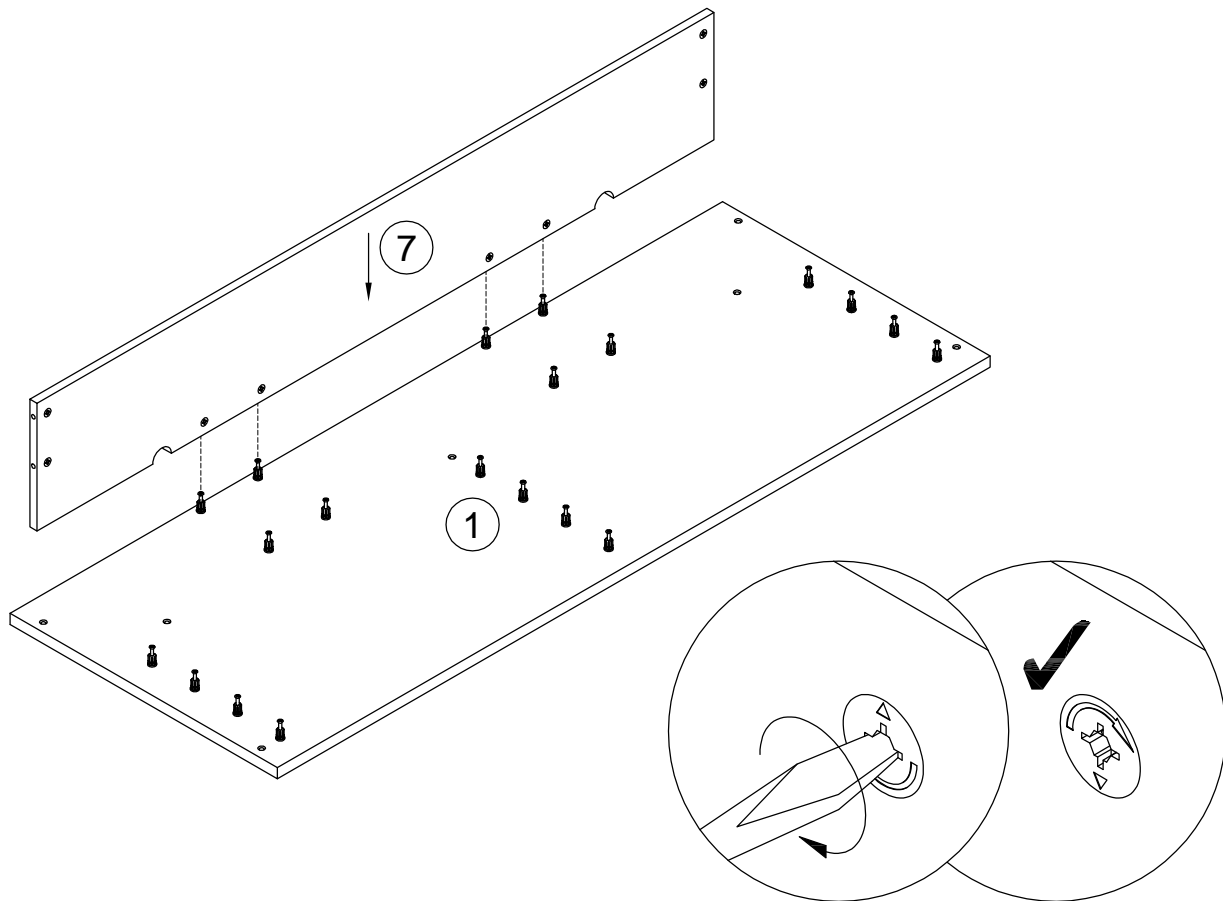

9

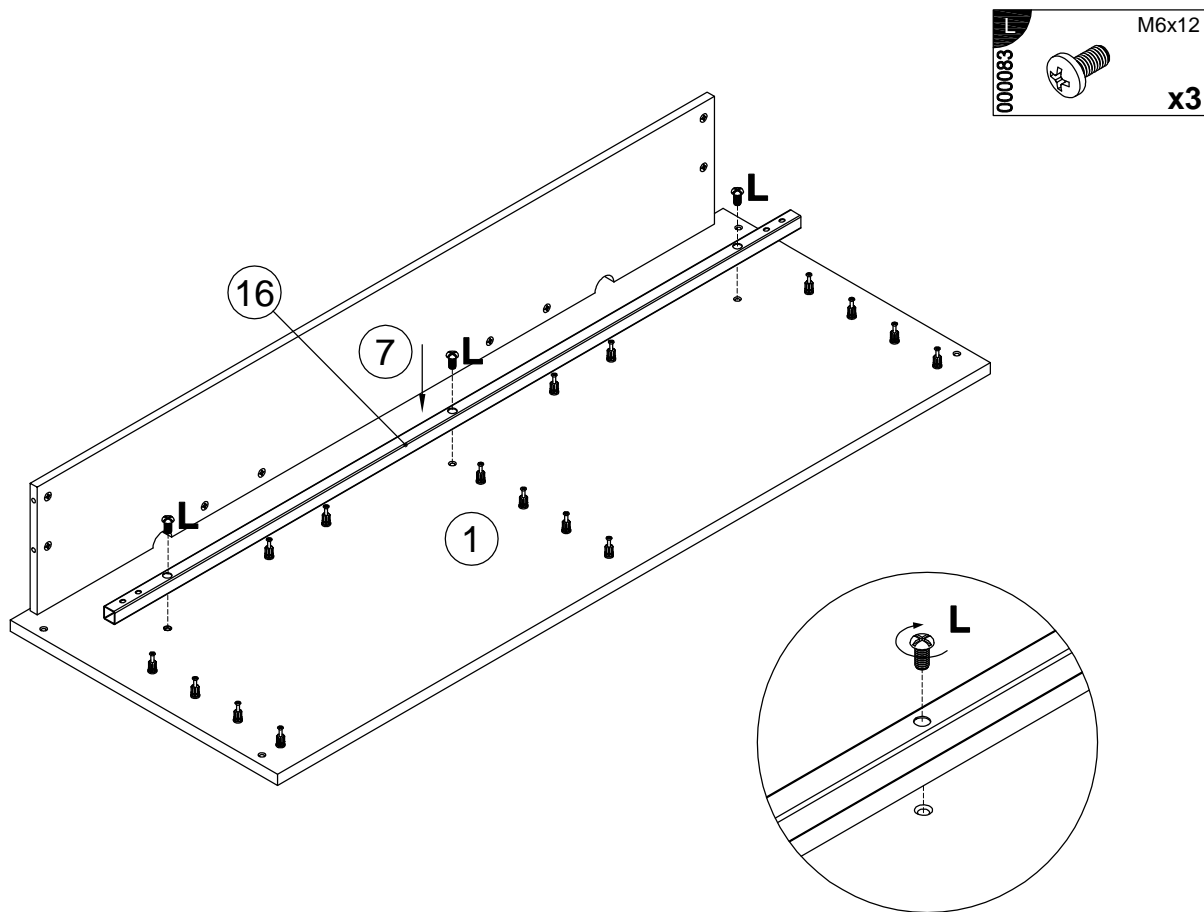

10

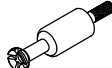

B		x8
I	M6x16 	x4
N	22x16 	x4

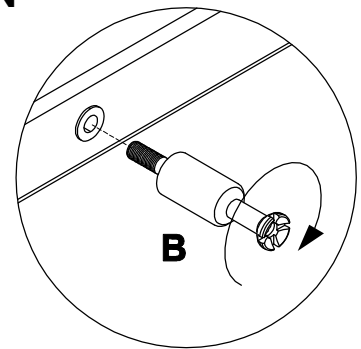
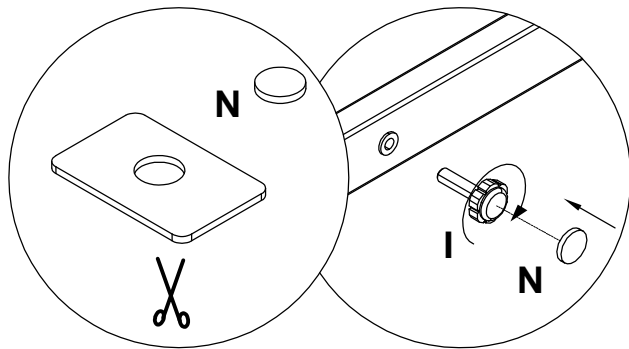
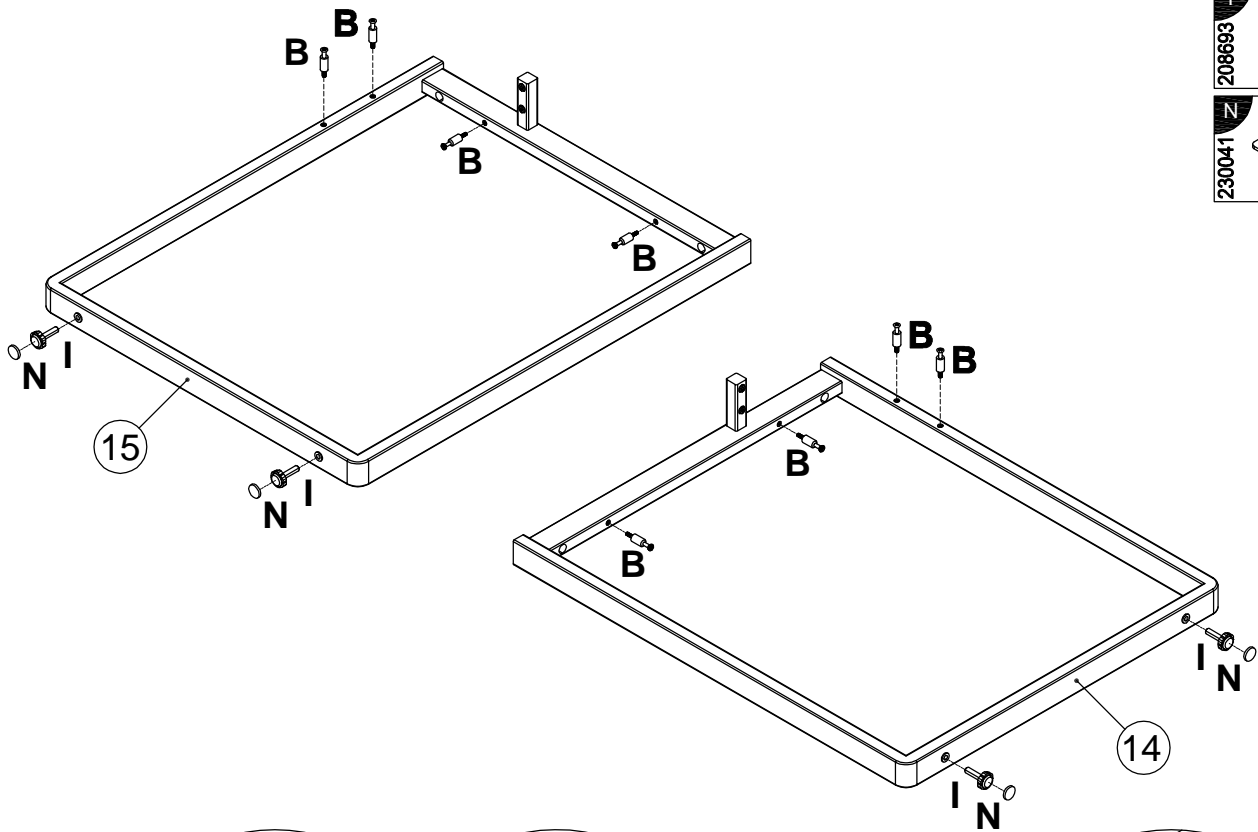

12

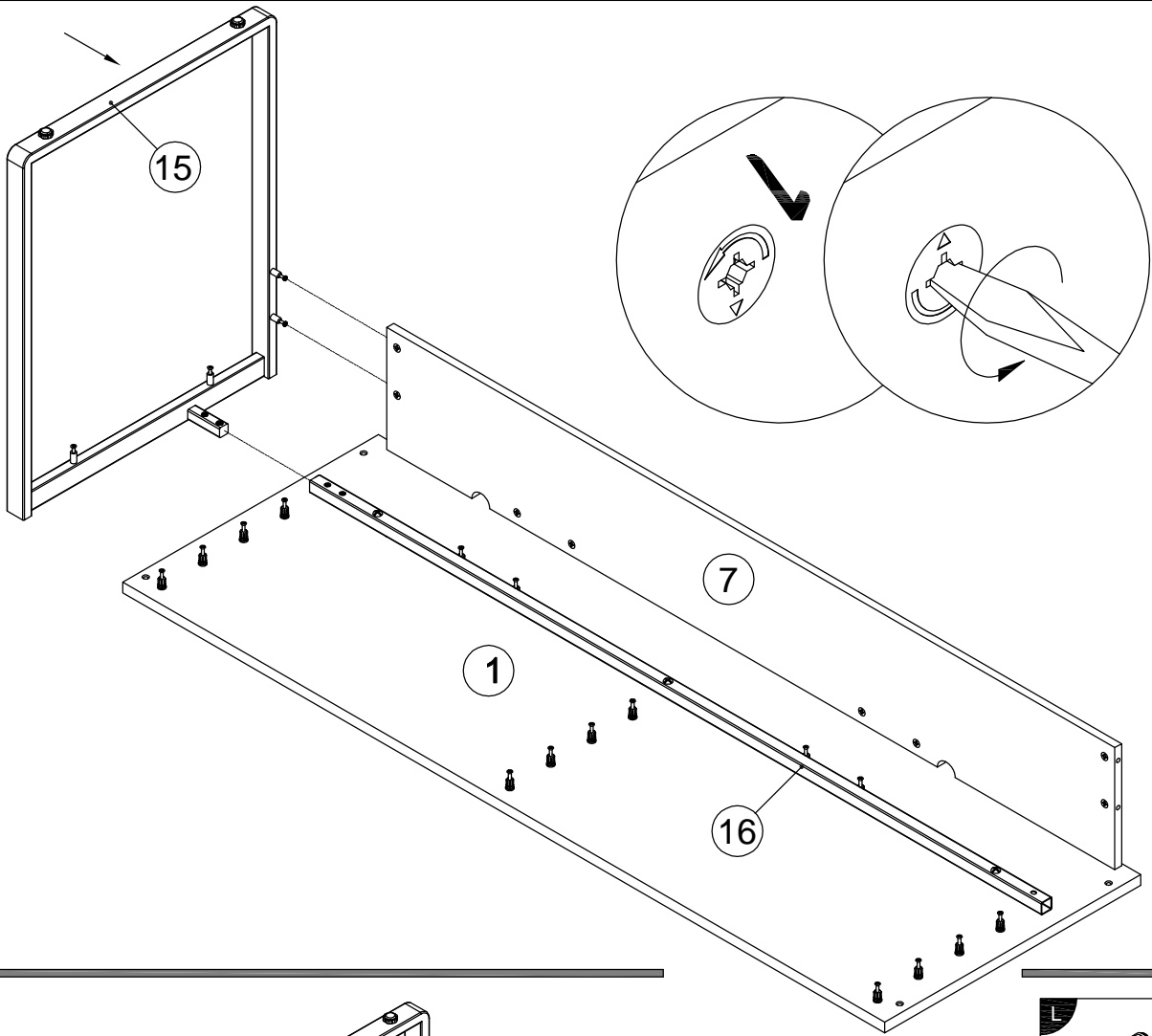

13

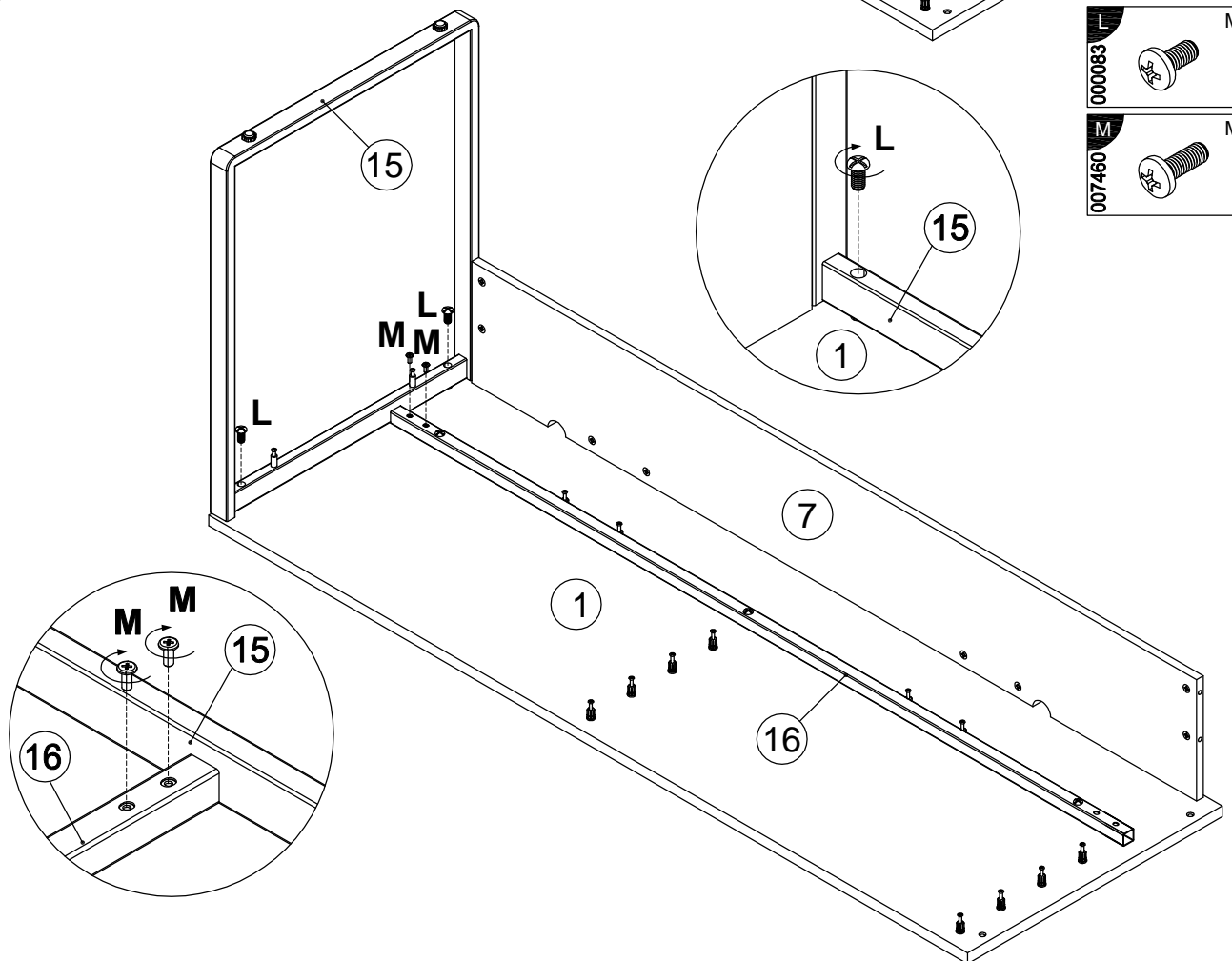

14

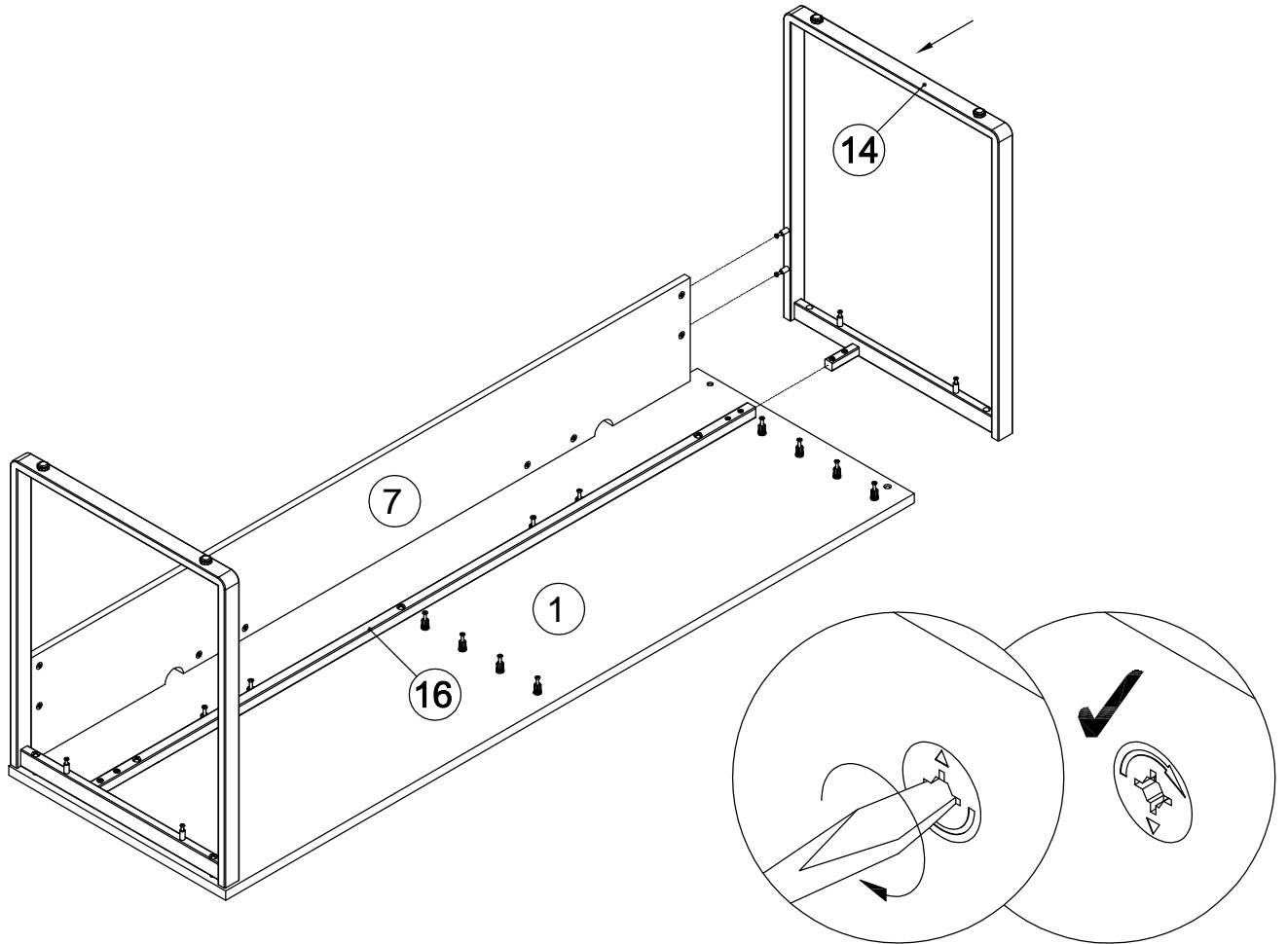

15

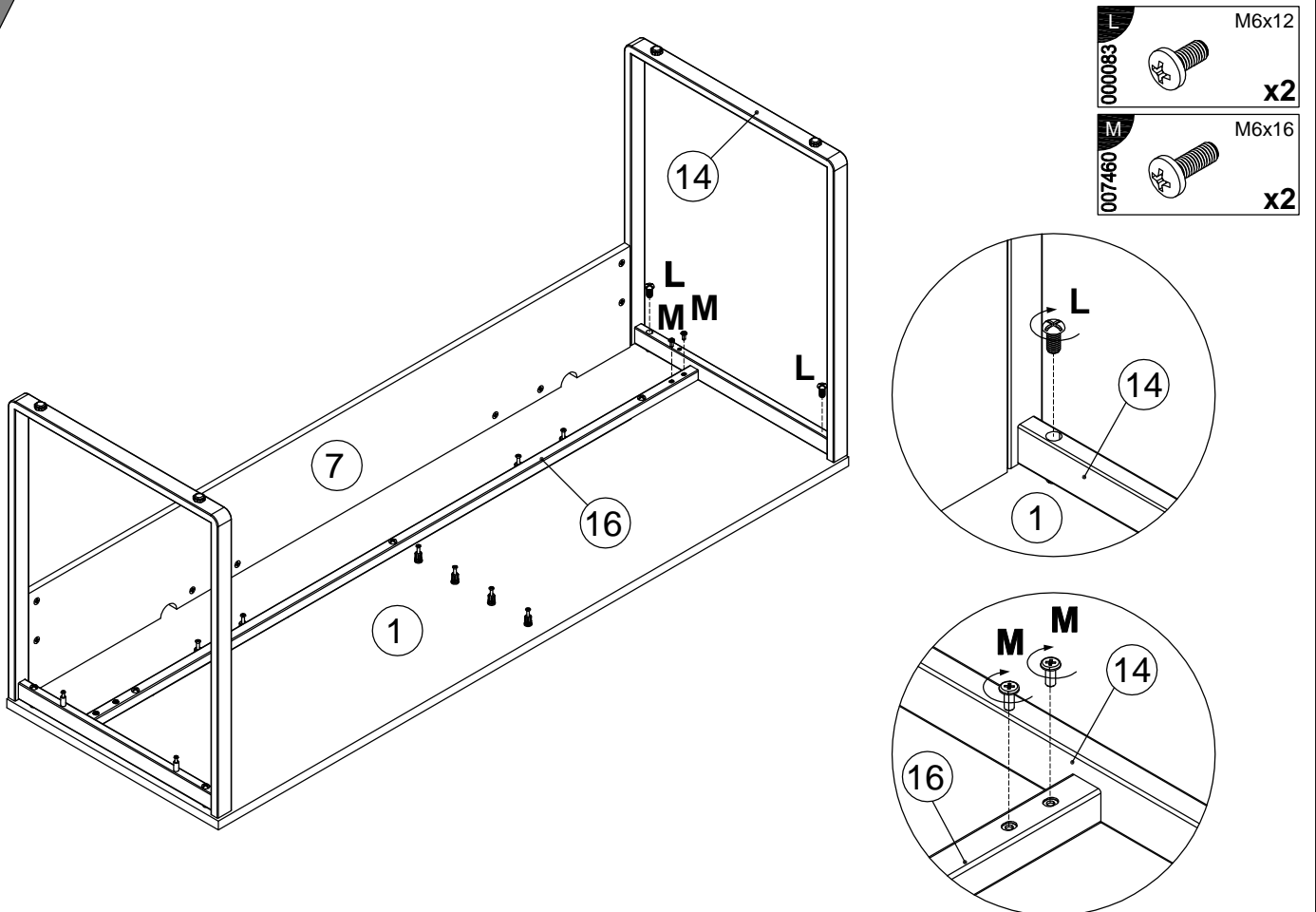

16

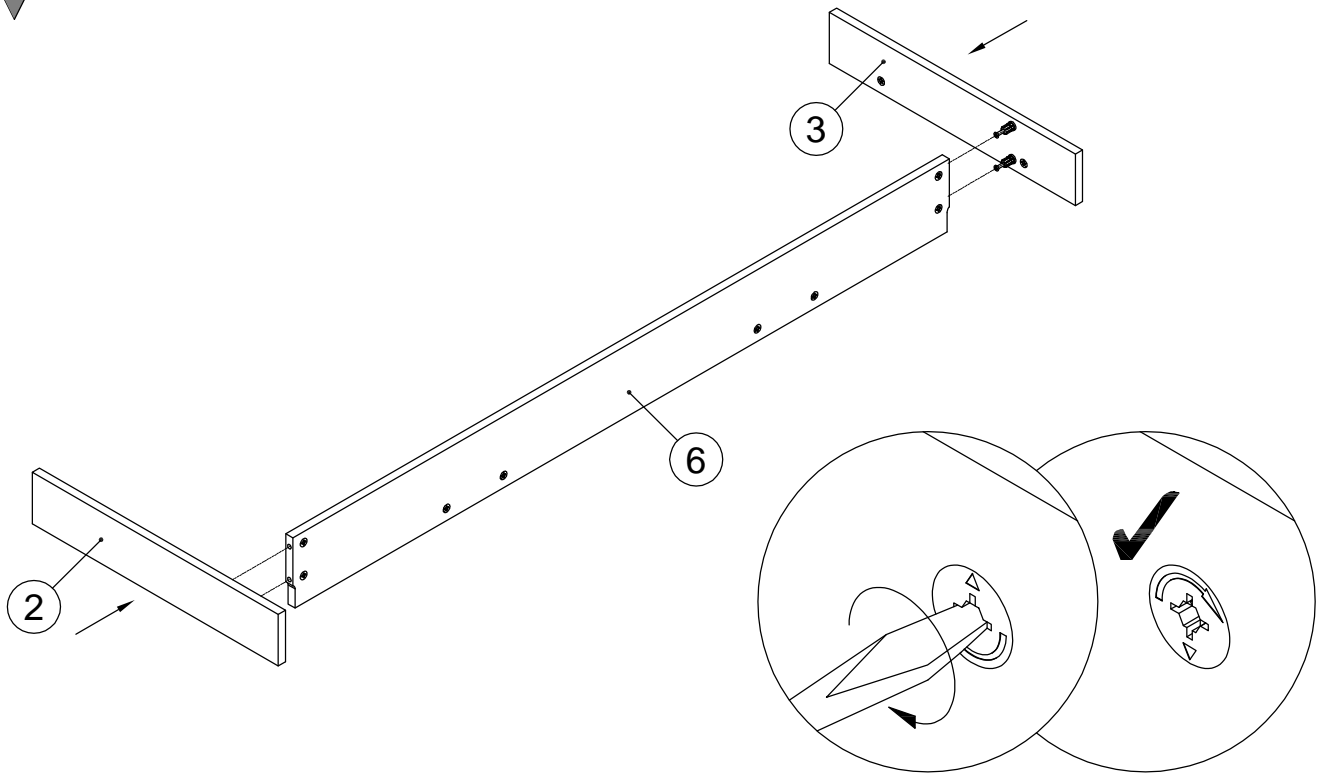

17

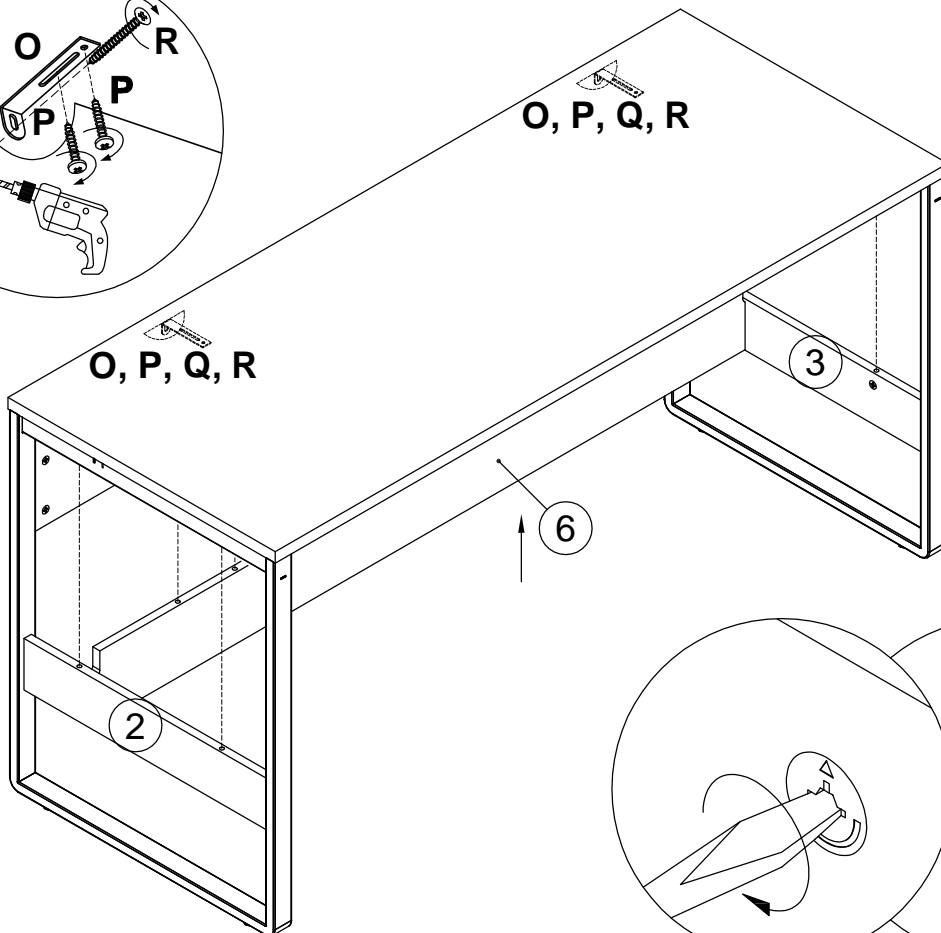
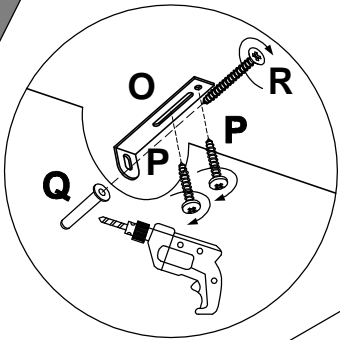

O	155999		x2
P	000754	3.5x16	x4
Q	013859	8x40	x2
R	090185	4.5x45	x2

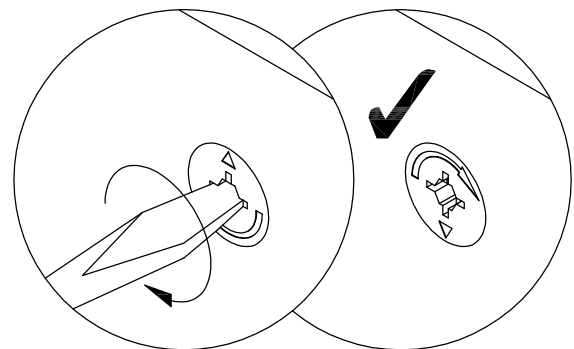

18

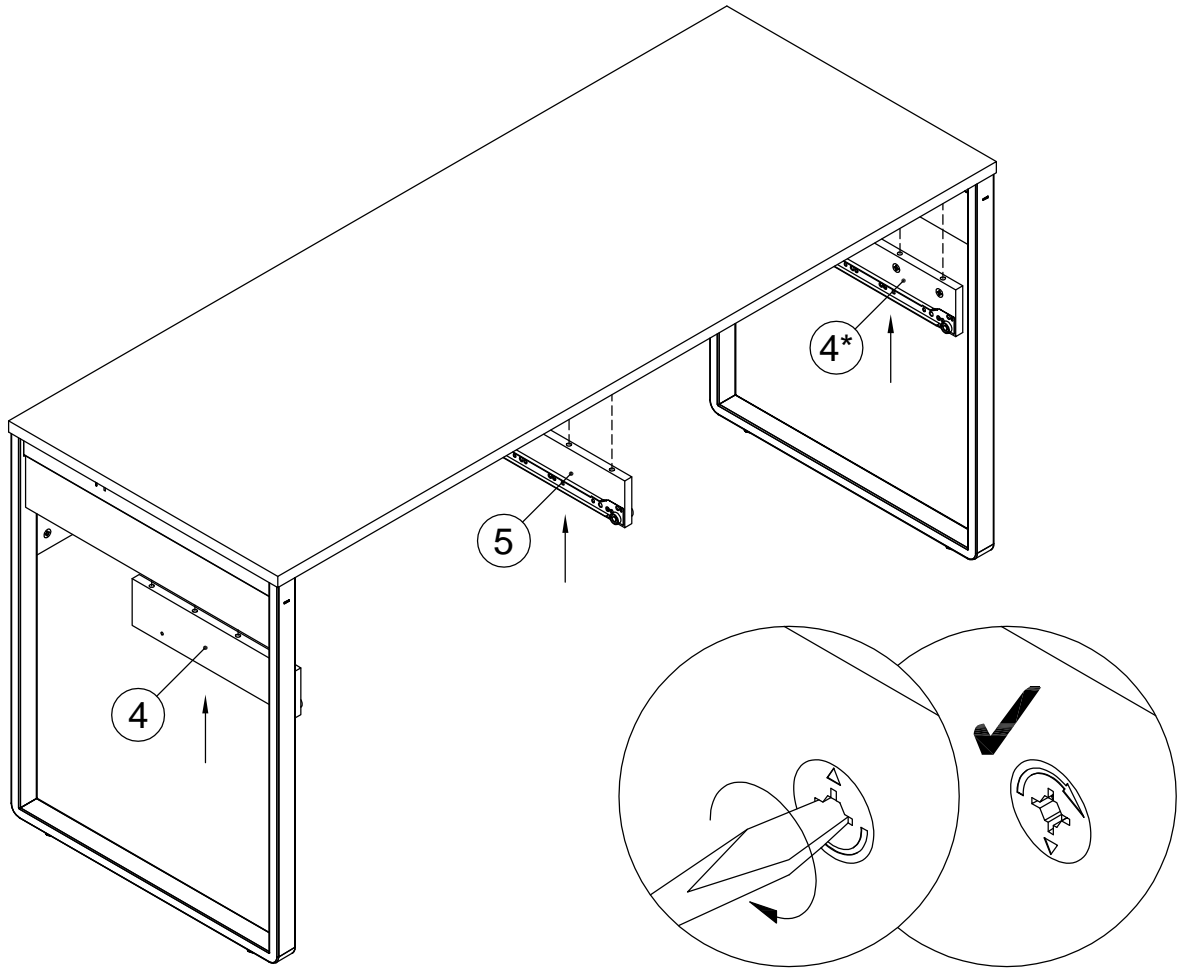

19

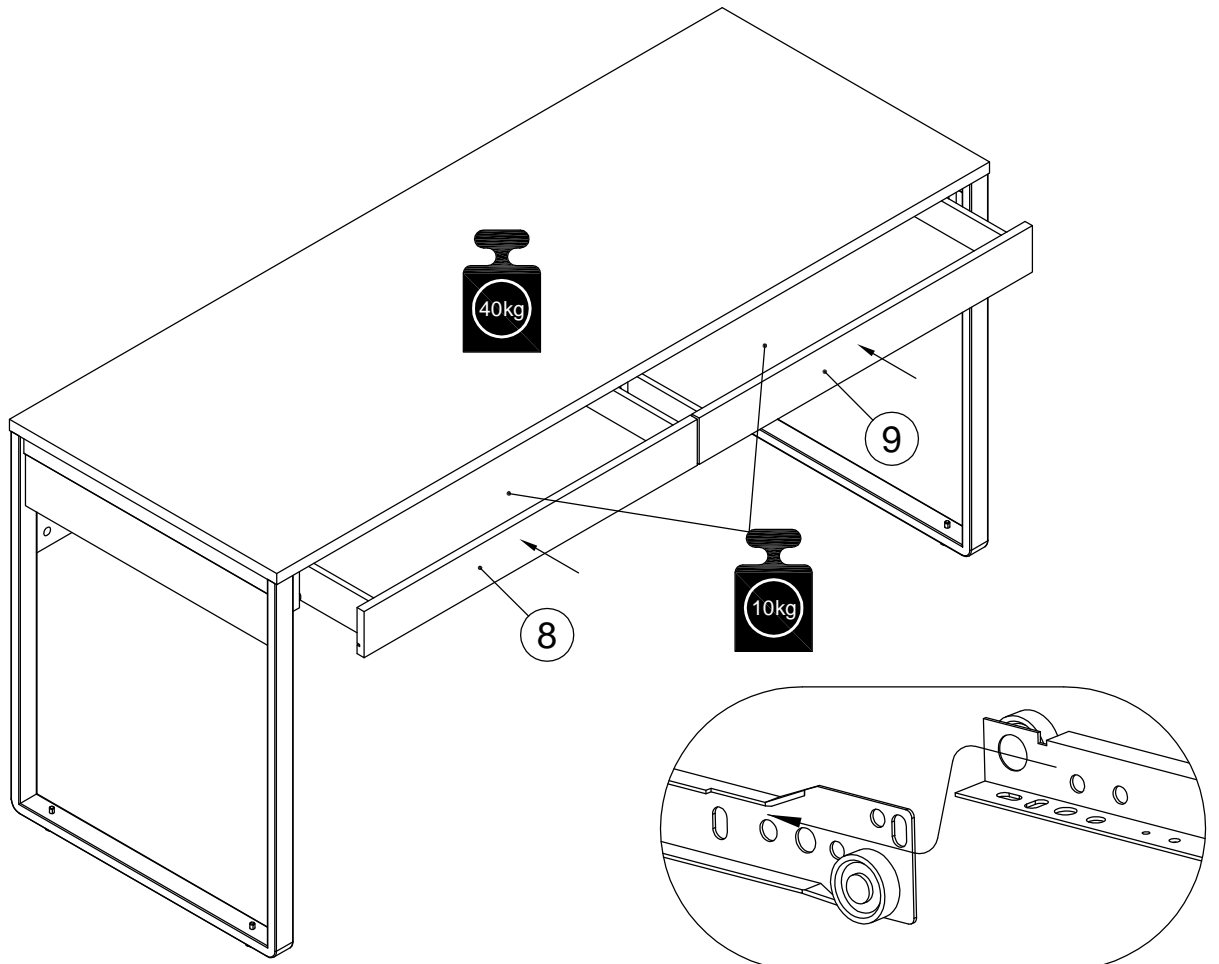

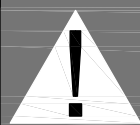

Achtung • Attention • Attenzione
Opgelet • Uwaga • Pozor • Figyelem
Atenție • Dikkat • Внимание

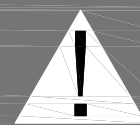

(D)	Wandbefestigung dient als Kippschutz – unbedingt anbringen! Bei einigen Wandtypen kann ein Spezialdübel erforderlich sein!
(GB)	The wall fastening serves to prevent tipping – be absolutely sure to mount it! For certain wall types, a special wall plug may be necessary!
(FR)	La fixation murale sert de protection contre le basculement – à installer impérativement ! Pour certains types de murs il faut des chevilles spéciales !
(IT)	Il fissaggio alla parete serve da protezione anti-ribaltamento – attaccarla assolutamente ! Per alcune strutture di parete può essere necessario un tassello speciale !
(NL)	Bevestiging aan de muur dient als kantelbescherming – zeker en vast bevestigen ! Bij enkele muurtypen is een speciale plug misschien vereist !
(PL)	Mocowanie do ściany jest jednocześnie zabezpieczeniem przed przewróceniem – koniecznie zamontować! Do niektórych rodzajów ścian koniecznie zastosować specjalne kołki mocujące.
(CZ)	Montáž na stěnu slouží jako ochrana proti převrnutí – bezpodmienečně umístěte! Uněkterých typů stěn může být zapotřebí speciální hmoždinka !
(SK)	Upevnenie na stenu slúži ako ochrana proti prevráteniu – bezpodmienečne použite! Pre niektoré druhy stien môže byť potrebná špeciálna hmoždenka!
(HU)	A terméket a falhoz kel rögzíteni, különben az felborulhat! Egyes faltípusoknál speciális tiplit kell használni !
(RO)	Sistemul de fixare la perete serve ște ca protecție la răsturnare – de montat obligatoriu! Pentru unele tipuri de pereți este posibil să fie necesar un diblu special !
(TR)	Duvardaki sabitleme, devrilmeye karşı bir emniyet tedbiridir ve mutlaka monte edilmelidir! Bazı duvar tiplerinde bunun için özel bir dübel gereklidir !
(RU)	Обязательно установите крепление на стене во избежание опрокидывания ! Для некоторых типов стен может потребоваться специальный дюбель !